



SANYO HVAC (Division of SANYO Commercial Solutions)

Think GAIA  
For Life and the Earth



SANYO HVAC is recognized as a world leader in split-air conditioning technology. Our focus on efficiency and reliability demonstrates our commitment to our customers and our planet.

**ECOi Technical  
Tips**

## Refrigerant Properties

Higher Pressure (R410A is 1.6 times higher than R22.)

Compressor oil is different.

R410A uses Polyol Esther Oil (Synthetic fluid)

Different Gauge-manifold, Charge hose, etc., must be used for R410A.

Near-Azeotrope Type Refrigerant

Only charge the refrigerant in **liquid form**.

# U Series

## Increasing fan Speed

If External static pressure is too great (due to long extension of ducts, for example), the air flow volume may drop too low at each air outlet. This problem may be solved by increasing the fan speed using the following procedure:

1. Remove 4 screws on the electrical component box and remove the cover plate.
2. Disconnect the fan motor sockets in the box.
3. Securely connect the booster cable sockets between the disconnected fan motor sockets as shown below.
4. Place the cable neatly in the box and re-install the cover plate.

### **3-5. Increasing the Fan Speed**

If external static pressure is too great (due to long extension of ducts, for example), the air flow volume may drop too low at each air outlet. This problem may be solved by increasing the fan speed using the following procedure:

- (1) Remove 4 screws on the electrical component box and remove the cover plate.
- (2) Disconnect the fan motor sockets in the box.
- (3) Take out the booster cable (sockets at both ends) clamped in the box.
- (4) Securely connect the booster cable sockets between the disconnected fan motor sockets in step 2 as shown in Fig. 3-15.
- (5) Place the cable neatly in the box and reinstall the cover plate.

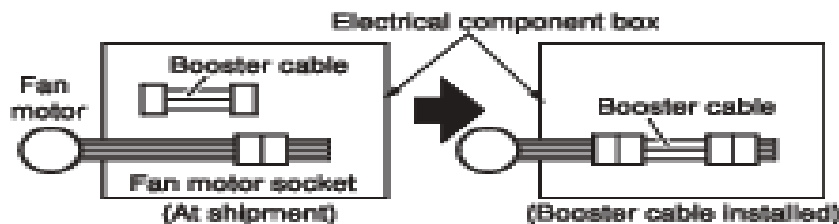

## Indoor Unit Power Requirements

All Eco-I indoor units require a 208/230 VAC single phase power supply. Each indoor unit should be supplied with a field supplied disconnect switch.

Ex: Typical Wiring Connections at Indoor Unit

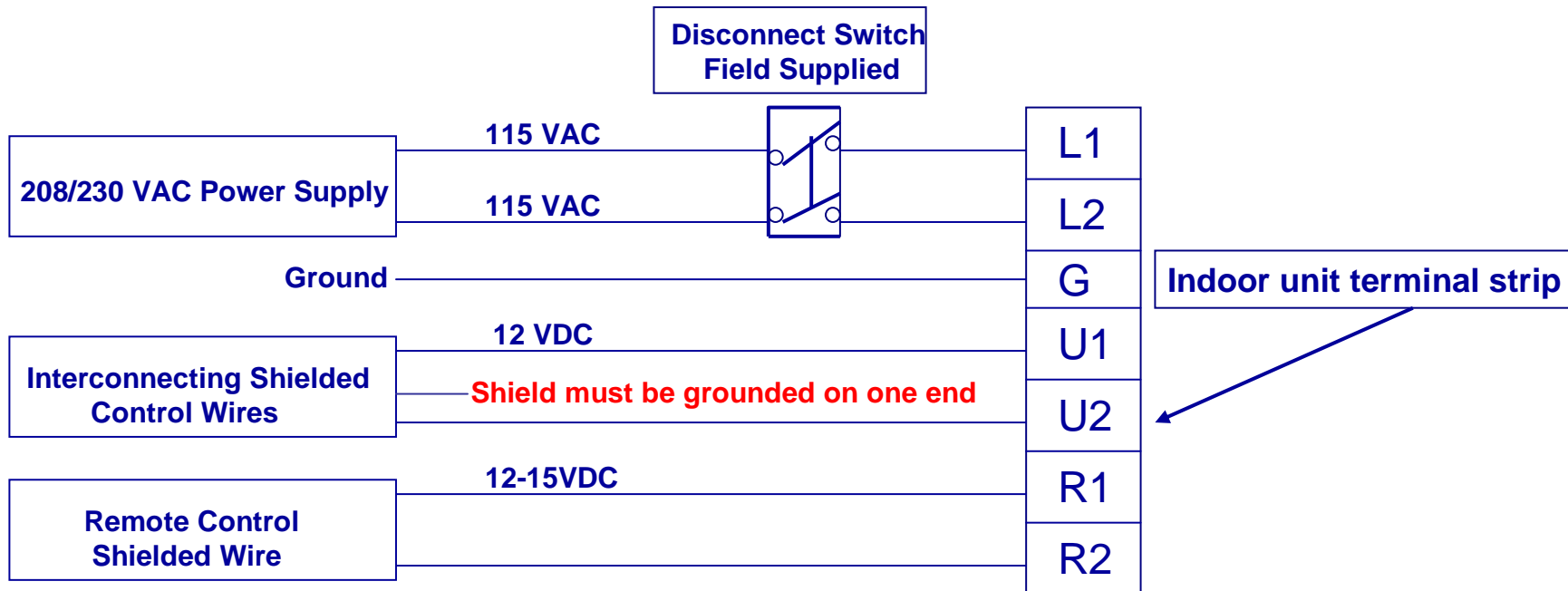

1. Measure the voltage of each phase to ground. For example:
  - a. L1 to Ground = 123 Volts
  - b. L2 to Ground = 217 Volts (this would be the wild leg)
  - c. L3 to Ground = 123 Volts
2. Measure phase to phase to insure acceptable voltages. For example:
  - a. L1 to L2 = 249 Volts
  - b. L1 to L3 = 249 Volts
  - c. L2 to L3 = 249 Volts

### Corrective Actions:

1. Connect the "wild leg" to the "L3" (or "T") power supply terminal of the outdoor unit. Connect the other two phases to L1 and L2.
2. Reapply power to the outdoor unit.
3. If the system still fails to operate or to allow initiation of the Auto Address function a "reverse phase" may be causing the problem. If so, turn power off and reverse the wires attached to L1 and L2.
  - a. Note: Reverse phase may also be indicated by the fault code "P05".

For additional details please access our technical literature using our website at [www.sanyohvac.com](http://www.sanyohvac.com) or contact our technical service department at 800-851-1235.

A good communication line should read around 100 ohm's at both the indoor and outdoor unit.

Indoor unit at U1 & U2 communication line



Outdoor unit at U1 & U2 communication line



# Power Requirements for Mini-Eco-I 3 & 5 Ton

## 5-2. Recommended Wire Length and Wire Diameter for Power Supply System

### Outdoor unit

Type	(A) Power supply wiring	Time delay fuse or circuit capacity
CHX03652	For field wiring rules, please refer to your LOCAL ELECTRICAL CODES	30 A
CHX06052		50 A

### Indoor unit

Type	(B) Power supply wiring	Time delay fuse or circuit capacity
K	For field wiring rules, please refer to your LOCAL ELECTRICAL CODES	15 A
A, X, T, U		15 A
D		15 A

### Control wiring

(C) Inter-unit (between outdoor and indoor units) control wiring	(D) Remote control wiring	(E) Control wiring for group control
AWG #18 (0.75 mm <sup>2</sup> ) Use shielded wiring*	AWG #18 (0.75 mm <sup>2</sup> ) Use shielded wiring	AWG #18 (0.75 mm <sup>2</sup> ) Use shielded wiring
Max. 3,280 ft.	Max. 1,640 ft.	Max. 1,640 ft. (Total)

### NOTE

\* With ring-type wire terminal.

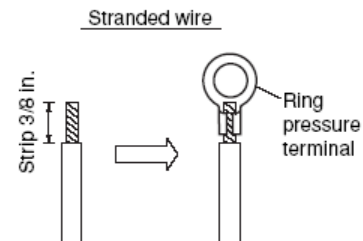

#### E15 alarm

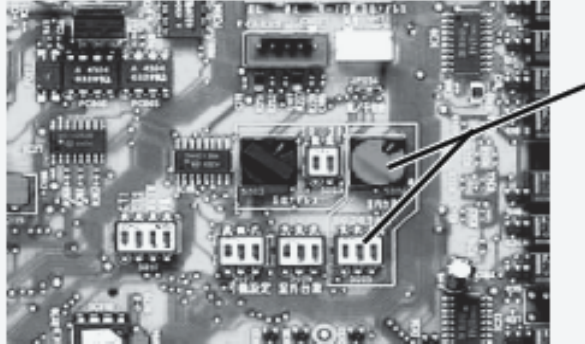
Alarm code	E15
Alarm meaning	Automatic address setting alarm (too few units)
Alarm conditions	The number of indoor units was too few when automatic address setting was performed.
Probable cause	(1) The number of indoor units set at the indoor unit quantity setting SW (S004, S005) on the outdoor unit PCB is too many. (2) The inter-unit control wiring between indoor units has been cut.
Check	(1) Refer to the test run servicing materials and check the indoor unit quantity setting SW (S004, S005). (2) Check the inter-unit control wiring at the indoor and outdoor units.
Correction	After correcting the indoor unit quantity setting or the inter-unit control wiring, perform automatic address setting again.
Example	—
Notes	Super W Multi (INV) switch position 

#### Possible Causes:

- The Dip switches for the number of indoor units is set incorrectly
- One or more of the indoor units is not powered on.
- The U1 & U2 communication is: broken, wired incorrectly, loose terminal connection at one or more of the indoor units terminal block

## Inter-Units control wiring : Not polarity

⇒ ***Do not connect such as star wiring.***

☆ : Star wiring

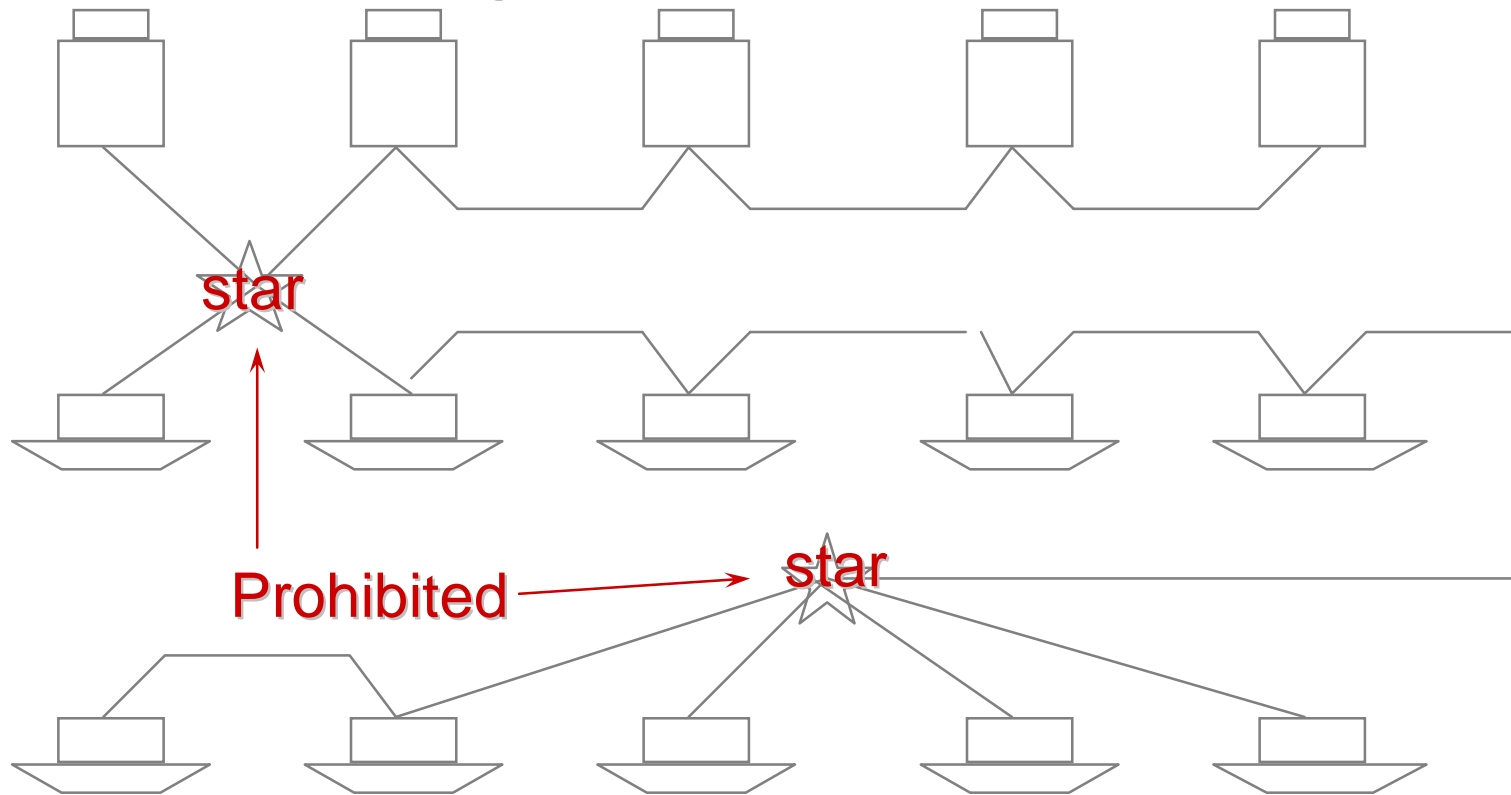

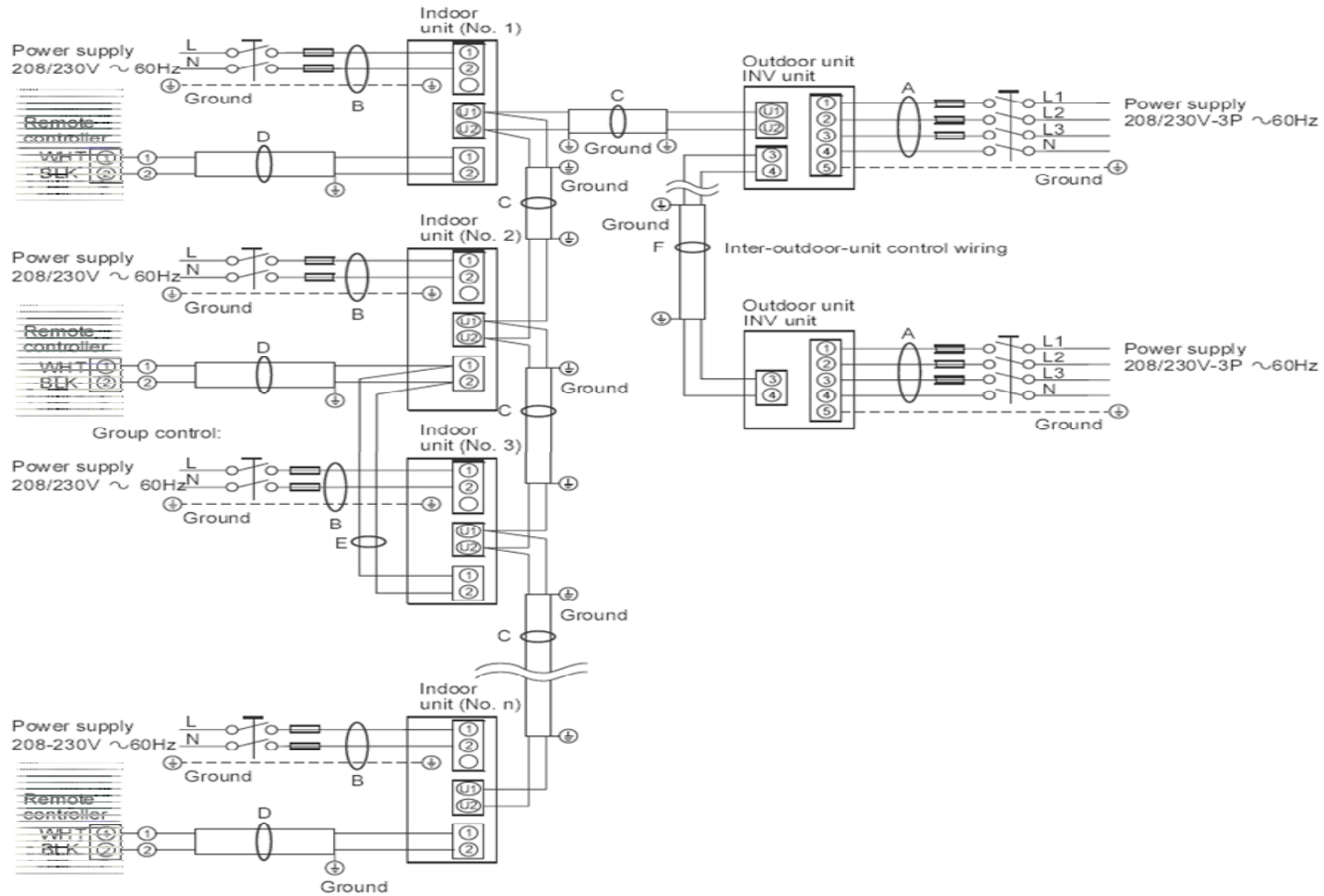

- Change in Shield grounding procedure
- Ground Shield only one end

## Control wiring

(C) Inter-unit (between outdoor and indoor units) control wiring	(D) Remote control wiring	(E) Control wiring for group control
AWG #18 Use shielded wiring*	AWG #18 Use shielded wiring	AWG #18 Use shielded wiring
Max. 3,280 ft.	Max. 1,640 ft.	Max. 1,640 ft (Total)

### NOTE

\* With ring-type wire terminal.

### (F) Inter-outdoor unit control wiring

AWG #18  
Use shielded wiring  
Max. 1,640 ft.

**(5) Use shielded wires for inter-unit control wiring (c) and ground the shield on both sides, otherwise misoperation from noise may occur. (Fig. 4-4) Connect wiring as shown in Section "4-3. Wiring System Diagram."**

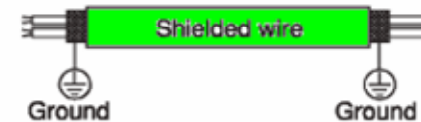

Fig. 4-4



### WARNING

Loose wiring may cause the terminal to overheat or result in unit malfunction. A fire hazard may also exist. Therefore, ensure that all wiring is tightly connected.

When connecting each power wire to the terminal, follow the instructions in "How to connect wiring to the terminal" and fasten the wire securely with the fixing screw of the terminal plate.

- Ground Shield wire only at one end
-

## Heat Sink Paste When replacing a circuit board

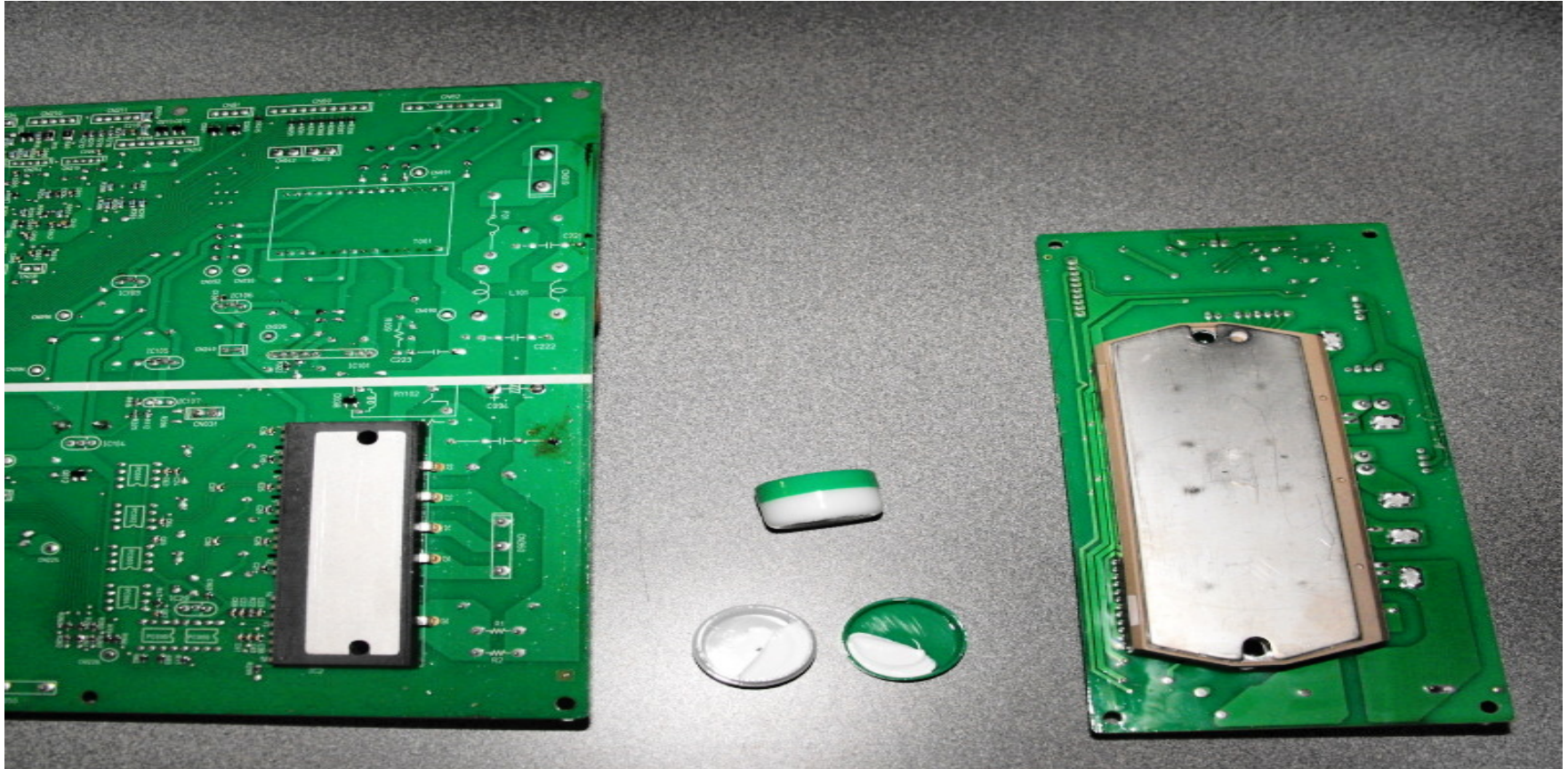

Apply a thin layer of Heat Sink Paste (Supplied) on the HIC and Main PCB boards on the outdoor units

## Installing Distribution Joint

The direction of the distribution joint kit should be horizontal or vertical.

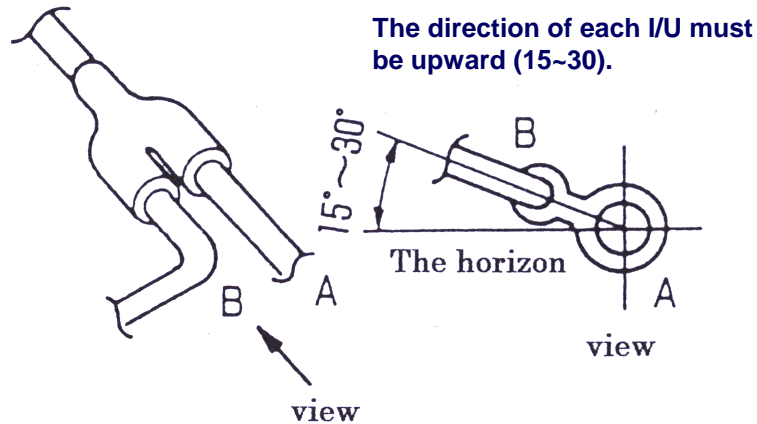

- It is suggested that soft-drawn, ACR grade tubing be used in all cases to minimize equivalent length of tubing run, and leak potential.
- Hard-drawn tubing may be used, if necessary, with long radius elbows.
- 15% silver brazing material is recommended on all solder joints.
- Factory supplied distribution joints (purchased separately) must be used where specified.
- Field installed ball valves, with access ports, are recommended on both branch lines to an indoor unit.

# Maximum Tubing Lengths

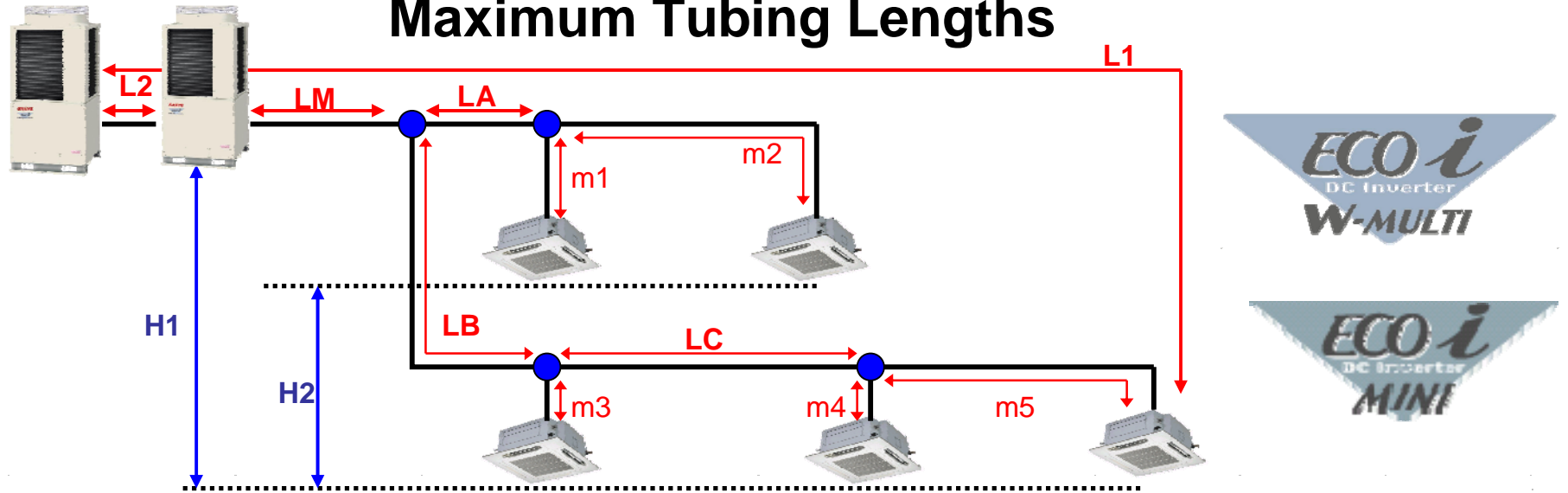

Items	Reference	Contents		Length (feet)	
				Mini Eco-i	W-Multi
Allowable tubing length	L1	Max tubing length	Actual length	≤ 492	≤ 492
			Equivalent length	≤ 574	≤ 574
	m1~m5	Max. length of each distribution joint		≤ 98	≤ 98
	LM	Max. main piping length		≤ 262	≤ 262
	LM+LA+~LC +m1+~m5	Total max. tubing length including length of each distribution joint		≤ 656	≤ 984
Allowable elevation difference	H1	When outdoor unit installed higher		≤ 164	≤ 164
		When outdoor unit installed lower		≤ 131	≤ 131
	H2	Max. difference between indoor units		≤ 50	≤ 50

## Refrigerant Pre-Charge Amount

The refrigerant charge shipped with the condenser from the factory is what is needed for the condenser section only. Once additional piping is installed to the system it will become necessary to add an additional amount of refrigerant. This calculation is figured out by measuring the sizes and distances of the total length of liquid line piping installed in feet . All liquid line sizes must be considered.

- Precautions for brazing

Be sure to replace the air inside the tube with nitrogen to prevent oxide film from forming during the brazing process. Be sure to use a damp cloth or other means to cool the valve unit during brazing.

**Work method**

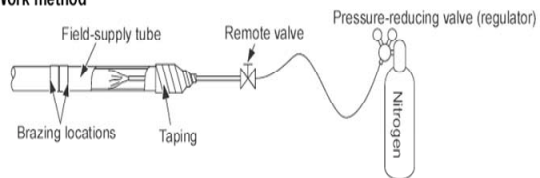

**CAUTION**

1. Be sure to use nitrogen. (Oxygen, CO<sup>2</sup>, and CFC must not be used.)
2. Use a pressure-reducing valve on the nitrogen tank.
3. Do not use agents intended to prevent the formation of oxide film. They will adversely affect the refrigeration oil, and may cause equipment failure.
4. The balance tube is not used if only 1 outdoor unit is installed. Use the unit in the same conditions as when it was shipped from the factory.

# Evacuation and Charging Procedures

Always leak check your connections with Nitrogen. We at Sanyo recommend the 3 stage pressure test. 1st stage 200 psig, 2nd stage 300 psig and then 3rd stage 450 psig. Make sure system holds nitrogen pressure for a 24 hour period.

1. Once, all connections have been leak tested, the system will need to be evacuated down to at least 500 microns. A micron vacuum gauge is required for an accurate measurement of vacuum. The triple evacuation method is strongly recommended.
2. Next calculate additional charge amount and introduce to the system in a liquid form. Please note there is no additional compressor oil needed. Always use an accurate digital refrigerant charging scale for proper charging.

## Additions to Refrigerant Piping

Sanyo does not recommend any of the following to be installed into the refrigerant system piping:

Suction or liquid line driers











Sight Glasses

Oil Traps









Solenoid valves

**DO NOT CHANGE THE SIZE OF THE REFRIGERANT  
PIPING FROM ANY SIZE OTHER THEN SPECIFIED**



● **Examples of the No. of indoor units settings (S005, S004)**

No. of indoor units	Indoor unit setting (S005) (3P DIP switch, blue) 10 20 30	Indoor unit setting (S004) (Rotary switch, red)
1 unit (factory setting)	All OFF 	 Set to 1
11 units	1 ON 	 Set to 1
21 units	2 ON 	 Set to 1
31 units	3 ON 	 Set to 1
40 units	1 & 3 ON 	 Set to 0

● **Examples of refrigerant circuit (R.C.) address settings (required when link wiring is used) (S003, S002)**

System address No.	System address (S003) (2P DIP switch, blue) 10 20	System address (S002) (Rotary switch, black)
System 1 (factory setting)	Both OFF 	 Set to 1
System 11	1 ON 	 Set to 1
System 21	2 ON 	 Set to 1
System 30	1 & 2 ON 	 Set to 0



● **Examples of the No. of outdoor units settings (S006)**

No. of outdoor units	Outdoor unit setting (S006) (3P DIP switch, blue)
1 unit (factory setting)	1 ON 
2 units	2 ON 
3 units	1 & 2 ON 

● **Address setting of main outdoor unit (S007)**

Unit No. setting	Address setting of outdoor unit (S007) (3P DIP switch, blue)
Unit No. 1 (main unit) (factory setting)	

● **Address setting of sub outdoor unit**

Unit No. setting	Address setting of outdoor unit (S007) (3P DIP switch, blue)
Unit No. 2 (sub unit) (factory setting)	2 ON 
Unit No. 3 (sub unit)	1 & 2 ON 

## **Summary of Rotary Dials and Dip Switch Settings**

**(CN100) A.ADD Pins:** These pins are used to initiate auto addressing procedure. (8 & 12 Ton)

**(CN51) A.ADD Pins:** These pins are used to initiate auto addressing procedure. (3 & 5 Ton)

**(S002):** Outdoor system address setting switch. Black Knob

**(S003):** Dip switch setting when outdoor system address exceeds 9 outdoor units.

**(S004):** Switch setting for the number of indoor units hooked up to the outdoor unit. Red Knob

**(S005):** Dip switch setting when indoor unit address exceeds 9 indoor units.

**(S006):** Identifies outdoor unit as #1 or #2 in the case units are piped together as one.

**(S007):** Determines which system is the Main unit and which is the Sub unit.

**(S010):** Identifies how to switch between inverter compressor and constant volume compressor in the event of a failure of either compressor.

**(Terminal Plug):** Used when outdoor unit S-Net wiring is linked between outdoor units.

## Alarm Types & Codes Reminders

- Download a service manual from [www.us.sanyo.com](http://www.us.sanyo.com)
- When an alarm occurs reset the system power and wait 10 minutes then re apply power. Did the system reset?
  - Keep accurate records of alarms and solutions.
- Many error codes are power related. Meaning loss of power to a component.  
and can be reset with cycling the system power.
- If an indoor or outdoor board has been replaced the EPROM chip must also  
be replaced or an error stating unit mismatch or similar will occur.

# Main things to remember

Complete piping pressure test with 450 psi dry nitrogen.

Evacuate and hold system to minimum of 500 microns.

Calculate and add additional R-410A refrigerant charge in liquid form.

Open outdoor unit service valves.

Be sure to apply power to outdoor unit five hours prior to start up to allow crankcase heater to operate.

Set outdoor unit rotary & dip switches to proper system configuration.

Apply power to all indoor units to be addressed.

Initiate auto-addressing sequence by shorting CN100 pins or CN51 pins on respective outdoor unit board. Check and correct alarms, if any.

**E24 = Noise interference** Remove the blue, pink, black, white wires from the bundle. These are the communication wires on terminals 1, 2, 3, and 4 for the communication line.

**P05 = Phase in-balance** Reverse two leads from line voltage. Put your high leg on terminal 3

## **If you run into an E alarm check the following**

U1 and U2 shielded control wiring is open, shorted or not daisy chained properly.

Indoor units are not being powered. No communication with the outdoor unit.

Outdoor unit rotary or dip switches not set properly.

