

Quality, Reliability and Dependability based on over **50** Years of Experience.

## FROZEN FOOD & ICE CREAM CASES

The Dual Temperature Case of  
Choice for All Frozen Foods &  
Ice Creams

<b>TVQ-EXA029K</b>	H: 35 1/2" / W: 70 7/8" / L: 144 5/8" <b>70.5 cu. ft. capacity</b>
<b>TVQ-EXA089K</b>	H: 35 1/2" / W: 70 7/8" / L: 96 3/8" <b>47.0 cu. ft. capacity</b>
<b>TVQ-EXACK</b>	H: 35 1/2" / W: 37 1/4" / L: 70 7/8" <b>15.6 cu. ft. capacity</b>



The TVQ Dual Temperature Cases utilize SANYO's new Energy-efficient Evaporator, providing stable temperature control, longer shelf life, and reduced energy consumption.

- High-efficiency Evaporator Coil
- Stainless Steel Drain Channel
- Self-trapping and Easy-to-clean Drain
- Easy Electrical Connection Point Access
- Adjustable Base Shelving Allowing for Flexible Merchandising
- Varied Standard and Optional Color Choices

Since 1950, SANYO has been recognized as a global technology leader in manufacturing, sales, installation and servicing of Commercial Products worldwide. Our Food Service Products offer energy-efficient evaporators and reduced energy consumption to lessen our global footprint.

**TVQ-EXA029K**

Height: 35 1/2"  
 Length: 144 5/8"  
 Width: 70 7/8"  
 Weight: 1,213 lbs.

**TVQ-EXA089K**

Height: 35 1/2"  
 Length: 96 3/8"  
 Width: 70 7/8"  
 Weight: 816 lbs.

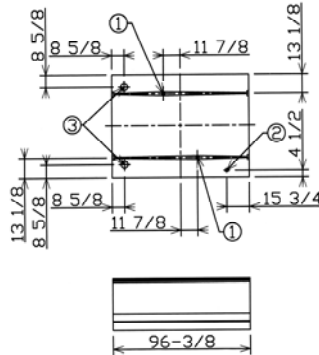
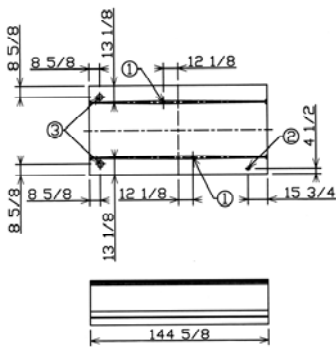
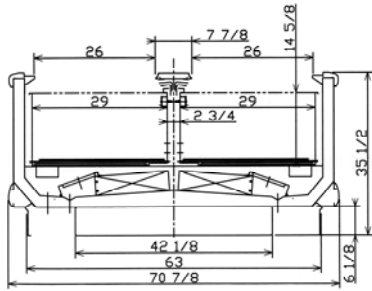

- ① WASTE OUTLET
- ② ELECTRICAL CONNECTION
- ③ REFRIGERATION OUTLET

**ENERGY EFFICIENT**

SANYO'S wide island design conserves energy while maintaining stable cooling performance.

**MAINTENANCE-FRIENDLY**

Ease of maintenance features, including ample space for accessing electrical connection points in the Raceway, and removable Self-trapping Stainless Steel Drain.

**QUALITY FIRST**

SANYO stands behind the quality, reliability and durability of its merchandisers with an industry leading warranty.

**VERSATILE**

The TVQ Merchandiser allows for multiple applications, such as, ice cream, frozen foods, frozen meat, dairy or deli. The height of the wire racks can easily be adjusted for more effective storage and display of goods.

**TVQ-EXACK**

Height: 35 1/2"  
 Length: 70 7/8"  
 Width: 37 1/4"  
 Weight: 397 lbs.

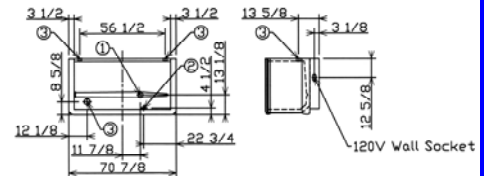

Refrigerant:  
 Evaporator Temperature (Low/Med):  
 Ambient Temperature:  
 Cooling Capacity (Medium Temp.):  
 Cooling Capacity (Frozen):  
 Power Specifications:  
 Display Area:  
 Capacity:  
 Open Dimension:  
 Off-Cycle Defrost:

TVQ-EXA029K	TVQ-EXA089K	TVQ-EXACK
R404A / R407A		
- 20 degrees Fahrenheit / 19 degrees Fahrenheit		
75 degrees Fahrenheit, 55% Relative Humidity		
1,338W, 380BTU/h/ft	892W, 380BTU/h/ft	350W, 1,194BTU/h/ft
1,695W, 482BTU/h/ft	1,130W, 482BTU/h/ft	440W, 1,501BTU/h/ft
Single Phase 120V		
58 sq. ft.	38.8 sq. ft.	12.8 sq. ft.
70.5 cu. ft.	47.0 cu. ft.	15.6 cu. ft.
26" x 2		26"
30 minute cycles, every 12 hours		

NOTE: The appearances and/or specifications of the products referred in this publication are subject to partial changes without prior notice

Manufactured by:

**SANYO**  
 SANYO E & E Corporation  
 2001 Sanyo Avenue  
 San Diego, CA 92154-6229  
 USA

Distributed by:

**SANYO**  
 SANYO North America Corporation  
 Commercial Solutions Division  
 2001 Sanyo Avenue  
 San Diego, CA 92154-6229  
 USA  
 Toll Free USA: 800-95-SANYO (72696) – Fax: 619-470-5040  
<http://us.sanyo.com/Food-Solutions>

Marketed by: