

## INSTRUCTION

## MCO-80IC

### CO<sub>2</sub> Incubator



# CONTENTS

INTRODUCTION	P. 2
PRECAUTIONS FOR SAFE OPERATION	P. 3
LABELS ON THE UNITS	P. 6
ENVIRONMENTAL CONDITIONS	P. 7
INCUBATOR COMPONENTS	P. 8
Control panel and keypad	P. 11
Remote alarm terminal	P. 13
INSTALLATION SITE	P. 14
INSTALLATION	P. 15
Connection of CO <sub>2</sub> gas cylinder	P. 16
PREVENT CONTAMINATION	P. 17
CAUTIONS FOR CULTURE	P. 18
START-UP OF UNIT	P. 19
SETTING OF CHAMBER TEMPERATURE AND CO <sub>2</sub> DENSITY	P. 20
KEY LOCK FUNCTION	P. 23
ALARMS & SAFETY FUNCTIONS	P. 24
SETTING OF ALARM RESUME TIME	P. 26
Operation after power failure	P. 26
ROUTINE MAINTENANCE	P. 27
Sterilizing of chamber and attachments	P. 27
Filling the humidifying pan	P. 29
CALIBRATION	P. 30
Temperature calibration	P. 30
CO <sub>2</sub> calibration	P. 30
TROUBLESHOOTING	P. 31
DISPOSAL OF UNIT	P. 33
AUTOMATIC CO <sub>2</sub> CYLINDER CHANGEOVER	P. 38
SPECIFICATIONS	P. 39
PERFORMANCE	P. 40
SAFETY CHECK SHEET	P. 41

# INTRODUCTION

---

- Read this manual carefully before using the appliance and follow the instructions for safety operation.
- Sanyo never guarantee any safety if the appliance is used for any objects other than intended use or used by any procedures other than those mentioned in this manual.
- Keep this manual in an adequate place to refer to it as necessary.
- The contents of the manual will be subjected to change without notice due to the improvement of performance or functions.
- Contact Sanyo sales representative or agent if any page of the manual is lost or page order is incorrect.
- Contact Sanyo sales representative or agent if any point in this manual is unclear or if there are any inaccuracies.
- No part of this manual may be reproduced in any form without the expressed written permission of Sanyo.

# PRECAUTIONS FOR SAFE OPERATION

It is imperative that the user complies with this manual as it contains important safety advice.

Items and procedures are described so that you can use this unit correctly and safely. If the precautions advised are followed, this will prevent possible injury to the user and any other person.

Precautions are illustrated in the following way:



## **WARNING**

Failure to observe WARNING signs could result in a hazard to personnel possibly resulting in serious injury or death.

## **CAUTION**

Failure to observe CAUTION signs could result in injury to personnel and damage to the unit and associated property.

Symbol shows;

-  this symbol means caution.
-  this symbol means an action is prohibited.
-  this symbol means an instruction must be followed.

Be sure to keep this manual in a place accessible to users of this unit.

< Label on the unit >

















This mark is labeled on the cover in which the electrical components of high voltage are enclosed to prevent the electric shock.  
The cover should be removed by a qualified engineer or a service personnel only.

## **WARNING**

As with any equipment that uses CO<sub>2</sub> gas, there is a likelihood of oxygen depletion in the vicinity of the equipment. It is important that you assess the work site to ensure there is suitable and sufficient ventilation. If restricted ventilation is suspected, then other methods of ensuring a safe environment must be considered. These may include atmosphere monitoring and warning devices.













# PRECAUTIONS FOR SAFE OPERATION

## **WARNING**

-  **Do not use the unit outdoors.** Current leakage or electric shock may result if the unit is exposed to rain water.
-  **Only qualified engineers or service personnel should install the unit.** The installation by unqualified personnel may cause electric shock or fire.
-  **Install the unit on a sturdy floor and take an adequate precaution to prevent the unit from turning over.** If the floor is not strong enough or the installation site is not adequate, this may result in injury from the unit falling or tipping over.
-  **Never install the unit in a humid place or a place where it is likely to be splashed by water.** Deterioration of the insulation may result which could cause current leakage or electric shock.
-  **Never install the unit in a flammable or volatile location.** This may cause explosion or fire.
-  **Never install the unit where acid or corrosive gases are present** as current leakage or electric shock may result due to corrosion.
-  **Always ground (earth) the unit to prevent electric shock.** If the power supply outlet is not grounded, it will be necessary to install a ground by qualified engineers.
-  **Never ground the unit through a gas pipe, water main, telephone line or lightning rod.** Such grounding may cause electric shock in the case of an incomplete circuit.
-  **Connect the unit to a power source as indicated on the rating label attached to the unit.** Use of any other voltage or frequency other than that on the rating label may cause fire or electric shock.
-  **Never store volatile or flammable substances** in this unit if the container cannot be sealed. These may cause explosion or fire.
-  **Do not insert metal objects such as a pin or a wire into any vent, gap or any outlet on the unit.** This may cause electric shock or injury by accidental contact with moving parts.
-  **Use this unit in safe area when treating the poison, harmful or radiate articles.** Improper use may cause bad effect on your health or environment.
-  **Turn off the power switch (if provided) and disconnect the power supply to the unit prior to any repair or maintenance** of the unit in order to prevent electric shock or injury.
-  **Do not touch any electrical parts (such as power supply plug) or operate switches with a wet hand.** This may cause electric shock.







# PRECAUTIONS FOR SAFE OPERATION

## **WARNING**

-  **Ensure you do not inhale or consume medication or aerosols** from around the unit at the time of maintenance. These may be harmful to your health.
-  **Never splash water directly onto the unit** as this may cause electric shock or short circuit.
-  **Never put containers with liquid on the unit** as this may cause electric shock or short circuit when the liquid is spilled.
-  **Never bind, process, or step on the power supply cord, or never damage or break the power supply plug.** A broken supply cord or plug may cause fire or electric shock.
-  **Do not use the supply cord if its plug is loose.** Such supply cord may cause fire or electric shock.
-  **Never disassemble, repair, or modify the unit yourself.** Any such work carried out by an unauthorized person may result in fire, or electric shock or injury due to a malfunction.
-  **Disconnect the power supply plug if there is something wrong with the unit.** Continued abnormal operation may cause electric shock or fire.
-  **When removing the plug from the power supply outlet, grip the power supply plug, not the cord.** Pulling the cord may result in electric shock or fire by short circuit.
-  **Disconnect the power supply plug** before moving the unit. Take care not to damage the power cord. A damaged cord may cause electric shock or fire.
-  **Disconnect the power plug when the unit is not used for long periods.** Keeping the connection may cause electric shock, current leakage, or fire due to the deterioration of insulation.
-  **If the unit is to be stored unused in an unsupervised area for an extended period, ensure that children do not have access and that doors cannot be closed completely.**
-  **The disposal of the unit should be accomplished by appropriate personnel.** Remove doors to prevent accidents such as suffocation.
-  **Do not put the packing plastic bag within reach of children** as suffocation may result.







# PRECAUTIONS FOR SAFE OPERATION

## CAUTION

-  **Use a dedicated power source** (a dedicated circuit with a breaker) as indicated on the rating label attached to the unit. A branched circuit may cause fire resulting from abnormal heating.
-  **Connect the power supply plug to the power source firmly after removing the dust on the plug.** A dusty plug or improper insertion may cause a heat or ignition.
-  **Never store corrosive substances such as acid or alkali** in this unit if the container cannot be sealed. These may cause corrosion of inner components or electric parts.
-  **Check the setting when starting up of operation after power failure or turning off of power switch.** The stored items may be damaged due to the change of setting.
-  **Be careful not to tip over the unit** during movement to prevent damage or injury.
-  **Prepare a safety check sheet** when you request any repair or maintenance for the safety of service personnel.

## LABELS ON THE UNIT

Some warning and/or caution labels are attached on the unit. Following shows the description of such labels.

	This label is on the cover in which the electrical components of high voltage are enclosed to prevent the electric shock. The cover should be removed by a qualified engineer or a service personnel only.
	This symbol means UV caution.
	This symbol means attention or refer to document.
	This symbol means hot surface.
	This symbol means earth.
	This symbol means power switch "ON".
	This symbol means power switch "OFF".

# ENVIRONMENTAL CONDITIONS

This equipment is designed to be safe at least under the following conditions (based on the IEC-1010-1):

- Indoor use;
- Altitude up to 1000 m;
- Ambient temperature 20°C to 35°C
- Maximum relative humidity 80% for temperature up to 31°C decreasing linearly to 50% relative humidity at 40°C;
- Mains supply voltage fluctuations not to exceed  $\pm 10\%$  of the nominal voltage;
- Other supply voltage fluctuations as stated by the manufacturer;
- Transient overvoltages according to Installation Categories (Overvoltage Categories) II; For mains supply the minimum and normal category is II;
- Pollution degree 2 in accordance with IEC 664.

# INCUBATOR COMPONENTS

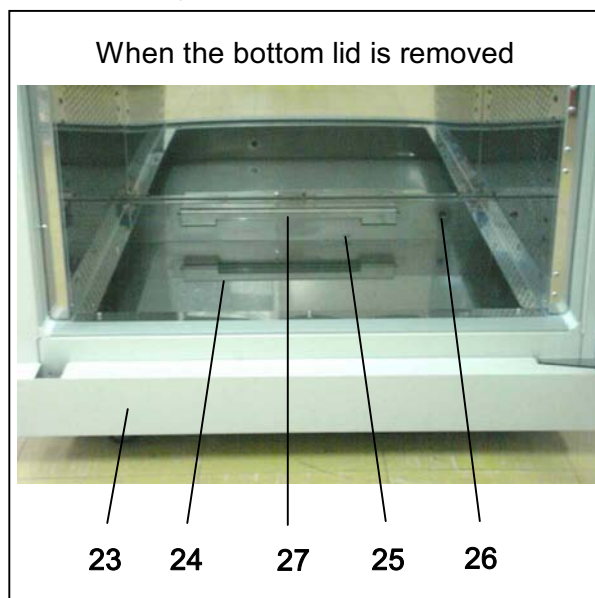
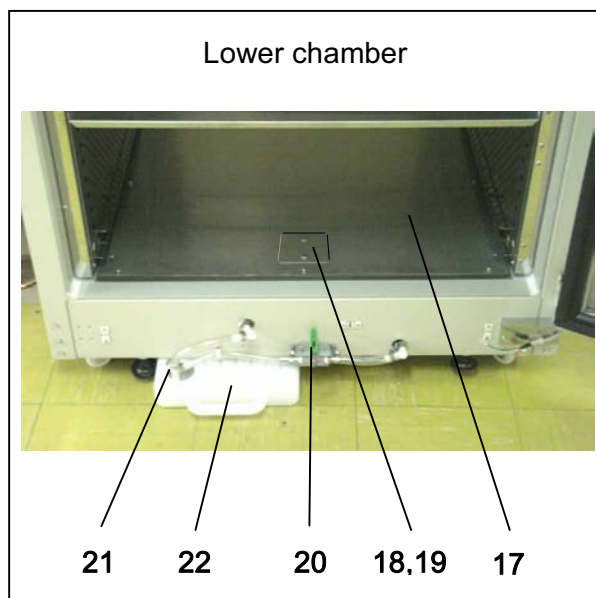
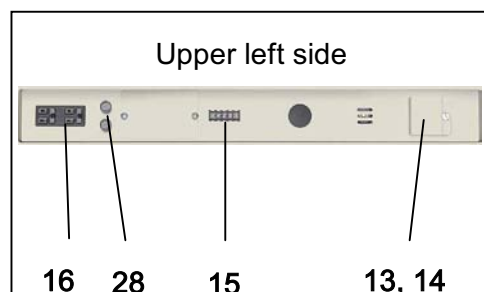
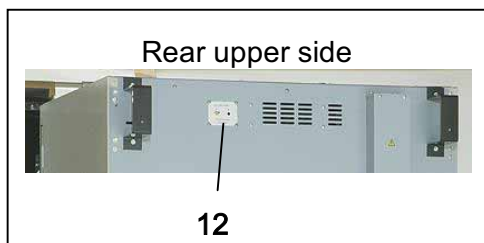
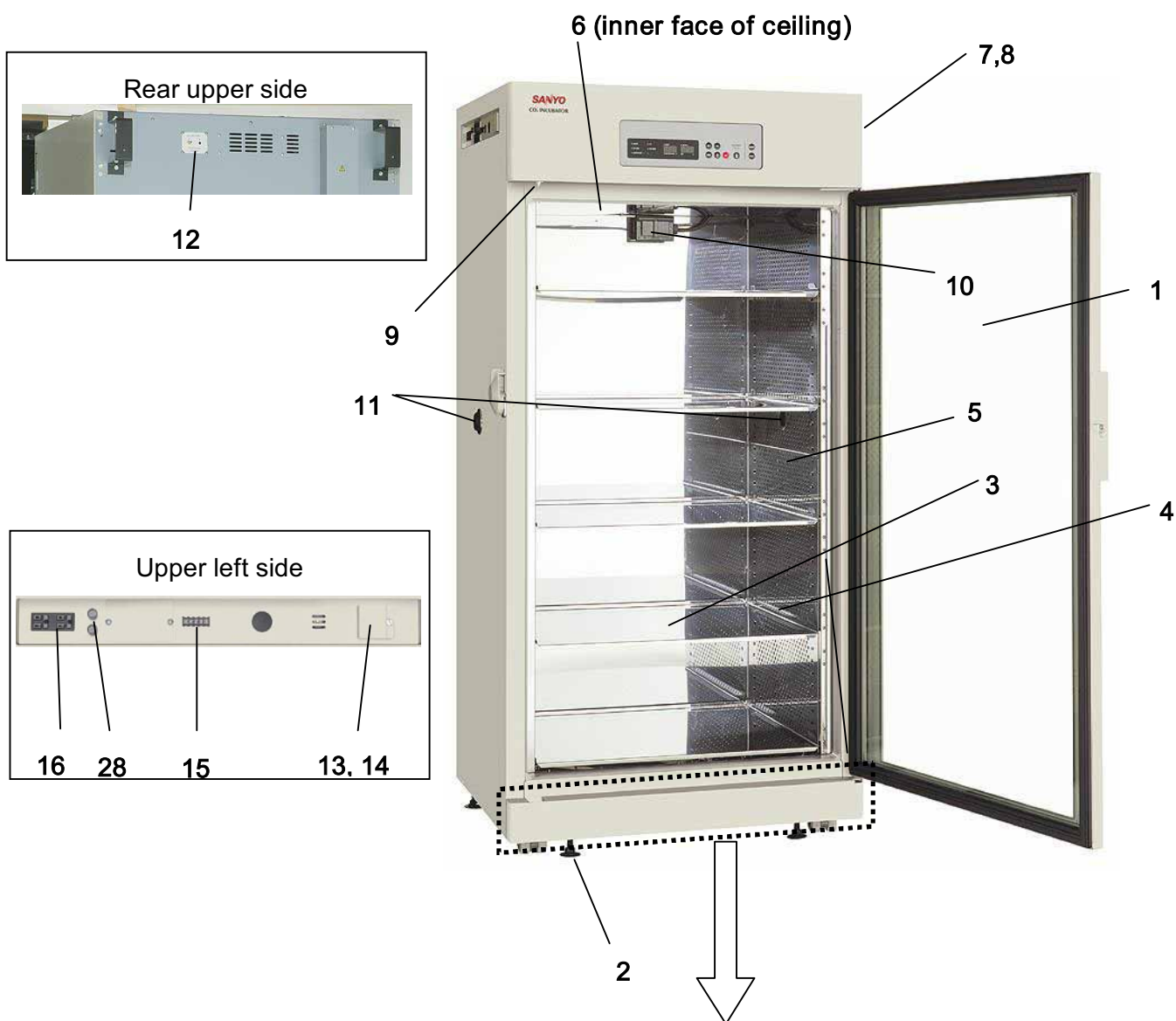

# INCUBATOR COMPONENTS

1. **Outer door:** Sticks to frame with magnetic seal. Door heater is installed in the door panel. The door window is double glass. The door opening is reversible. Contact Sanyo representative or agent to change the door hinge from left to right or vice versa.
2. **Leveling foot:** Screw type for adjusting the height. Adjust the foot so that the unit can be level.
3. **Tray:** Can be pulled toward you.
4. **Tray support:** Can be removed by lifting the front side and pulling toward you.
5. **Side duct:** Flow path for circulating air. Removable.
6. **Fan (inner face of ceiling)**
7. **Sample air outlet:** This also functions as an internal gas outlet. Normally, cover this outlet with the sample air outlet cap.
8. **Sample air outlet cap:** Always attach this cap except at the time of using of sample air outlet.
9. **Door switch:** Detects the door opening/closing and stops the circulating fan and electromagnetic valve for CO<sub>2</sub> when door is open. UV lamp is also deactivated by door opening (when an optional UV system kit MCO-80UVS is installed).
10. **Inside power outlet:** AC 115 V and up to 3 A in total. It is possible to use on the condition that inner temperature below 40 °C and humidity below 50%R.H. At the first time to operate, press the reset button between two inside power outlets.
11. **Access port:** When not in use, cap them with two attached silicon caps on outside.
12. **Connecting port for CO<sub>2</sub> gas pipe (rear side):** When an optional component MCO-80GC (automatic CO<sub>2</sub> cylinder changeover system) is installed, both A and B are available. If MCO-80GC is not used, only A is available. Refer to page 16 for gas cylinder connection. Ensure that the gas pressure is set at 0.1 MPaG (1.0 kgf/cm<sup>2</sup>G, 14.5 psiG). Refer to page 38 for automatic CO<sub>2</sub> cylinder changeover system.
13. **Power switch:** Main switch of the unit. Also functions as an over-current breaker.
14. **Power switch cover:** Power switch is covered by a switch cover to prevent the accidental push. To turn on or off the switch, remove the switch cover by loosening the screw.
15. **Remote alarm terminal:** Refer to page 13.
16. **Outer power outlet:** AC 115 V, and up to 3 A in total.
17. **Bottom lid:** Prevents UV light being exposed to the chamber. Just lift to remove for cleaning. See page 27 for details.
18. **Water supply inlet cover:** When filling the pan, remove a screw and rotate the cover.
19. **Water supply inlet:** Usually closed with water supply inlet cover.
20. **Drain valve:** Open the drain valve to drain water from the humidifying pan.
21. **Drain outlet:** Insert the drain outlet into the attached drain tank installed under the unit.
22. **Drain tank**
23. **Front panel lower cover:** Detach it when draining water from the humidifying pan. See to page 27 for details.
24. **Humidifying pan:** Use sterile distilled water of approximately 20 L to fill the pan.
25. **Water level sensor for humidifying pan:** Detects the water level in the humidifying pan.

# INCUBATOR COMPONENTS

---

**26. Auto water supply inlet:** When an optional component MCO-80AS (automated water supply system kit) is installed, water is supplied from here.

**27. UV lamp (option)**

**28. Fuse:** upper: for inside power outlet 125 V, 3.15 A. Normal blow type.

lower: for outer power outlet 125 V, 1 A. Normal blow type.

# INCUBATOR COMPONENTS

## Control panel and keypad

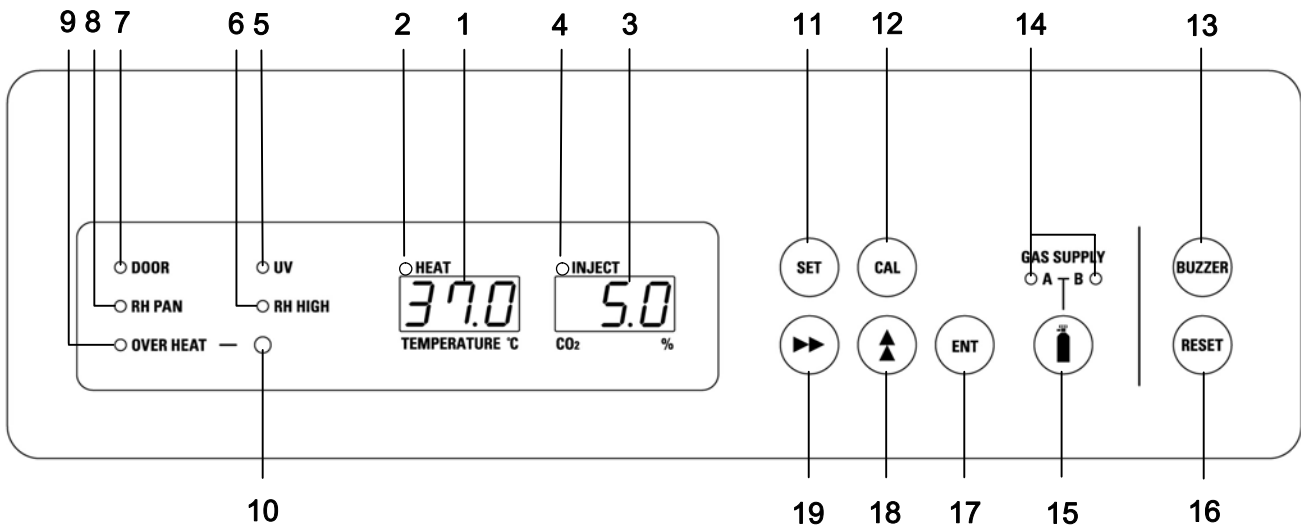

- 1. Digital temperature indicator (TEMPERATURE °C):** Normally, this indicator shows the chamber temperature. In the setting mode, it shows the set value of the chamber temperature. If the self diagnostic function detects any abnormality, an error code will be displayed.
- 2. Heater lamp (HEAT):** This lamp lights when the heater is energized.
- 3. Digital CO<sub>2</sub> density indicator (CO<sub>2</sub> %):** Normally, this indicator shows the CO<sub>2</sub> concentration in the chamber. In the setting mode, it indicates the set value of the CO<sub>2</sub> concentration.
- 4. CO<sub>2</sub> inject lamp (INJECT):** This lamp lights when CO<sub>2</sub> gas is being injected.
- 5. UV indicator (UV):** This lamp lights when the UV lamp is ON [when an optional component MCO-80UVS (UV system kit) is installed]. The blink of this indicator recommends the replacement of UV lamp.
- 6. High humidity mode indicator (RH HIGH):** This lamp lights when the high humidity mode is activated. See page 21 for changing to the high humidity mode.
- 7. Door lamp (DOOR):** This lamp lights when the outer door is open.
- 8. Water level alarm lamp (RH PAN):** This lamp flashes when the water in the humidifying pan is less than approximately 5 liters.
- 9. Over heat lamp (OVER HEAT):** This lamp lights when the chamber temperature reaches the upper limit set value. It starts to blink when the chamber temperature is back in below the upper limit set value.
- 10. Upper limit regulator:** This regulator is used to set the upper temperature limit.
- 11. Set key (SET):** Pressing this key to enter the setting mode, and the digits to be set will flash.
- 12. Calibration key (CAL):** By pressing this key for approximately 5 seconds, the unit enters calibration function mode.
- 13. Alarm buzzer stop key (BUZZER):** Press this key to silence the buzzer when the alarm operates and the buzzer sounds.
- 14. CO<sub>2</sub> gas supply line indicator (A/B):** The lamp for the supply line currently in use lights up provided that MCO-80GC automatic CO<sub>2</sub> cylinder changeover system is installed.
- 15. CO<sub>2</sub> gas supply line switching key :** This key to select CO<sub>2</sub> gas supply line is available only when an automatic CO<sub>2</sub> cylinder changeover system MCO-80GC (option) is installed. When one CO<sub>2</sub> cylinder is empty, the CO<sub>2</sub> is supplied by the other cylinder automatically.
- 16. Upper limit alarm reset key (RESET):** Press this key while the over heat lamp blinks to reset the alarm.
- 17. Enter key (ENT):** Pressing this key memorizes the set value in the controller.

# INCUBATOR COMPONENTS

## Control panel and keypad

**18. Numerical value shift key (▲):** Pressing this key in the setting mode causes the numerical value to shift. In key lock mode, pressing this key makes key lock ON or OFF.

**19. Digit shift key (▶▶):** Pressing this key in the setting mode causes the changeable digit to shift. Pressing this key more than 5 seconds enters key lock mode. See page 23 for the key lock.

# INCUBATOR COMPONENTS

## Remote alarm terminal

The remote alarm terminal is located at the upper left side of the unit.

The remote alarm terminal is a contact output.

Normal : Open between COM to N.O.

Abnormal: Open between COM to N.C.

Contact capacity : DC 30 V, 2 A

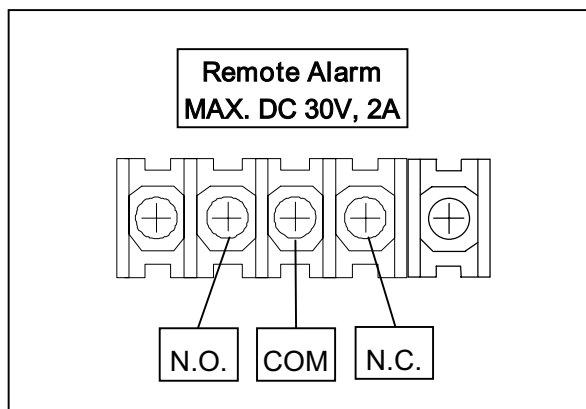

### Note:

- When the power switch is OFF or the power failure condition, the contact output is CLOSE.
- The remote alarm cannot be silenced by pressing the alarm buzzer stop key (BUZZER) since the remote alarm is not conjunct with the alarm buzzer stop key (BUZZER).

# INSTALLATION SITE

To operate this unit properly and to obtain maximum performance, install the unit in a location with the following conditions:

■ **A location not subjected to direct sunlight**

Do not install the unit under direct sunlight. Installation in a location subjected to direct sunlight cannot obtain the intended performance.

■ **A location with clean air and adequate ventilation** (Small and sealed room is not recommended.)

 **WARNING**

**Ventilate a room air occasionally when using CO<sub>2</sub> gas for control.** The gas density will increase in an enclosed small room and high level of gas density can be hazardous to health. In addition, avoid inhaling the chamber air directly when opening the door if CO<sub>2</sub> gas is used.

Si l'appareil est utilisé dans un endroit restreint, le niveau de la densité CO<sub>2</sub> de l'air peut s'élever et peut être nocif aux humains. Évitez d'aspirer l'air provenant de l'intérieur de l'appareil quand vous ouvrez la porte.

■ **A location away from heat generating sources**

Avoid installing the unit near heat-emitting appliances such as a heater or a boiler etc. Heat can decrease the intended performance of the unit.

■ **A location with a sturdy and level floor**

Always install the unit on a sturdy and level floor. The uneven floor or tilted installation may cause failure or injury. Install the unit in stable condition to avoid the vibration or noise. Unstable condition may cause vibration or noise.

 **WARNING**

**Install the unit on a sturdy floor.** If the floor is not strong enough or the installation site is not adequate, this may result in injury from the unit falling or tipping over.

**Select a level and sturdy floor for installation.** This precaution will prevent the unit from tipping. Improper installation may result in water spillage or injury from the unit tipping over.

■ **A location not prone to high humidity**

Install the unit in the ambient of 80% R.H. or less humidity. Installation under high humidity may cause current leakage or electric shock.

 **WARNING**

**Do not use the unit outdoors.** Current leakage or electric shock may result if the unit is exposed to rain water.

**Never install the unit in a humid place or a place where it is likely to be splashed by water.** Deterioration of the insulation may result which could cause current leakage or electric shock.

■ **A location without flammable or corrosive gas**

Never install the unit in a flammable or volatile location. This may cause explosion or fire or may result in the current leakage or electric shock by the corrosion of the electrical components.

■ **5°C higher than the ambient temperature**

The chamber temperature must be at least 5°C higher than the ambient temperature. For example, the chamber temperature is set to 37°C, the ambient temperature must be less than 32°C. Keep the ambient temperature in adequate range.

# INSTALLATION

## 1. Remove the packaging materials and tapes

Remove all transportation packaging materials and tapes. Open the doors and ventilate the unit. If the outside panels are dirty, clean them with a neutral detergent and wipe it up with a wet cloth.

## 2. Adjust the leveling feet

Extend the leveling feet by rotating them counterclockwise to contact them to the floor. Ensure the unit is level.

## 3. Fix the unit

Two fixtures are attached to the rear of the frame. Fix the frame to the wall with these hooks and rope or chain.

## 4. Ground (earth)

### **WARNING**

**Use a power supply outlet with ground (earth)** to prevent electric shock. If the power supply outlet is not grounded, it is necessary to install a ground by qualified engineers.

**Never ground the unit through a gas pipe, water main, telephone line or lightning rod.** Such grounding may cause electric shock in the case of an incomplete circuit.

#### ● **If not used**

When the unit is not used, dispose the water in the humidifying pan and remove any moisture in the chamber completely. Check that the chamber is completely dry before closing the doors.

#### ● **Before moving the unit**

Empty the humidifying pan completely before moving the unit. Spilled or splashed water may cause current leakage or electric shock.

# INSTALLATION

## Connection of CO<sub>2</sub> gas cylinder

### WARNING

Check the gas type and ensure that it is fit for the purpose. Make sure that all pipes are connected correctly and are not liable to become disconnected. Ensure that the gas pressure is set at the specified value. Improper connection of the gas pipe or use of incorrect gas pressure may result in leakage of CO<sub>2</sub> gas. Elevated level of CO<sub>2</sub> gas can be hazardous to health and may lead to asphyxiation and risk of death.

Use a liquefied CO<sub>2</sub> gas cylinder, not a siphon (dip tube) type. The CO<sub>2</sub> gas should be 99.5% or more pure.

1. Use a regulator rated at 25 MPaG (250 kgf/cm<sup>2</sup>G, 3600 psiG) on the primary side and 0.2 MPaG (2.0 kgf/cm<sup>2</sup>G, 30 psiG) on the secondary side with flow rate of 77 L/min.
2. Using the gas supply pipe provided, connect the pressure regulator to the CO<sub>2</sub> inlet located at the rear left hand side of the CO<sub>2</sub> incubator.
3. Set the CO<sub>2</sub> pressure on the secondary side to 0.1 MPaG (1.0 kgf/cm<sup>2</sup>G, 14.5 psiG) (at gas injection). Excessive pressure may cause disconnection of internal pipes inside the CO<sub>2</sub> incubator which will result in leakage of CO<sub>2</sub> gas into the atmosphere. Elevated level of CO<sub>2</sub> gas can be hazardous to health and may lead to asphyxiation and risk of death. The repair of the incubator will be necessary if the internal pipe is disconnected.
4. Check that no gas is leaking at any point where the pipe connects with the CO<sub>2</sub> regulator or the CO<sub>2</sub> incubator.

#### Note:

- Refer to “Procedure for replacement of gas cylinder” enclosed with the unit at the time of replacement.
- The incubator, including the gas supply pipes and services must be examined at frequent intervals to ensure they are safe. Ensure that items such as pipes are replaced if there is any sign of deterioration.

# PREVENT CONTAMINATION

To prevent contamination of the chamber, select an appropriate location for installation as well as the complete disinfection of the chamber components.

- **Avoid hot and humid location**

Avoid location with high temperature and/or humidity as the presence of bacteria in the air is greater than in normal environment.

- **Avoid drafty location and location with many passers-by**

Avoid locations near doors, air conditioners, fans, etc., where slight breezes can facilitate the entry of bacteria into the chamber.

- **Installation in a sterile room**

To get the cultivation more efficiently, install the unit in a sterile room.

- **Use clean containers**

The contamination is mainly caused by the containers such as Petri dishes or bottles stored in the chamber. Always keep the containers clean.

- **Always keep the chamber clean**

The condensation may be caused on the inside of the door by spilled water from humidifying pan or opening of outer door for long period. Wipe off the condensation completely with a sterile dry gauze. Especially when the culture medium is spilled, clean and disinfect the chamber immediately. Refer to page 27 "Routine maintenance" for details.

- **Keep the inside panels dry**

To protect the inside of the unit from contamination, the inside panels should always be kept dry. If water is spilled from a humidifying pan or if the door is kept open for a long period, condensation will form on the panels, allowing germs to breed. In such a case, wipe away the water with a dry sterile gauze. Particularly, if the medium is spilled, wipe it up immediately and sterilize the area.

- **Fill the humidifying pan with sterile distilled water**

Always use sterile distilled water of approximately 20 L to fill the pan. The water level alarm lamp (RH PAN) on the control panel flashes when the amount of water is less than approximately 5 L. Refill the sterile distilled water to the pan when the water level alarm lamp (RH PAN) blinks. Note that when low temperature water is poured, the chamber temperature drops significantly. Clean the pan once a month.

- **Do not place the unit in the direct air flow from an air conditioning system**

Cool air from an air conditioning system may cause condensation and lead to possible contamination.

# CAUTIONS FOR CULTURE

- **Do not subject to direct air flow**

Do not allow the air for air conditioning to hit the unit or door directly. Direct hit may cause condensation or contamination.

- **Do not block holes on the side duct with the culture vessels.**

When storing cultures in the chamber, take care not to block holes on the side duct with the Petri dishes or roller-bottle racks to allow adequate air circulation. Blockage of holes may result in uneven temperature distribution and CO<sub>2</sub> concentration in the chamber.

- **Stored materials**

Never place acid or alkaline materials or materials that release corrosive gas in the chamber. Such materials can cause failure resulting from discoloration or corrosion.

- **Open/close the doors gently**

Ensure you close the doors gently. Robust closing may cause spillage of medium, incomplete closing, or damage of gasket.

- **Fix the tray supports and trays securely**

Incomplete installation may cause injury or damage.

- **Never lean or press on the glass.**

Intentional force may cause injury if the glass breaks.

- **Do not lean on the door**

This may cause injury, current leakage, or electric shock if the unit tips over or door drops out.

- **Alarm**

Always investigate the cause and fix the alarm condition immediately when the alarm is activated. Refer to page 24 for alarm details.

# START-UP OF UNIT

When start the test operation or the operation, follow these steps as below.

1. Install the unit referring to “INSTALLATION” on page 15.
2. Remove all transportation packaging materials and tapes. Then clean and sterilize the chamber and internal attachments. Refer to “Sterilizing of chamber and attachment” on page 27.
3. Place the drain tank under the unit. Insert a drain outlet into the hole of drain tank.
4. Fill the humidifying pan with sterile distilled water of about 20 liters. (Refer to page 29)
5. Turn on the power switch located on the upper left side of the unit.



## **CAUTION**

**Do not put the packing plastic bag within reach of children** as suffocation may result.

# SETTING OF CHAMBER TEMPERATURE AND CO<sub>2</sub> DENSITY

Table below shows the basic procedure for setting the chamber temperature and CO<sub>2</sub> density. The upper limit alarm temperature setting is also shown in the table. Perform key operations in the sequence indicated in the table. The example in the table is based on the assumption that the desired temperature is 37°C and CO<sub>2</sub> density is 5%. Adjustment of the upper limit regulator should be executed after the chamber temperature reaches the stable condition.

**Note:** The unit is set at the factory so that the chamber temperature is 37°C and CO<sub>2</sub> control is 0%.

Allow at least 4 hours until the next setting after setting of desired chamber temperature and setting CO<sub>2</sub> density to 0%, at the time of first start-up or start-up after no use for long term.

## Basic operation sequence (Example: Chamber temperature; 37°C, CO<sub>2</sub> density; 5%)

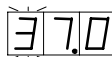
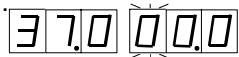
	Description of operation	Key operated	Indication after operation
1	Turn the power switch ON.	----	The current chamber temperature is displayed in temperature indicator.
2	Press set key.	SET	The left digit is flashed. 
3	By pressing digit shift key and numerical value shift key, set the figure to 37.0.	▶▶	When pressed, the changeable digit is shifted.
		▲	When pressed, the figure of settable digit changes.
4	Press enter key.	ENT	Set temperature is memorized. Left digit in digital CO <sub>2</sub> density indicator is flashed. 
5	By pressing digit shift key and numerical value shift key, set the figure to 05.0.	▶▶	When pressed, the changeable digit is shifted.
		▲	When pressed, the figure of settable digit changes.
6	Press enter key.	ENT	Set CO <sub>2</sub> density is memorized.
7	(Executed after the chamber temperature reaches the stable condition) Adjust upper limit regulator so that the alarm temp. is 1°C higher than chamber temperature.		In digital CO <sub>2</sub> density indicator, HI is displayed. In digital temperature indicator, upper limit temp. is displayed. The upper limit temp. can be changed by turning upper limit regulator.
8	Press enter key.	ENT	This is the end of set mode and the indicators display current temperature and CO <sub>2</sub> density.

### Note:

- In each set mode, if the change of the setting is not necessary, pressing set key (SET) skips to next set mode.
- When the CO<sub>2</sub> density is set to 00.0, the control is OFF regardless of chamber density.
- The upper limit temperature set value will change when the regulator is turned even if the unit is not in set mode, because the alarm circuit is an independent circuit.
- In each set mode, the indicator returns to the current temperature and CO<sub>2</sub> density display mode automatically when 90 seconds has passed without any key operation.
- Do not use Calibration key (CAL) on the control panel under normal conditions. Pressing CAL key leads the calibration mode. Incorrect operation may cause interferences in the basic functions of the unit. When the calibration mode is activated by mistake, remain untouched any keys for 90 seconds to automatically restore the current value indication mode.

# SETTING OF CHAMBER TEMPERATURE AND CO<sub>2</sub> DENSITY

This product usually operates in approximately R.H.80% setting. For approximately 90%R.H. operation, the high humidity mode needs to be set (the normal mode is set as default setting at the factory). Upper table shows the procedure to set the high humidity mode. Lower table shows the procedure to set of the no humidifying mode which doesn't humidify at all.

F26	Mode	Function
000	No humidifying mode	No humidifying
001	Normal mode	Inner humidity 80%R.H.
002	High humidity mode	Inner humidity 90%R.H.

## High humidity mode setting procedure

	Description of operation	Key operated	Indication after operation
1		----	The current chamber temperature is displayed.
2	Press calibration key.	CAL	The third digit on the digital temperature display is flashed.
3	By pressing digit shift key and numerical value key, set the figure to F26.		When pressed, the settable digit is shifted.
			When pressed, the figure of settable digit changes.
4	Press enter key.	ENT	The current recovery time is displayed in digital CO <sub>2</sub> density indicator. The second digit is flashed.
5	By pressing numerical value key, set the value to 002.		When pressed, the figure of the second digit changes.
6	Press enter key.	ENT	Set alarm recovery time value is memorized. The current chamber temperature is displayed.

## No humidifying mode setting procedure

	Description of operation	Key operated	Indication after operation
1		----	The current chamber temperature is displayed.
2	Press calibration key.	CAL	The third digit on the digital temperature display is flashed.
3	By pressing digit shift key and numerical value key, set the figure to F26.		When pressed, the settable digit is shifted.
			When pressed, the figure of settable digit changes.
4	Press enter key.	ENT	The current recovery time is displayed in digital CO <sub>2</sub> density indicator. The second digit is flashed.
5	By pressing numerical value key, set the value to 000.		When pressed, the figure of the second digit changes.
6	Press enter key.	ENT	Set alarm recovery time value is memorized. The current chamber temperature is displayed.

### Note:

- In the no humidifying mode, the water level sensor function is cancelled (Water level alarm lamp (RH PAN) does not light).
- In each set mode, if the change of the setting is not necessary, pressing set key (SET) skips to next set mode.

# SETTING OF CHAMBER TEMPERATURE AND CO<sub>2</sub> DENSITY

- In each set mode, the indicator returns to the current temperature and CO<sub>2</sub> density display mode automatically when 90 seconds has passed without any key operation.
- Do not use calibration key (CAL) on the control panel under normal conditions. Pressing calibration key (CAL) leads the calibration mode. Incorrect operation may cause interferences in the basic functions of the unit. When the calibration mode is activated by mistake, remain untouched any keys for 90 seconds to automatically restore the current value indication mode.

## CAUTION

When operating in the no humidifying mode, drain all the water from the pan. Remains of water may result in increasing humidity in chamber to about 80%R.H.

# KEY LOCK FUNCTION

This unit is provided with a key lock function. When the key lock is ON, change of temperature or CO<sub>2</sub> density setting through the key pad is not available.

**Note:** The key lock is set in OFF mode (L0) at the factory.

Display	Mode	Function
	Key lock is OFF	Enable to change of temperature and CO <sub>2</sub> setting
	Key lock is ON	Disable to change of temperature or CO <sub>2</sub> setting

## Procedure for key lock setting (change from key lock OFF to key lock ON)

	Description of operation	Key operated	Indication after operation
1		----	The current chamber temperature and CO <sub>2</sub> density are displayed.
2	Press digit shift key for 5 seconds.		L0 is displayed in the digital temperature indicator.
3	Press numerical value shift key and scroll the figure to 1.		When pressed, the figure of settable digit changes.
4	Press enter key.	ENT	The key lock is set to ON. The current chamber temperature is displayed.

### Note:

- The key lock function is available for temperature and CO<sub>2</sub> density setting.
- To cancel the key lock, set to L0 in the above procedure.

# ALARMS & SAFETY FUNCTIONS

This unit has the alarms and safety functions shown in table below, and also self diagnostic functions.

## Alarms and safety functions

Alarm & Safety	Situation	Indication	Buzzer	Safety operation
Upper limit temperature alarm	If the chamber temperature exceeds the upper limit alarm temperature set value.	Over heat lamp lights. E12 or E16 and chamber temperature are displayed alternately.	Continuous tone	Heater OFF Remote alarm
Automatic set temperature alarm	If the chamber temperature deviates from the set temperature by $\pm 1.0^{\circ}\text{C}$ or more.	All digits on the digital temperature indicator blink.	Intermittent tone with 15 minutes delay.	Remote alarm with 15 minutes delay
Automatic set CO <sub>2</sub> density alarm	If the chamber CO <sub>2</sub> density deviates from the set value by $\pm 1.0\%$ or more.	All digits on the digital CO <sub>2</sub> density indicator blink.	Intermittent tone with 15 minutes delay.	Remote alarm with 15 minutes delay
Auto-return	When there is no key pressing in each setting mode for 90 seconds.	Normal display mode.	-----	The setting mode is canceled.
Key lock	When the key lock is "ON".	-----	-----	The setting is disabled.
Automatic calibration function	Normally, the zero point of the CO <sub>2</sub> sensor is calibrated every 4 hours (or very 10 minutes for the first hour after switch ON), using the atmosphere as the gas to be calibrated.	The decimal point (period) on the digital CO <sub>2</sub> density indicator blinks.	-----	-----
CO <sub>2</sub> gas cylinder empty	If the CO <sub>2</sub> density does not increase when the gas valve is opened.	E01 is displayed alternately with the temperature on the temperature indicator.	Intermittent tone	Remote alarm
Gas line changeover	When the gas supply line is switched. (only when MCO-80GC is installed)	E01 is displayed alternately with the temperature on the digital temperature indicator. Gas supply line indicator blinks.	Intermittent tone	Gas supply line is altered. Remote alarm
Chamber temperature sensor abnormality	If the temperature sensor is disconnected.	E05 is displayed alternately with the temperature on the digital temperature indicator.	Intermittent tone	Heater OFF Remote alarm
	If the temperature sensor is short circuited.	E06 is displayed alternately with the temperature on the digital temperature indicator.		
Sensor box temperature sensor abnormality	If the sensor box temperature sensor is disconnected.	E07 is displayed alternately with the temperature on the digital temperature indicator.	Intermittent tone	CO <sub>2</sub> valve close. Remote alarm
	If the sensor box temperature sensor is short circuited.	E08 is displayed alternately with the temperature on the digital temperature indicator.		
Ambient temperature sensor abnormality	If the ambient temperature sensor is disconnected.	E09 is displayed alternately with the temperature on the digital temperature indicator.	Intermittent tone	Remote alarm
	If the ambient temperature sensor is short circuited.	E10 is displayed alternately with the temperature on the digital temperature indicator.		
CO <sub>2</sub> sensor abnormality	If the output voltage of the CO <sub>2</sub> sensor is abnormal.	E11 is displayed alternately with the temperature on the digital temperature indicator.	Intermittent tone	CO <sub>2</sub> valve close. Remote alarm
Main heater abnormality	If the upper limit alarm temperature alarm operates, or if the main heater or the main heater relay is open circuit.	E12 is displayed alternately with the temperature on the digital temperature indicator.	Intermittent tone	Remote alarm
Bottom heater abnormality	If the bottom heater or the bottom heater relay goes open circuit.	E13 is displayed alternately with the temperature on the digital temperature indicator.	Intermittent tone	Remote alarm
Door heater abnormality	If the door heater or the door heater relay goes open circuit.	E14 is displayed alternately with the temperature on the digital temperature indicator.	Intermittent tone	Remote alarm
Sensor box heater abnormality	If the sensor box heater or the sensor box relay goes open circuit.	E15 is displayed alternately with the temperature on the digital temperature indicator.	Intermittent tone	Remote alarm
Disconnection of sensor for each heater	If the relay of main heater, bottom heater or sensor box heater goes open circuit.	E16 is displayed alternately with the temperature on the digital temperature indicator.	Intermittent tone	Remote alarm
Air pump (for sample air or auto-zero) failure	If the air pump (sampling or auto zero) does not operate, or if there is something wrong in the gas piping.	E17 is displayed alternately with the temperature on the digital temperature indicator.	Intermittent tone	Remote alarm
Low humidifying water	If the water in the pan is about 5 liters.	RH PAN lamp blinks.	-----	Bottom heater OFF

# ALARMS & SAFETY FUNCTIONS

Alarm & Safety	Situation	Indication	Buzzer	Safety operation
UV lamp failure	[when MCO-80UVS is installed] When the UV lamp does not light in 30 sec after the door is closed.	E18 is displayed alternately with the temperature on the digital temperature indicator.	Intermittent tone	Remote alarm
Flange heater abnormality	If the flange heater or the flange heater relay goes open circuit.	E19 is displayed alternately with the temperature on the digital temperature indicator.	Intermittent tone	Remote alarm
Glass frame heater abnormality	If the glass frame heater or the glass frame heater relay goes open circuit.	E20 is displayed alternately with the temperature on the digital temperature indicator.	Intermittent tone	Remote alarm
Water sensor (level) abnormality	If the water sensor of water level goes open circuit or short circuit.	E21 is displayed alternately with the temperature on the digital temperature indicator.	Intermittent tone	Bottom heater OFF Remote alarm
Water sensor (standard temperature) abnormality	If the water sensor of standard temperature goes open circuit or short circuit.	E22 is displayed alternately with the temperature on the digital temperature indicator.	Intermittent tone	Bottom heater OFF Remote alarm
Door alarm	When the outer door is open.	Door lamp lights.	-----	Fan stops.

- The alarm can be canceled by pressing the alarm buzzer stop key (BUZZER), but the remote alarm cannot be silenced.
- Once upper limit temperature alarm is activated, the over heat lamp still remains blink even after the temperature is resumed. Press the upper limit alarm reset key (RESET) to cancel the lighting.
- E01 is cleared automatically when the gas is connected correctly and the buzzer is silenced with the alarm buzzer stop key (BUZZER). When MCO-80GC is installed, press the alarm buzzer stop key (BUZZER) to silence the alarm after changeover of gas supply line.
- If one of E05 to E17 (except for E12, E13, and E14) is displayed, consult with a Sanyo sales representative or agent.

# SETTING OF ALARM RESUME TIME

The alarm buzzer is silenced by pressing alarm buzzer stop key (BUZZER) on the control panel during alarm condition.

The buzzer will be activated again after certain suspension if the alarm condition is continued. The suspension time can be set by following the procedure shown in the table below.

The example in the table is based on the assumption that the desired duration is 20 minutes.

**Note:** The duration is set in 30 minutes at the factory.

**Table Changing procedure for alarm resume time (Ex: change from 30 minutes to 20 minutes)**

	Description of operation	Key operated	Indication after operation
1		----	The current chamber temperature is displayed.
2	Press calibration key for 5 seconds.		The left digit is flashed.
3	Set the figure to F25 with the digit shift key and numerical value shift key.	▶▶	The settable digit is shifted.
		▲	When pressed, the figure of settable digit changes.
4	Press enter key.	ENT	The current setting is displayed. The middle digit is flashed.
5	Set the figure to 020 with the numerical value shift key.	▲	When pressed, the figure of settable digit changes.
6	Press enter key.	ENT	The setting is memorized and the current chamber temperature is displayed.

- The settable alarm resume time are 0, 10, 20, 30, 40, 50, or 60 minutes (The setting is 000, 010, 020, 030, 040, or 060 respectively). The buzzer would not reset if the resume time is set in 000.
- The set mode returns to the temperature display mode automatically when 90 seconds has passed without any key operation. In this case, any setting before pressing enter key is not memorized.

## WARNING

**Do not use calibration key (CAL)** on the control panel in normal use. Pressing this key leads the calibration mode. Wrong key operation affects the basic performance. Never touch any other keys on the control panel in the event of pressing calibration key (CAL) accidentally. After about 90 seconds, the unit returns to chamber temperature display mode automatically.

## Operation after power failure

The set value is memorized by nonvolatile memory. Accordingly, the incubator resumes the operation with setting before power failure.

# ROUTINE MAINTENANCE

## **⚠️ WARNING**

Always disconnect the power supply to the unit prior to any repair or maintenance of the unit in order to prevent electric shock or injury.

The water level sensor periodically generates heat at around 70 °C that may be cause of burn injury.

Ensure you do not inhale or consume medication or aerosols from around the unit at the time of maintenance. These may be harmful to your health.

## **⚠️ CAUTION**

Always put on dry gloves to protect hands at the time of maintenance. Failure to use gloves may result in cuts or abrasions from any sharp edges or corners.

Do not put too much force for cleaning of the water level sensor, wipe it off lightly.

## Sterilizing of chamber and attachments

When the chamber of the unit is contaminated, the chamber and internal attachments should be cleaned and sterilized as follows.

### **Note:**

Take care not to damage the UV lamp (when an optional UV system kit MCO-80UVS is installed) or water level sensor at the time of removal or replacement of attachments.

Do not clean the inside of the unit with a solution of sodium hypochlorite or other halogen-based solution because this may cause corrosion of metal surfaces.

1. Turn off power switch of the unit.
2. Open the outer door, and take out all trays and tray supports from the chamber. See Fig.1.
3. Remove screws of the ceiling panel consisting of two panels and remove them. See Fig.2.
4. Lift the bottom lid from the pins to remove the bottom lid. See Fig.3.

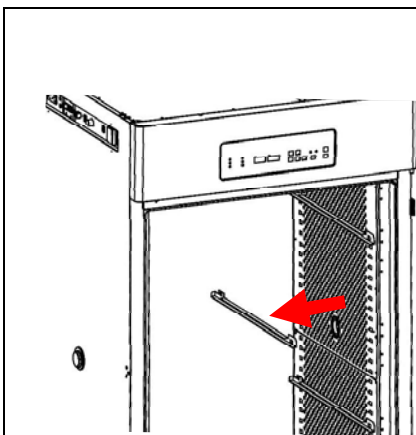

Fig. 1

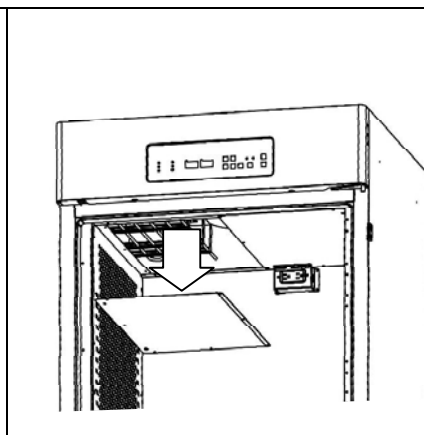

Fig. 2

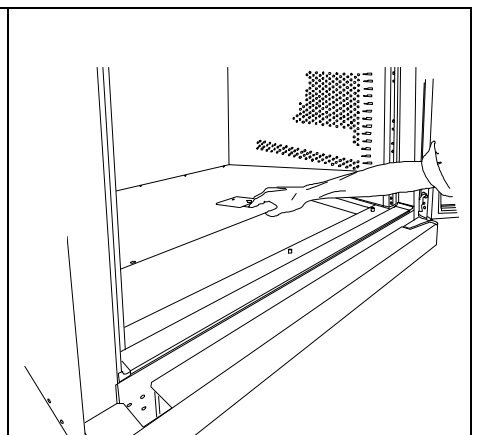

Fig. 3

# ROUTINE MAINTENANCE

5. Remove screws of the side ducts to dismount four side ducts. See Fig.4.

6. Remove screws at the lower both side to remove the front panel lower cover (Fig.5). To drain all humidifying water, open the drain valve. Then water drain away through the drain outlet (Fig.6). Wipe off remained water with a dry gauze.

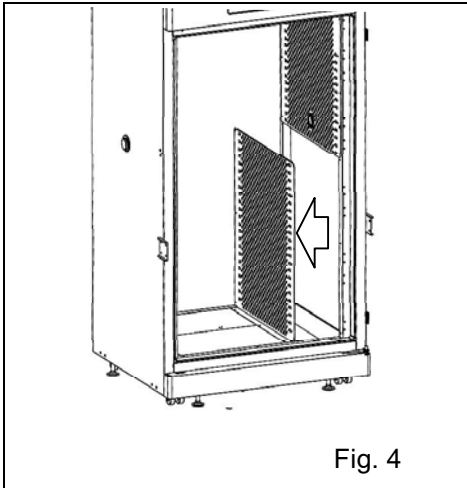

Fig. 4

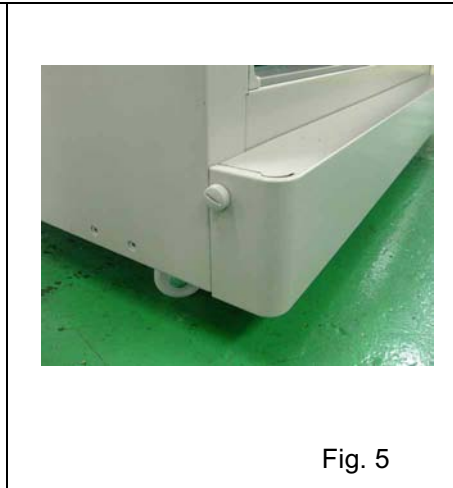

Fig. 5

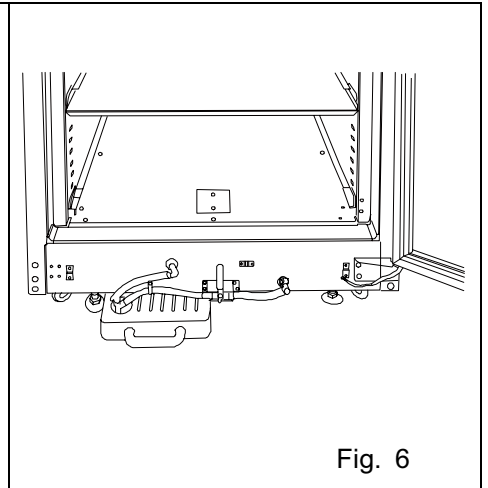

Fig. 6

7. Clean all the attachments with neutral detergent and then rinse away the detergent with distilled water.

8. Wipe the attachments with a gauze containing alcohol for sterilization and then wipe off with a dry gauze.

9. Wipe the inside wall of the chamber and humidifying pan with a gauze containing alcohol for sterilization and then wipe off with a dry gauze.

10. Wipe the water level sensor with a gauze containing alcohol for sterilization and then wipe off with a dry gauze. Care should be taken not to stress the water level sensor.

11. Replace all attachments in the chamber with the reversed order mentioned above.

12. When operating in the normal mode or the high humidity mode, fill the humidifying pan with sterile distilled water. See page 29. If operating in the no humidifying mode, do not supply any water into the humidifying pan.

**Note:**

- As shown in the figure, set the shelf with the edge bent downwardly positioned at the front. Improper setting cause tilted or unstable condition.

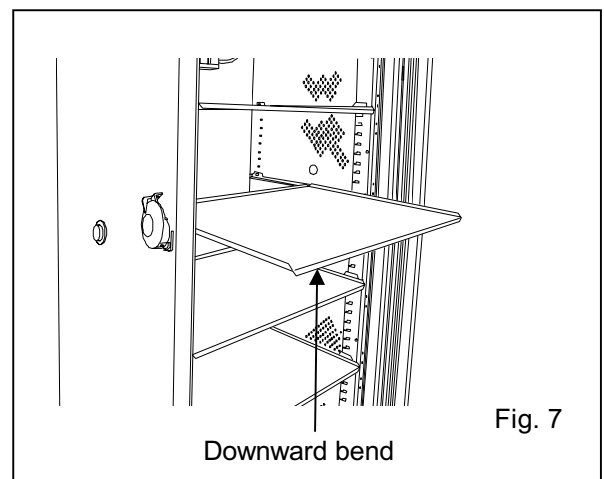

Fig. 7

# ROUTINE MAINTENANCE

## Filling the humidifying pan

To fill the humidifying pan, do the following:

1. Open the outer door and remove the lowest shelf. See Fig.1.
2. Remove a screw in front side and rotate the cover to open the water supply inlet. See Fig.2.
3. When there is no water in the humidifying pan (for example, first time to operate), add approximately 20 L of preheated sterile distilled water at 37 °C. When lighting RH PAN lamp, add approximately 15 L of preheated sterile distilled water at 37 °C. See Fig.3.
4. Make sure the water level alarm lamp (RH PAN) on the control panel does not light.
5. Rotate back the water supply inlet cover and tighten the removed screw.
6. Put the lowest shelf back in place and close the outer door.

**Note:**

- The sterile water filled in the humidifying pan should be pre-heated at 37°C. Cold water lowers the chamber temperature and humidity.

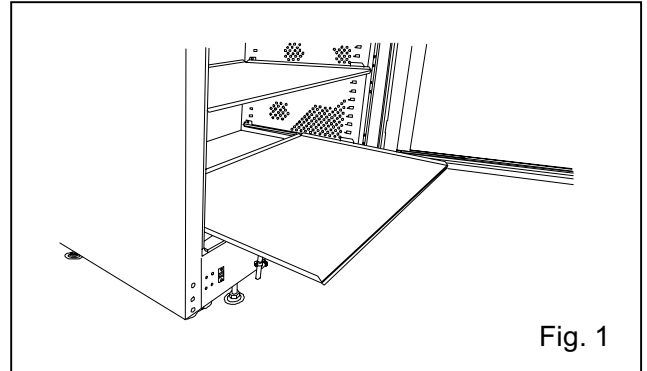

Fig. 1

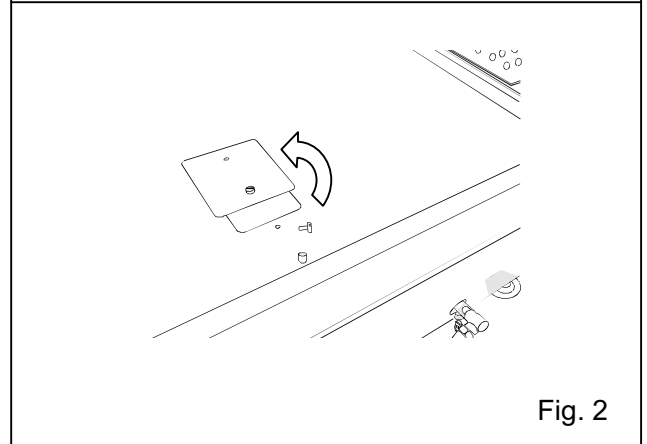

Fig. 2

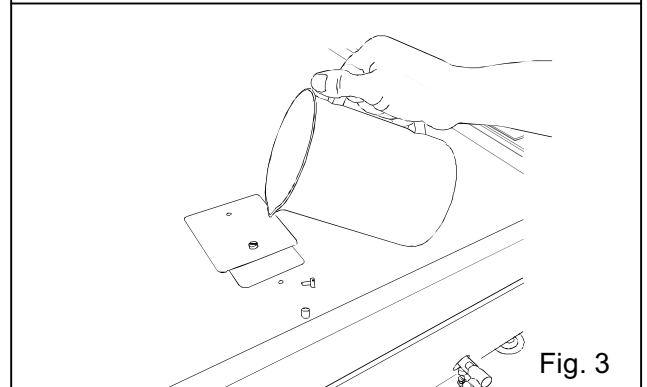

Fig. 3

# CALIBRATION

## Temperature calibration

1. Press the calibration key (CAL) for approximately 5 seconds.
2. The third digit of the temperature indicator flashes, and the CO<sub>2</sub> density indicator goes out.
3. Set the present correct temperature with the digit shift key (▶▶) and numerical value shift key (▲), then press the enter key (ENT).
4. The unit automatically reverts to the display mode.

[Example]

If the displayed chamber temperature is 37.0°C (set value) and the actual temperature is 36.8°C.

1. Press the calibration key (CAL) for about 5 seconds.
2. The “3” on the temperature indicator flashes, and the CO<sub>2</sub> density indicator goes out.
3. Adjust the set value to the actual value of 36.8°C with the digit shift key (▶▶) and numerical value shift key (▲), then press enter key (ENT).
4. The unit automatically reverts to the display mode.

### Note:

It is important to accurately measure the temperature inside the unit when performing temperature calibration. Particularly, the temperature gauge used must have an accuracy of 0.5 Class or better. The temperature must be measured at several points.

The temperature setting must not change by more than  $\pm 1.0^{\circ}\text{C}$  during calibration. If it exceeds this, an error tone is emitted, the input data is ignored, and the unit reverts to the display mode. Consequently, if it is necessary to change the temperature by more than 1.0°C, perform calibration in several stages over a period of time.

## CO<sub>2</sub> calibration

### Span setting

Span setting should be done under stable condition of temperature, humidity, and CO<sub>2</sub> density.

1. Press the calibration key (CAL) for about 5 seconds.
2. The third digit on the temperature indicator flashes, and the CO<sub>2</sub> density indicator goes out.
3. Press the calibration key (CAL) once again.
4. The third digit on the CO<sub>2</sub> density indicator flashes, and the temperature indicator goes out.
5. Set the present correct CO<sub>2</sub> density with the digit shift key (▶▶) and numerical value shift key (▲), then press the enter key (ENT).
6. The unit automatically reverts to the display mode.

### Note:

This calibration is available when the setting of CO<sub>2</sub> density is 2% or more.

[Example]

For an internal CO<sub>2</sub> density of 5.0% (setting) and a measured value of 4.5%.

1. Press the calibration key (CAL) for about 5 seconds.
2. The third digit on the temperature indicator flashes, and the CO<sub>2</sub> density indicator goes out.
3. Press the calibration key (CAL) once again.
4. The third digit on the CO<sub>2</sub> density indicator flashes, and the temperature indicator goes out.
5. Set the present correct CO<sub>2</sub> density (4.5%) with the digit shift key (▶▶) and numerical value shift key (▲), then press the enter key (ENT).
6. The unit automatically reverts to the display mode.

# TROUBLESHOOTING

If the unit malfunctions, check out the following before calling for service.

Malfunction	Check/Remedy
The unit does not operate at all.	<ul style="list-style-type: none"> <li>The unit is not plugged correctly into a power outlet.</li> <li>The circuit breaker at the power source is active or a power failure has occurred.</li> </ul>
The key operation is disable	<ul style="list-style-type: none"> <li>The key lock function is set in ON mode.</li> </ul>
If the alarm function and the buzzer operates	<p>[At the beginning of operation]</p> <ul style="list-style-type: none"> <li>The chamber temperature is not equal to the set value.</li> <li>The chamber CO<sub>2</sub> density is not equal to the set value.               <ol style="list-style-type: none"> <li>The secondary pressure of the pressure regulator is not equal to the set value (0.1MPaG, 1.0kgf/cm<sup>2</sup>G, 14.5psiG).</li> <li>The tube is not connected securely between the pressure regulator and the unit.</li> </ol> </li> </ul> <p>[During operation]</p> <ul style="list-style-type: none"> <li>The upper limit alarm temperature is not set at least 1°C higher than the set chamber temperature.</li> <li>The set temperature value was changed, or the door was left open for a long period. Or a low temperature load was placed inside the unit. In this case, if the unit is left as it is, the alarm will eventually clear itself.</li> <li>The gas tube has slipped off or the gas leaks.</li> <li>The set value of the gas density was changed.</li> <li>The gas cylinder is empty. Check the primary pressure of the CO<sub>2</sub> cylinder once a week. (The primary pressure of less than 3.8MPaG (38kgf/cm<sup>2</sup>G) means a little gas in the cylinder. Replace the cylinder soon.)</li> </ul>
If the chamber temperature is not equal to the set temperature	<ul style="list-style-type: none"> <li>The ambient temperature must always be at least 5°C less than the set temperature.</li> </ul>
If the gas density does not coincide with the set value	<ul style="list-style-type: none"> <li>The secondary pressure is not set to 0.1MPaG (1.0kgf/cm<sup>2</sup>G, 14.5psiG).</li> <li>The gas tube is clogged or chinked.</li> </ul>
If the chamber humidity does not rise	<ul style="list-style-type: none"> <li>The humidifying pan is not filled with sterile distilled water. (Always use sterile distilled water.)</li> <li>The no humidifying mode is set.</li> </ul>
If the CO <sub>2</sub> consumption is too much	<ul style="list-style-type: none"> <li>The door is opened frequently.</li> <li>There is any gas leakage at the connection or pin hole on the tube. It is recommended to replace the tube once a year.</li> <li>A access port is opened.</li> </ul>
If normal cultivation cannot be done and chamber gas density is suspect	<ul style="list-style-type: none"> <li>The environment around the unit is not normal. The source of the contaminated gas is nearby.</li> <li>The unit is installed in an enclosed space.</li> </ul>
If it takes much time to recover the gas density	<ul style="list-style-type: none"> <li>HEPA filter is provided in the gas piping. If it takes much time to recover the gas density even though the gas pressure is normal, it may be that dust on the HEPA filter prevents the gas flow. Consult the Sanyo dealer or agent.</li> </ul>
If CO <sub>2</sub> gas is not injected	<ul style="list-style-type: none"> <li>The CO<sub>2</sub> injection system is ON-OFF controlled and injects gas intermittently when the set density is close. Injection might stop for 15 sec but it is not abnormal.</li> </ul>

# TROUBLESHOOTING

---

**Note:**

If the malfunction is not eliminated after checking the above items, or the malfunction is not shown in the above table, contact Sanyo sales representative or agent.

# DISPOSAL OF UNIT

## **WARNING**

If the unit is to be stored unused in an unsupervised area for an extended period **ensure that children do not have access and doors cannot be closed completely.**

**The disposal of the unit should be accomplished by appropriate personnel. Always remove doors to prevent accidents such as suffocation.**

# DISPOSAL OF UNIT

**Note:**

This symbol mark and recycle system are applied only to EU countries and not applied to the countries in the other area of the world.

## Waste Electrical and Electronic Equipment (WEEE) Directive-2002/96/EC

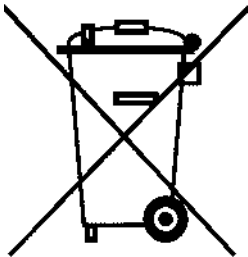

**(English)**

Your SANYO product is designed and manufactured with high quality materials and components which can be recycled and reused.

This symbol means that electrical and electronic equipment, at their end-of-life, should be disposed of separately from your household waste.

Please dispose of this equipment at your local community waste collection/recycling centre.

In the European Union there are separate collection systems for used electrical and electronic products.

Please help us to conserve the environment we live in!

**(German)**

Ihr SANYO Produkt wurde entworfen und hergestellt mit qualitativ hochwertigen Materialien und Komponenten, die recycelt und wiederverwendet werden können.

Dieses Symbol bedeutet, daß elektrische und elektronische Geräte am Ende ihrer Nutzungsdauer von Hausmüll getrennt entsorgt werden sollen.

Bitte entsorgen Sie dieses Gerät bei Ihrer örtlichen kommunalen Sammelstelle oder im Recycling Centre.

In der Europäischen Union gibt es unterschiedliche Sammelsysteme für Elektrik- und Elektronikgeräte.

Helfen Sie uns bitte, die Umwelt zu erhalten, in der wir leben!

# DISPOSAL OF UNIT

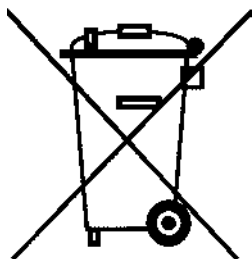

## (French)

Votre produit Sanyo est conçu et fabriqué avec des matériaux et des composants de qualité supérieure qui peuvent être recyclés et réutilisés.

Ce symbole signifie que les équipements électriques et électroniques en fin de vie doivent être éliminés séparément des ordures ménagères.

Nous vous prions donc de confier cet équipement à votre centre local de collecte/recyclage. Dans l'Union Européenne, il existe des systèmes sélectifs de collecte pour les produits électriques et électroniques usagés.

Aidez-nous à conserver l'environnement dans lequel nous vivons !

Les machines ou appareils électriques et électroniques contiennent fréquemment des matières qui, si elles sont traitées ou éliminées de manière inappropriée, peuvent s'avérer potentiellement dangereuses pour la santé humaine et pour l'environnement.

Cependant, ces matières sont nécessaires au bon fonctionnement de votre appareil ou de votre machine. Pour cette raison, il vous est demandé de ne pas vous débarrasser de votre appareil ou machine usagé avec vos ordures ménagères.

## (Spanish)

Los productos SANYO están diseñados y fabricados con materiales y componentes de alta calidad, que pueden ser reciclados y reutilizados.

Este símbolo significa que el equipo eléctrico y electrónico, al final de su ciclo de vida, no se debe desechar con el resto de residuos domésticos.

Por favor, deposite su viejo "televisor" en el punto de recogida de residuos o contacte con su administración local.

En la Unión Europea existen sistemas de recogida específicos para residuos de aparatos eléctricos y electrónicos.

Por favor, ayúdenos a conservar el medio ambiente!

# DISPOSAL OF UNIT

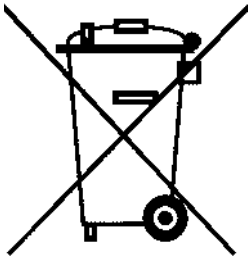

## **(Portuguese)**

O seu produto SANYO foi concebido e produzido com materiais e componentes de alta qualidade que podem ser reciclados e reutilizados.

Este símbolo significa que o equipamento eléctrico e electrónico no final da sua vida útil deverá ser descartado separadamente do seu lixo doméstico.

Por favor, entregue este equipamento no seu ponto local de recolha/reciclagem.

Na União Europeia existem sistemas de recolha separados para produtos eléctricos e electrónicos usados.

Por favor, ajude-nos a conservar o ambiente em que vivemos!

## **(Italian)**

Il vostro prodotto SANYO è stato costruito da materiali e componenti di alta qualità, che sono riutilizzabili o riciclabili.

Prodotti elettrici ed elettronici portando questo simbolo alla fine dell'uso devono essere smaltiti separatamente dai rifiuti casalinghi.

Vi preghiamo di smaltire questo apparecchio al deposito comunale.

Nell'Unione Europea esistono sistemi di raccolta differenziata per prodotti elettrici ed elettronici.

Aiutateci a conservare l'ambiente in cui viviamo!

# DISPOSAL OF UNIT

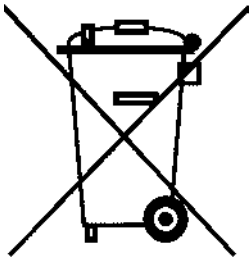

## **(Dutch)**

Sanyo producten zijn ontwikkeld en gefabriceerd uit eerste kwaliteit materialen, de onderdelen kunnen worden gerecycled en weer worden gebruikt.

Het symbool betekent dat de elektrische en elektronische onderdelen wanneer deze vernietigd gaan worden, dit separaat gebeurt van het normale huisafval.

Zorg ervoor dat het verwijderen van de apparatuur bij de lokaal erkende instanties gaat gebeuren. In de Europese Unie wordt de gebruikte elektrische en elektronische apparatuur bij de daarvoor wettelijke instanties aangeboden.

Alstublieft help allen mee om het milieu te beschermen.

## **(Swedish)**

Din SANYO produkt är designad och tillverkad av material och komponenter med hög kvalitet som kan återvinnas och återanvändas.

Denna symbol betyder att elektriska och elektroniska produkter, efter slutanvändande, skall sorteras och lämnas separat från Ditt hushållsavfall.

Vänligen, lämna denna produkt hos Din lokala mottagningstation för avfall/återvinningsstation.

Inom den Europeiska Unionen finns det separata återvinningssystem för begagnade elektriska och elektroniska produkter.

Vänligen, hjälp oss att bevara miljön vi lever i!

# AUTOMATIC CO<sub>2</sub> CYLINDER CHANGEOVER

Automatic CO<sub>2</sub> cylinder changeover system (MCO-80GC) is available as an optional accessory. This system switches the gas supply line when one CO<sub>2</sub> gas cylinder is empty.

**Note:** The installation of MCO-80GC should be implemented by a qualified service personnel.

After attachment of MCO-80GC, do the following:

1. Connect a CO<sub>2</sub> gas pipe to port A and B respectively. A connecting port for CO<sub>2</sub> gas pipe is located on the upper back of the unit. (See page 9).
2. Connect a CO<sub>2</sub> gas cylinder provided with a gas pressure regulator to each gas pipe. See page 16, for the connection of the gas cylinder.
3. Open the valve of each gas cylinder.
4. Check that the CO<sub>2</sub> gas supply line indicator on the control panel is lit by pressing the switching key.
5. Select a CO<sub>2</sub> gas supply line (A or B).
6. When one cylinder is empty, the indicator is flashed, buzzer sounds, and "E01" and current chamber temperature are displayed alternately on the control panel while the gas supply line is switched to other one. To silence the buzzer, press the buzzer stop key (BUZZER).
7. Replace the empty CO<sub>2</sub> gas cylinder.

**Note:** Exercise caution when handling empty CO<sub>2</sub> gas cylinders as some gas can be still be left in the cylinder.

This system MCO-80GC detects that no more CO<sub>2</sub> gas exists in a cylinder when the CO<sub>2</sub> density in the chamber is not increased for a while after opening of CO<sub>2</sub> gas valve in the unit and switches the gas supply line. The switching of supply line can be caused by some other reasons; blocking or restricting of gas tube, reduction of CO<sub>2</sub> gas pressure, or improper opening of CO<sub>2</sub> gas cylinder, in spite of gas quantity in the cylinder. Therefore, always check the gas quantity in the cylinder prior to disconnection.

# SPECIFICATIONS

Name	CO <sub>2</sub> Incubator
Model	MCO-80IC
External dimensions	W986 x D853 x H2,040 (without caster; H1,975) (mm)
Internal dimensions	W806 x D693x H1,524 (mm)
Interior volume	851 L
Exterior	Painted steel
Interior	Stainless steel containing copper
Outer door	Double glass with door heater Outer door latch
Tray	5 trays made of stainless steel containing copper W776 x D659 x H10 (mm), Maximum load; 30 kg/tray
Access port	Inner diameter; 40 mm, Two locations, each on both sides
Insulation	Rigid polyurethane foamed-in place
Heater	Main heater: 600 W, Humidifying pan heater: 211 W, Door frame heater: 125 W, Flange heater: 250 W, Glass heater: 150 W
Humidifying system	Normal mode: Natural evaporation with humidifying water High humidity mode: Heated evaporation with humidifying water
Temperature controller	PID control system
Temperature display	Digital display
CO <sub>2</sub> controller	PID control system
CO <sub>2</sub> density display	Digital display
Air circulation	Fan assisted
Air filter	0.3 $\mu$ m, Efficiency; 99.97% or more
Water level sensor	Thermal type
Alarm	High/Low temperature alarm, CO <sub>2</sub> density alarm, Upper limit temperature alarm Door alarm
Remote alarm contact	Allowable contact capacity: DC 30 V, 2 A
CO <sub>2</sub> inlet connection	4 to 6 mm diameter tube
CO <sub>2</sub> inlet pressure	0.1 MPaG (1.0 kgf/cm <sup>2</sup> G, 14.5 psiG)
Accessories	5 trays, 5 sets of tray support, 1 gas tube, 2 tube bands, 1 drain tank (6.5 L)
Power source	Single phase, 110-120 V, 60 Hz
Inside power outlet	Two sockets (Up to 3 A in total) Use condition: Inner temperature below 40 °C and humidity below 50%R.H.
Outer power outlet	Two sockets (Up to 1 A in total)
Weight	275 kg
Optional accessory	Automatic CO <sub>2</sub> cylinder changeover system (MCO-80GC) Extra tray (MCO-80ST) Same tray as the attached one including 2 tray supports Roller bottle mounting kit (MCO-80RBS) Small doors mounting kit (MCO-80ID), UV system kit (MCO-80UVS), Automated water supply system kit (MCO-80AS), Lightproof film (MCO-80FM), mA Analog output (MCO-420MA), Communication interface (MTR-2000, MTR-480C)

**Note:** Design or specifications will be subject to change without notice.

# PERFORMANCE

Temperature control range	Ambient temperature +5°C to 50°C (ambient temperature; 20°C to 35°C)
Temperature distribution	± 0.5°C* (ambient temperature; 25°C, setting; 37°C, 5%, no load)
Temperature variation	± 0.1°C (ambient temperature; 25°C, setting; 37°C, 5%, no load)
CO <sub>2</sub> control range	0 to 20%
CO <sub>2</sub> variation	± 0.15% (ambient temperature; 25°C, setting; 37°C, 5%, no load)
Chamber humidity	Normal mode; Over 80% R.H. High humidity mode; Over 90% R.H.
Maximum heat emission	6307 kJ/h
Usable environment condition	Temperature; 20°C to 35°C, Humidity; equal or less than 80% R.H. (The designed performance may not be obtained when the ambient temperature is less than 20°C)
Noise level	33 dB (A scale)
Maximum power consumption	1840 W
Total maximum current	110-120 V, 60 Hz
	16.0 A

**Note:** The unit with CE mark complies with EC directives 89/336/EEC, 93/68/EEC and 73/23/EEC.

\* It is based on our measuring method.

## CAUTION

Please fill in this form before servicing.  
Hand over this form to the service engineer to keep for his and your safety.

### Safety check sheet

1. Incubator contents :
- |                                |                              |                             |
|--------------------------------|------------------------------|-----------------------------|
| Risk of infection:             | <input type="checkbox"/> Yes | <input type="checkbox"/> No |
| Risk of toxicity:              | <input type="checkbox"/> Yes | <input type="checkbox"/> No |
| Risk from radioactive sources: | <input type="checkbox"/> Yes | <input type="checkbox"/> No |

(List all potentially hazardous materials that have been stored in this unit.)

Notes :

2. Contamination of the unit

- |                  |                              |                             |
|------------------|------------------------------|-----------------------------|
| Unit interior    | <input type="checkbox"/> Yes | <input type="checkbox"/> No |
| No contamination | <input type="checkbox"/> Yes | <input type="checkbox"/> No |
| Decontaminated   | <input type="checkbox"/> Yes | <input type="checkbox"/> No |
| Contaminated     | <input type="checkbox"/> Yes | <input type="checkbox"/> No |
| Others:          |                              |                             |

3. Instructions for safe repair/maintenance of the unit

- a) The unit is safe to work on Yes No
- b) There is some danger (see below) Yes No

Procedure to be adhered to in order to reduce safety risk indicated in b) below.

Date :

Signature :

Address, Division :

Telephone :

Product name :  
CO<sub>2</sub> incubator

Model :  
MCO-801C

Serial number :

Date of Installation :

Please decontaminate the unit yourself before calling the service engineer.

**SANYO**