

High-pressure Steam Sterilizer

## Labo Autoclave

Model **MLS-3751**

Nos. **MLS-3781**

Thank you for purchasing a Sanyo Autoclave.

- Please read this instruction manual carefully before using the product.  
After reading this manual, store it in a readily accessible place along with the warranty card.
- Please pay particular attention to the “ Safety Precautions ” section on page 1 to 6.



## Contents

Page

**Safety Precautions** . . . . . 1 ~ 6

**Precautions in Use** . . . . . 7

**Before Using the Product** . . . . . 8

**Names and Functions of Part** . . . . . 9 ~ 10

**Explanation of Label** . . . . . 11

**Sterilization Objects** . . . . . 12 ~ 13

### How to Use

• Basic operating procedure . . . . . 14 ~ 22

• For continuous use . . . . . 22

• To stop the operation . . . . . 23

• For timer operation . . . . . 23

**On Power Failure** . . . . . 24

**On Voice Guide** . . . . . 25

**Maintenance** . . . . . 26



**Troubleshooting** . . . . . 27 ~ 28

**Specifications** . . . . . 29









# Safety Precautions

These precautions must be observed without fail.



- Read these “ Safety Precautions ” carefully before use so as to use the product properly.
- Be sure to observe the precautions without fail as they are intended to ensure the safe use of the product, protect you and other people against hazards, and prevent loss of and damage to property.  
The indications and meanings of each category of precaution are as shown below.
- The possible consequences due to inobservance of these precautionary indications or inappropriate operation of the product are classified into the 3 categories as follows.

 <b>DANGER</b> : This warns of actions that will cause death or serious injury to the operator or other persons.
 <b>WARNING</b> : This warns of actions that could possibly cause death or serious injury to the operator or other persons.
 <b>CAUTION</b> : This warns of actions that are likely to cause injury to the operator or other persons or loss of or damage to the property.

- The symbols appearing in the text mean the following.

 This symbol denotes a prohibited action that must not be performed.	 General prohibition	 Disassembly prohibited	 Touching with wet hands prohibited
	 Contact with water prohibited		
 This symbol denotes a compulsory action that must be performed without fail.	 You must do this.	 Grounding wire must be connected.	

- The labels appearing in the text mean the following.

 denotes a caution to be observe.	 This part is hot and may burn.
--	--

## DANGER

**Never introduce inflammables in the product.**



Do not put the following substances specified in Annex 1 of the Occupational Safety and Health Act Enforcement Ordinance into or near the product.

- Explosive substances
- Ignitable substances
- Oxidizing substances
- Flammable substances
- Combustible substances

Failure to observe this warning may result in injury, fire or trouble with the product by possible explosion.

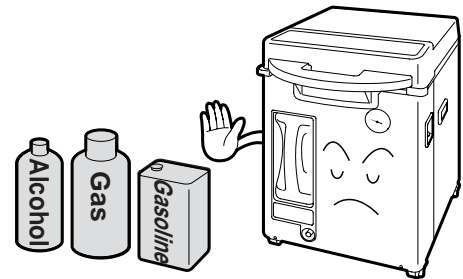

## WARNING

**Do not put anything that corrodes stainless steel inside the product.**



Do not put culture mediums that corrodes stainless steel inside the product.

Failure to observe this warning may result in injury, fire or trouble with the product by possible explosion.

**Check the cover packings.**



Sterilization of animal oil and fat (e.g., waste generated after BSE inspection) causes premature wear, cracking or breakage of the cover packings. If the product is used with defective packings, steam may escape and cause burns or other accidents.



# WARNING

**Ground the product without fail.**

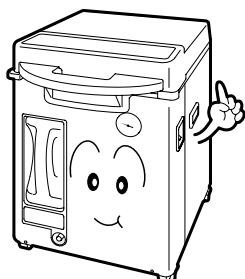

Ground without fail!

Make sure that the product has been properly grounded. Be sure to connect one end of grounding line to the ground and the other end to the grounding terminal.

Failure to observe this warning may result in electric shock.

**Do not extend the power cord.**

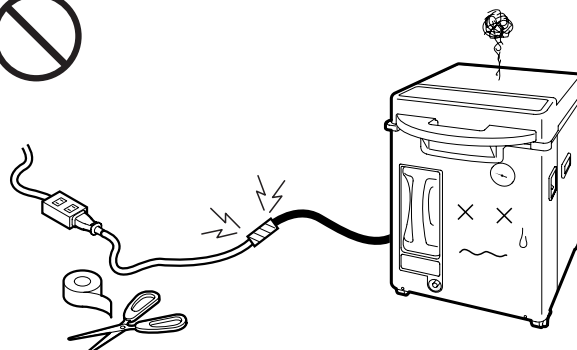

Do not connect the power cord or plug to an extension cord.

Failure to observe this warning may result in electric shock or fire.

**In the event of trouble, stop operation and turn OFF the power.**

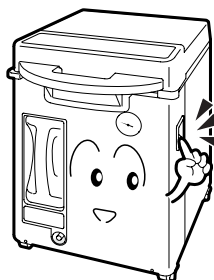

Set my power switch to OFF.

Should trouble (burning smell, etc.) occur, set the power switch to the OFF position, shut down the main power, and contact the dealer from whom you purchased the product.

Continuing to operate the product in anything but proper working order may result in electric shock or fire.

**Do not modify the product.**

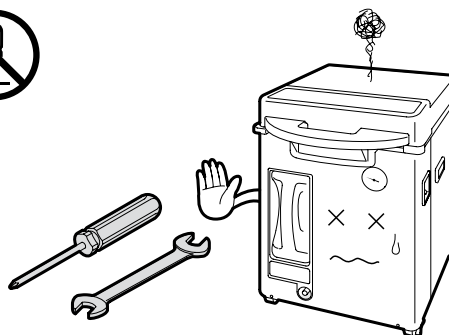

The product should never be disassembled or repaired by any other person than a qualified service engineer.

Failure to observe this warning may result in fire, malfunction or injury.

**Check the product for sterilization performance.**

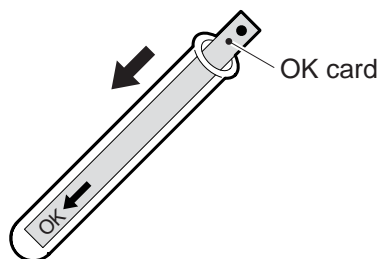

The sterilization performance will vary depending on such factors as the type and volume of objects to be sterilized, the arrangement of objects and the type of container. Therefore, use a sterilization indicator such as an "OK card" for checking the performance.

Failure to observe this warning may result in accident or incomplete sterilization.

**Do not open the drain valve during operation.**

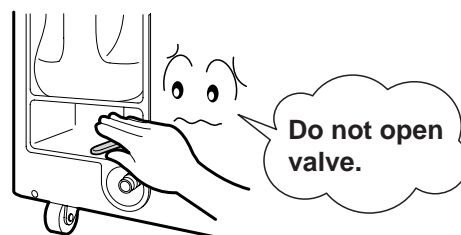

Do not open valve.

Before draining off heating water, open the cover for at least 2 hours after the end of operation.

Failure to observe this warning may cause hot water to gush out, resulting in scald or accident.

(Heating water is water that is poured into the chamber to help the heater in the chamber generate steam for sterilization.)

# Safety Precautions



## WARNING

**Do not sterilize objects in a steam impermeable container or bag.**

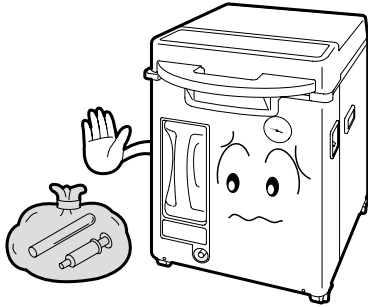

Failure to observe this warning may result in accident or incomplete sterilization.

**Do not block the holes or temperature sensor in the chamber with objects.**

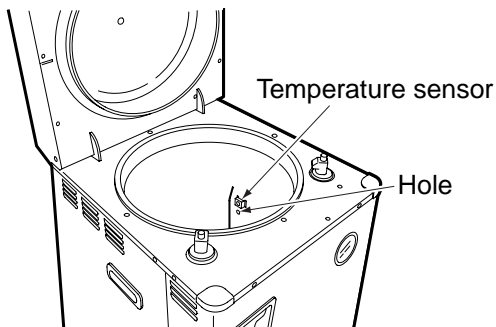

Failure to observe this warning may destabilize control of the product or result in incomplete sterilization.

**When sterilizing only containers such as beakers, flasks and test tubes, place them with their openings facing downward or lay them on their sides.**

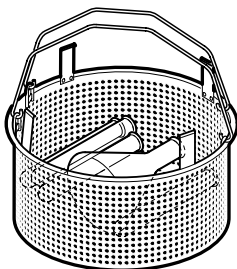

If the containers are placed with their openings facing upward, it is hard for air to sufficiently escape from the container and for steam to sufficiently penetrate inside, thus resulting in incomplete sterilization.

**Do not seal the object container tightly.**

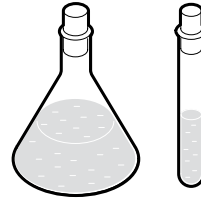

**Use a porous cap or loosen the cover sufficiently.** Failure to observe this warning may result in accident or incomplete sterilization.

**Do not place objects on the temperature sensor in the chamber.**

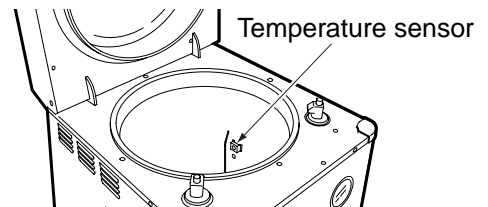

Failure to observe this warning may destabilize control of the product or result in incomplete sterilization.

**When sterilizing waste, pour about 300ml of water into the sterilization bag and sterilize the waste with the bag open.**

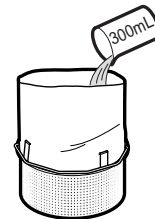

Sterilizing without water in the bag or with the bag closed may result in incomplete sterilization.

**When using the sterilization bag, be sure to put it in the stainless steel basket included with the product and set it in the chamber for sterilization.**

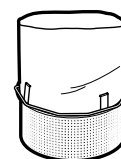

If the sterilization bag is put directly in the chamber, it may block the temperature sensor or it may be pinched between the chamber opening and the cover packing, resulting in trouble with the product.



# CAUTION

**Connect power cord of the product to its own dedicated outlet.**

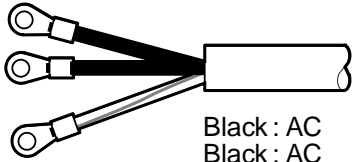

Black : AC  
Black : AC  
Yellow/Green : Grounding wire

Connect the power cord to a dedicated outlet as shown below.

<MLS-3751>: Single phase, 100V AC, 20A or higher  
<MLS-3781>: Single phase, 200V AC, 20A or higher

Failure to observe this caution may result in ignition or malfunctioning.

**Use care not to scald yourself when taking out the sterilized objects at the end of operation.**

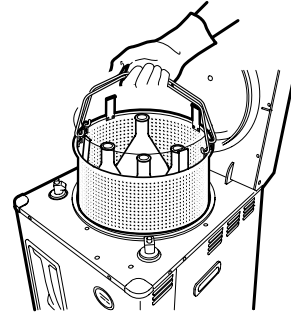

Be sure to wear thermally insulated leather gloves. Note that it takes time until liquid is cooled down.

Handling a sterilized object with bare hands immediately after the end of operation may result in burns.

**Before performing maintenance, set the power switch to the OFF position.**

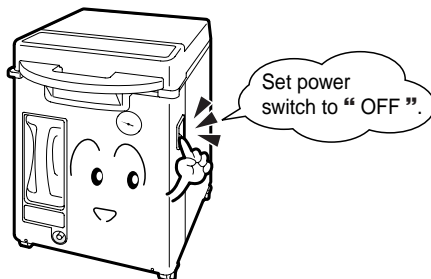

Set power switch to "OFF".

Set the power switch to "OFF" and sufficiently cool the product before performing maintenance.

Failure to observe this warning may result in electric shock or burns.

**Do not touch the power switch with wet hands.**

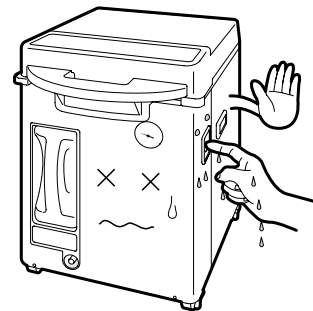

Failure to observe this caution may result in electric shock.

**Nothing should be placed on the power cord.**

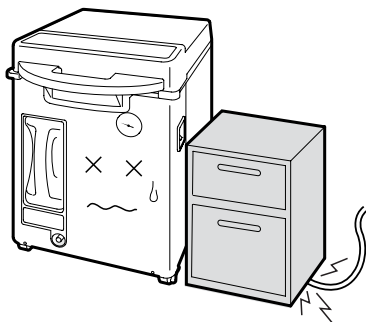

Failure to observe this caution may overheat the power cord, resulting in fire.

**Do not use staples or nails to anchor the power cord.**

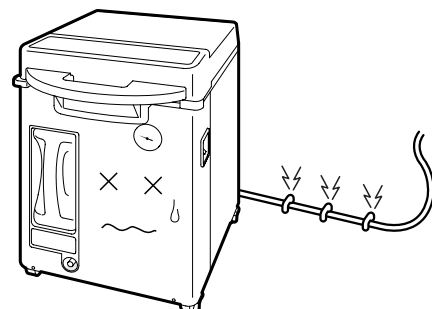

Failure to observe this caution may overheat the power cord, resulting in fire.

# Safety Precautions



## CAUTION

**Be careful about the position of the exhaust hose insertion holes.**

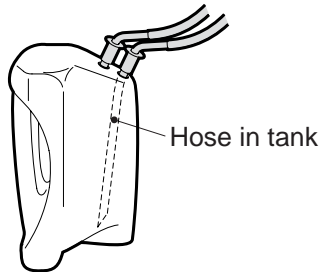

**Be sure to insert the hose in the tank into the holes at the back inside the exhaust tank.**  
Failure to observe this caution may cause large steam leaks from the tank on the rear side.

**When using the exhaust tank attached to the product, insert the exhaust hose packings securely in the holes of the exhaust tank.**



**Be sure to use the exhaust tank attached to the product.**  
If the packings of the exhaust hose have not been inserted sufficiently, steam may escape and result in burns.

**Insert the hose securely.**

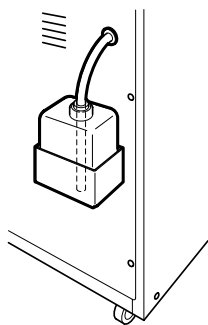

**Be sure to insert the hose down to the bottom of the exhaust tank on the rear side.**  
Incomplete hose insertion may cause steam or hot water to spill over the tank.

**Do not allow children to use or play with the product.**



Failure to observe this caution may result in burns, electric shock or injury.

**Keep your head away when opening the cover at the end of operation.**



**Since high-temperature steam will escape when the cover is opened, wait until the steam dissipates. During this time, keep your head away from the product.**

Failure to observe this caution may result in burns.

**Keep away from the safety valve vent.**



**Keep your head away from the safety valve vent when steam escapes. Set the power switch to "OFF" position, shut down the main power and contact the dealer from whom you purchased the product.**

Failure to observe this caution may result in burns.

**Do not stick your fingers in the hinged part of the cover.**

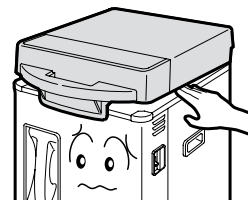

Your fingers may be pinched and injured.



# CAUTION

**Do not wet the product.**

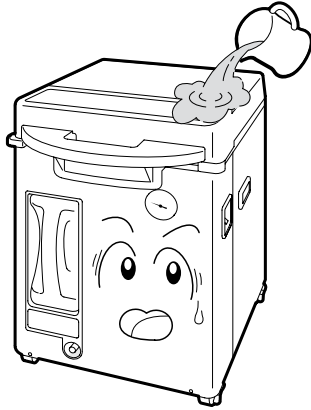

Failure to observe this caution may cause short-circuits in live parts, resulting in electric shock or fire.

**Drain off heating water everyday after use of the product.**

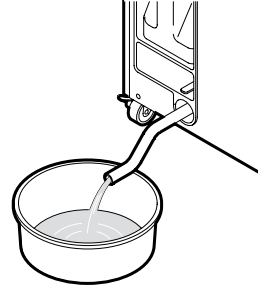

**Insert the attached drain hose in the drain water port and drain water at least 2 hours after operation.** If water is drained out in haste, hot water may splatter, resulting in burns or damage to the floor. Repeated use of the same heating water may corrode the chamber or clog the piping.

**Install the product on a level surface.**

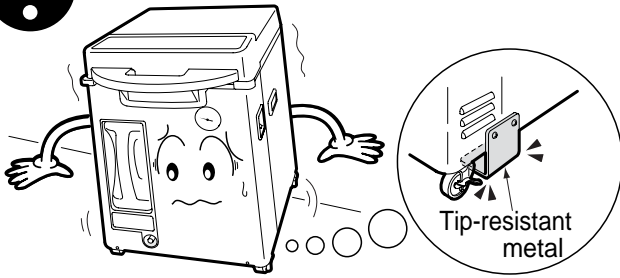

**Anchor the product firmly with the tip-resistant metal attached to the product.** If the product is installed on an inclined surface, hot water in the chamber will spill, resulting in scald or electric shock. Moreover, the product may fall, resulting in injury or damage to the floor.

**Do not move the product with the exhaust tank full of water.**

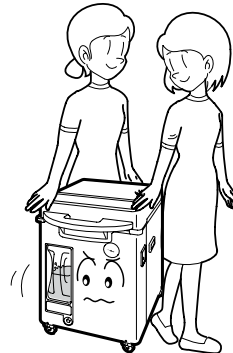

**When moving the product, be sure to discard water in the exhaust tank.** Failure to observe this caution may cause hot water to spill from the exhaust tank, resulting in burns or accident.

**Hold the grips when moving the product.**

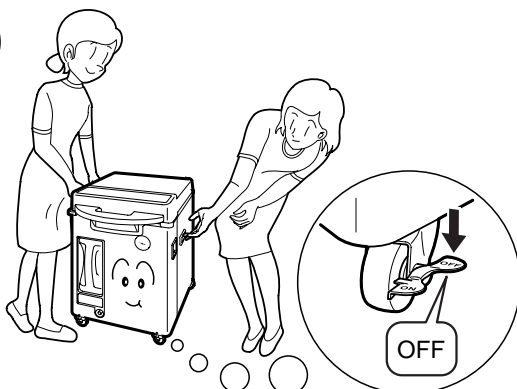

**Unlock the casters when moving the product.** Accidentally dropping the product may result in injury

**If trouble is indicated on the process display, set the power switch in the " OFF " position.**

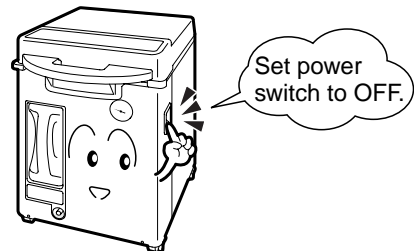

**If the same condition persists even after retrying the operation, set the power switch in the " OFF " position, shut down the main power, and contact the dealer from whom you purchased the product.** Continuing to operate the product anything but proper working order may result in electric shock or fire.

# Precautions in Use

## Use purified or city water as heating water.

Use of well water, saline water, etc. may cause trouble.

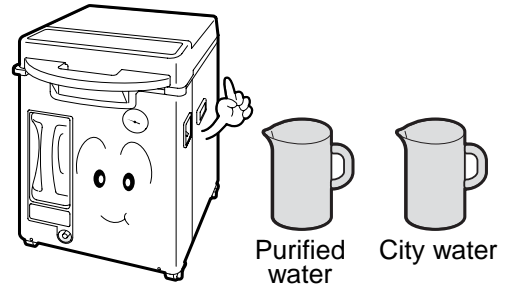

## 翻訳無し

**Do not use the product for anything other than the intended purposes of sterilization, heat-retention and melting.**

Failure to observe this caution may corrode the chamber or clog the piping.

(Do not use the product as a cooking heater.)

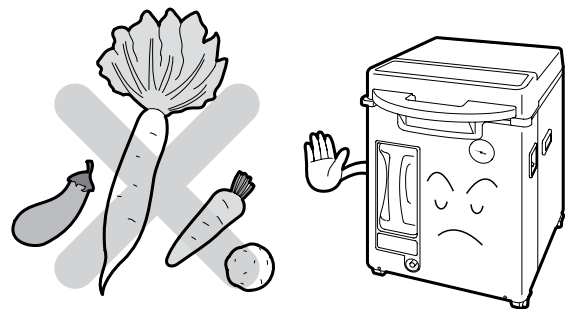

**After sterilizing culture mediums that generated sulfide gas or chlorine gas, clean the chamber on the inside without fail.**

Corrosion of the chamber may cause premature malfunction of the product.

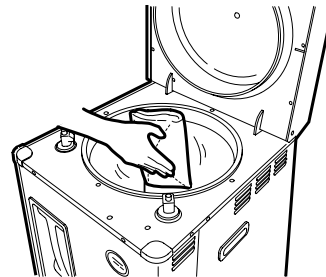

**Set the power switch in the OFF position everyday after use.**

Before leaving the product unused for a long time, be sure to set the power switch in the OFF position and shut down the main power.

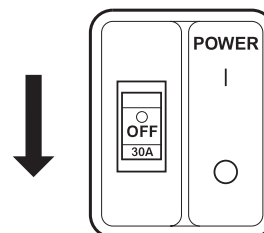

# Before Using the Product

## Installation

- Product environment and conditions of use  
 Location : Indoor  
 Ambient temperature : 5 ~ 40°C    Altitude : 0 ~ 3000m  
 Relative humidity : 50 ~ 80%    Voltage fluctuation : ±10% of nominal voltage
- The boiling point must be set for the product according to the altitude of the location where the product is installed. The boiling point has been set at 100°C at the time of shipment from the factory. Before installing the product in a place 500m higher than sea level, consult your dealer.
- Do not install the product in the following places. Otherwise, trouble may occur with your product.
  - Places exposed to direct sunlight
  - Places where water splashes
  - Inclined surfaces (It becomes difficult to detect heating without water.)
  - Places exposed to air containing salt, sulfur, etc.
  - Humid places
  - Dusty places
- Since steam is emitted from the exhaust tank on the rear side of the product, do not install the product in places where an electric outlet or equipment exists.
- Leave a clearance of more than 15cm behind the product and more than 15cm on the sides of the product. If the product is installed in close proximity to walls, the product may overheat, resulting in trouble.
- Wall surfaces may be marred by venting steam or crack under high humidity.
- **Anchor the product firmly by means of tip-resistant metals (2 pcs. included with the product).**  
 Three tip-resistant metals are included with the product. Use two of them for anchoring the product. If the product is not anchored directly to the floor, anchor it to a floor plate using all three tip-resistant metals.
- Be sure to install the product on a level rigid surface and lock all four casters.
- Be sure to mount the exhaust tank on the rear side of the product and the tank mounting brackets to the rear side of the product. (See page 9.)

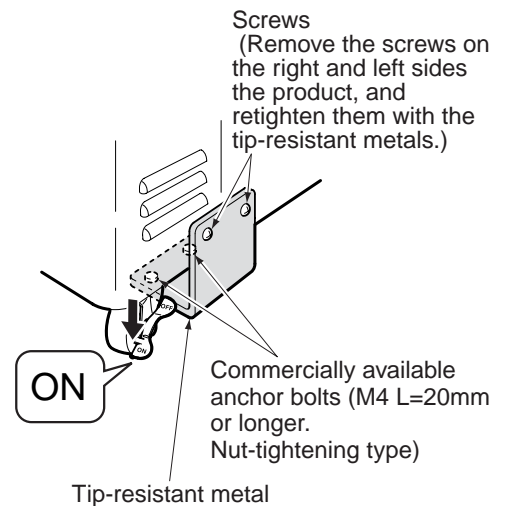
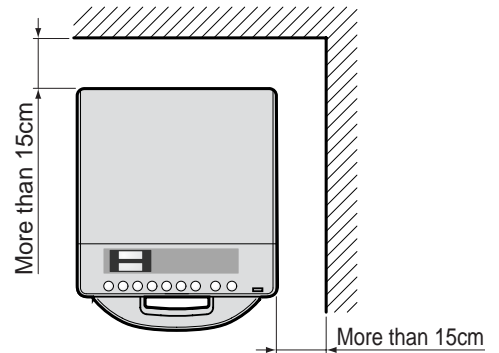

## Power supply and ground connections

- **The unit's power cord must be connected to its own dedicated and properly wired connection outlet where no other plugs are connected.**  
 For 120V units :  
 MLS-3750 ;  
 The unit should be connected to an appropriate receptacle that is rated 16.7 or greater.  
 For 220V units :  
 The 220V versions of the MLS-3751 / 3781 Autoclave are shipped without a plug on the power cord. Use the power-plug when the products is set. The protective grounding conductor of power supply cord must be connected to the contacting member of an attachment plug.  
 rating ;

Power cord	Wire size	MLS-3751	MLS-3781
	Type	AWG14	
Plug	SJT		
		250VAC, 10A or greater	250VAC, 20A or greater

- For 230V units :  
 The 230V versions of the MLS-3751 / 3781 Autoclave are shipped without a plug on the power cord. Use the power-plug which is applied IEC60309 when the products is set. The protective grounding conductor of power supply cord must be connected to the contacting member of an attachment plug.  
 rating ;

Power cord	Wire size	MLS-3751	MLS-3781
	Type	AWG14	
Plug	SJT		
		250VAC, 10A or greater	250VAC, 20A or greater

- **The unit must be connected straight to ground.**  
 The green / yellow conductor of the power cord is the grounding wire. You must ask your dealer or a qualified electrician to do the grounding work involved.

# Names and Functions of Parts

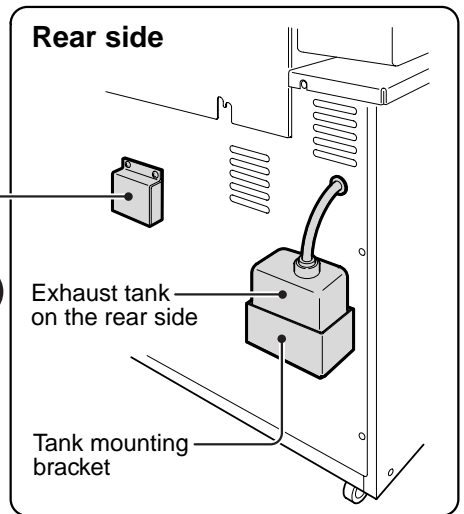

**Safety valve pressure relief port**  
 Steam is discharged through this port if pressure in the chamber rises abnormally.

**Control panel**

**Movable handle**  
 Used for unlocking the cover. The cover can be unlocked by pressing this handle down and pulling toward you.

**Handle**  
 Use for opening/closing the cover.

**Pressure gauge**  
 Indicates the pressure inside the chamber.

**Exhaust tank**  
 Condenses steam emitted from the chamber.

**Tank case**  
 Encases the exhaust tank.

**Exhaust hose**  
 Sends steam and air in the chamber to the exhaust tank.

**Packings**

**Hose in tank**  
 Converts steam discharged from the chamber into water.

**Cover**  
 Cover to shut the chamber tight. It is lined with silicon rubber packing.

**Grip**

**Power switch**

**Cover**  
 Remove this cover to connect the optional printer to the product.

**Caster**

**Exhaust valve**  
 Manually opening/closing valve used for draining heating water from the chamber.

**Drain outlet**  
 Heating water is drained from the chamber through this outlet. Connect the included drain hose to drain heating water.

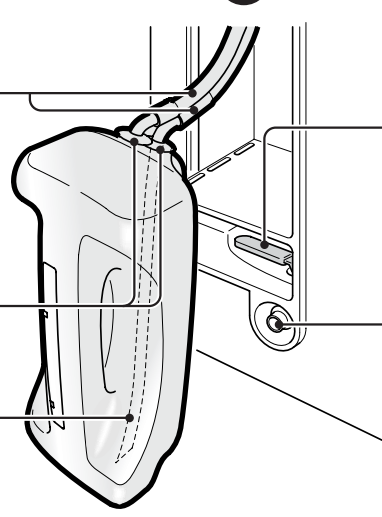
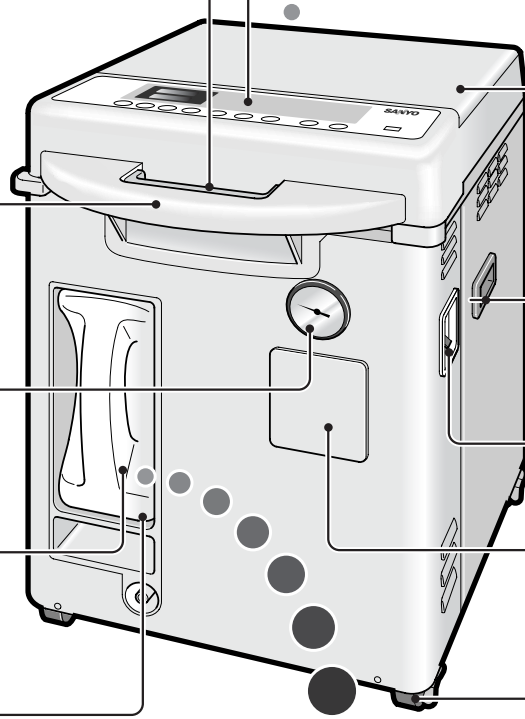

# Control panel

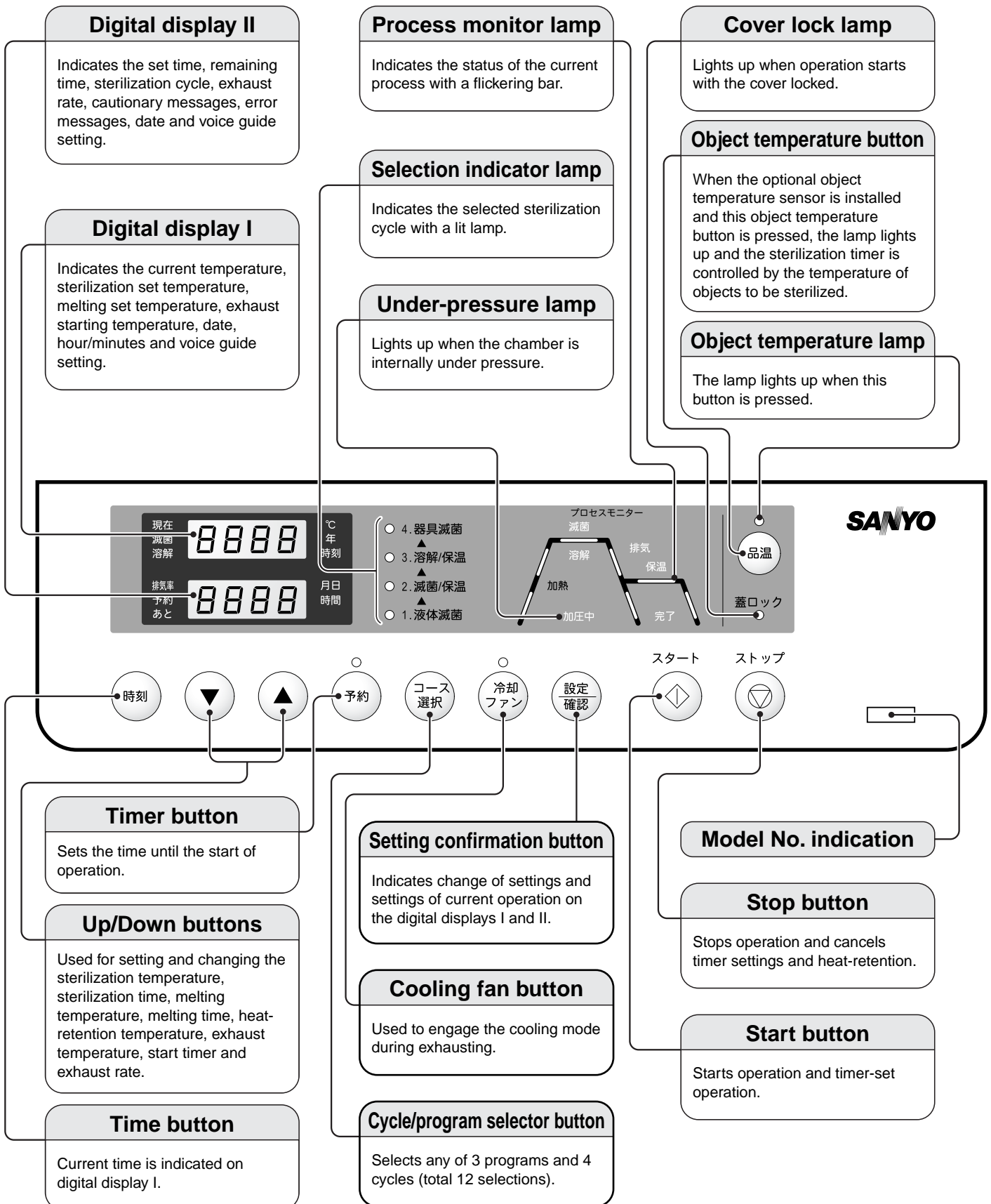

# Explanation of Labels

## Rating label

This label indicates the ratings of the product.

## Warning labels

- **Label 1;**  
This label warns of burns if the operator touches the cover, its periphery or sterilized objects immediately after the end of sterilization.
- **Label 2;**  
This label explains the meanings of “DANGER”, “WARNING” and “CAUTION”. It also explains the precautions for opening and closing the cover.
- **Label 3;**  
This label explains how to install the exhaust tank and precautions of use.
- **Label 4;**  
This label warns against burns that may occur when draining the heating water.
- **Label 5;**  
This label warns against burns that may occur when steam blows from the pressure safety valve.
- **Label 6;**  
This label warns against deterioration of the cover packings caused by sterilization objects.

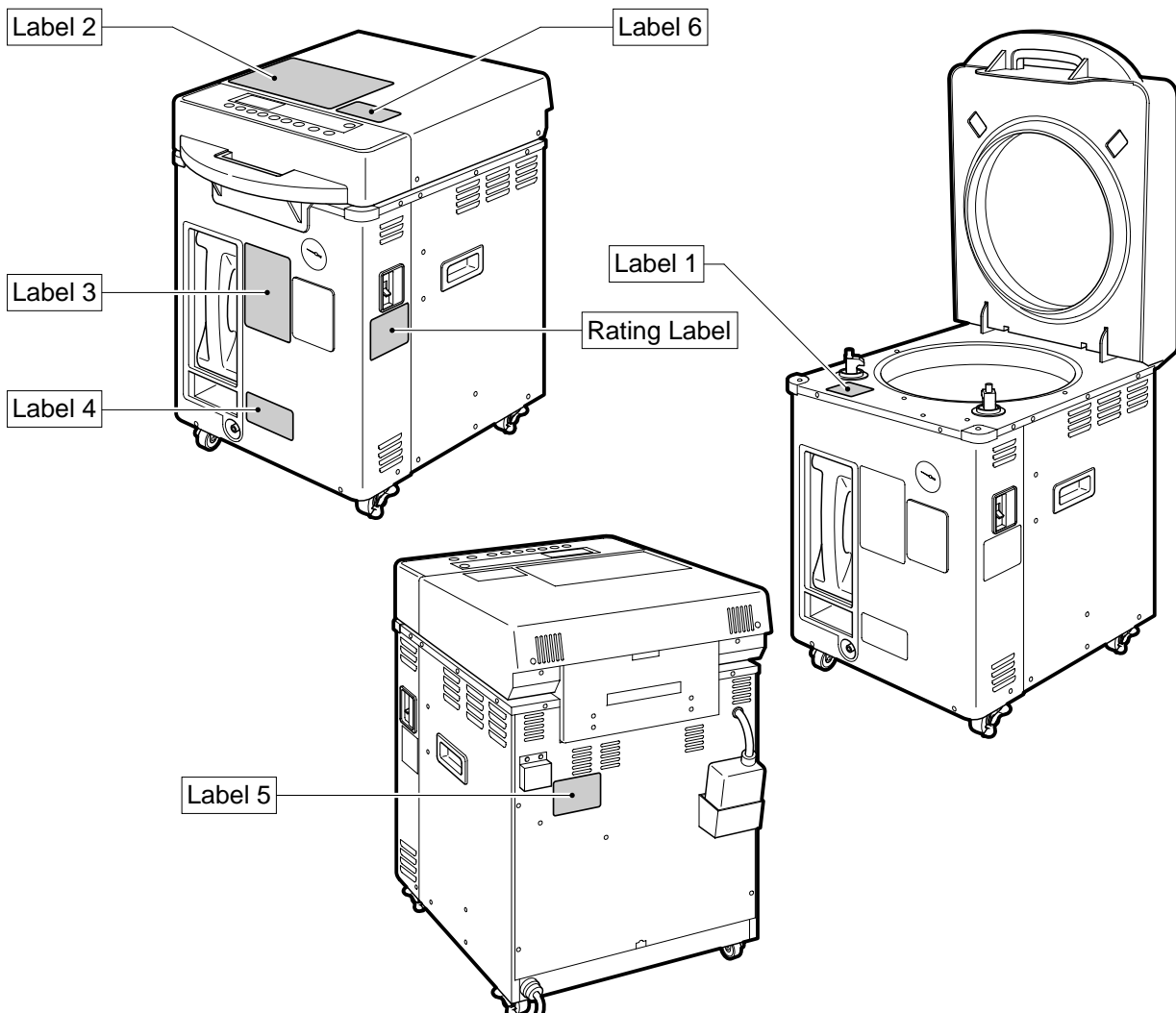

# Sterilization Objects

## ⚠ WARNING

- Do not sterilize objects in a steam-impermeable container or bag.
- Do not seal the object container tightly. Use a porous cap or loosen the cover sufficiently.
- Do not allow the sterilization objects to block the holes or temperature sensor in the chamber.

## Sterilization and melting of liquids such as culture mediums, etc.

### • Capacity of culture mediums and containers

Pour less liquid in the container than the specified volume. Excessive liquid will spill when heated.

### • Sterilization of large volume culture mediums

There is a **time lag** between when the temperature in the chamber reaches the sterilization temperature and when the temperature of the whole culture medium reaches the sterilization temperature. For this reason, this time lag has been included in the sterilization time in advance. Therefore, take the time lag into account when setting the sterilization time.

**Sterilization Setting Time = Sterilization Time + Time Lag**

Liquid Volume	Time Lag	
Agar media in 500ml flask x 1~21, or Agar media in 1000ml flask x 1~12	MLS-3751 8min.	MLS-3781 11min.

### — Recommendation —

An “ **Object temperature sensor** ” that detects the temperature of objects to be sterilized and controls sterilization time is available as an option. Even after this sensor has been installed, control can be switched over to the product's own sensor by pressing the object temperature ON/OFF button. Use this optional sensor to ensure sterilization is more reliable. For details, contact your dealer.

### • Sterilization with the use of plastic containers

Prolong the sterilization setting time even more. Otherwise, poor heat conduction of the container may cause incomplete sterilization.

### • Melting of solidified general agar mediums

Refer to the below table to set the melting time (per flask).

Capacity	Melting Temperature	Melting Time
2 L	100°C	60min.
1 L		45min.

### • Test of Durham tube

Air remaining in the Durham tube can be purged by setting the exhaust temperature and exhaust rate to appropriate levels.

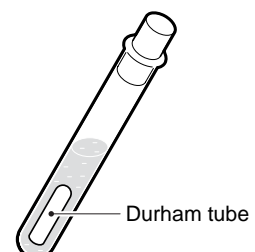
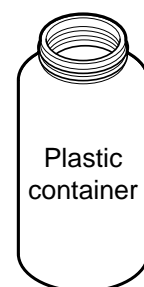
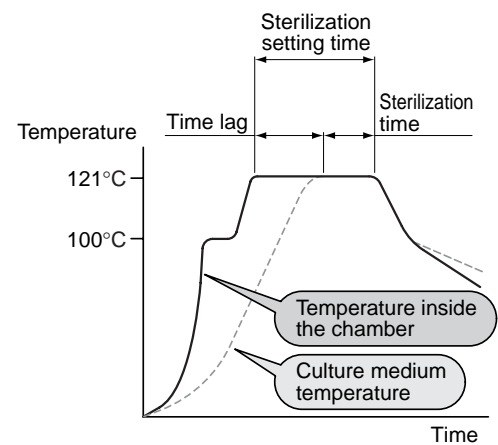
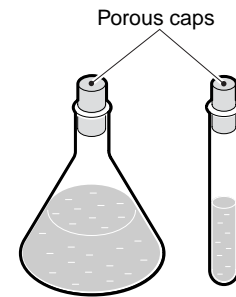

# Sterilization Objects

## Sterilization of equipment, etc.

### WARNING

When sterilizing only containers such as beakers, flasks and test tubes, place them with their openings facing downward or lay them on their sides.

If the containers are placed with their openings facing upward, it is hard for air to sufficiently escape from the container and for steam to sufficiently penetrate inside, thus resulting in incomplete sterilization.

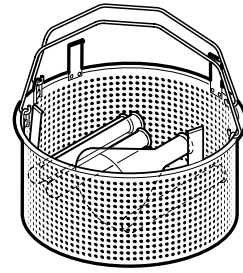

## Sterilization for waste disposal

### WARNING

- When sterilizing waste, pour about 300 ml of water into the sterilization bag and sterilize the waste with the bag open. Sterilizing without water in the bag or with the bag closed may result in incomplete sterilization. An error message may appear due to expansion of the air remaining in the bag.

If the container containing the sterilization objects is broken and the content spills over, sterilize them in the same manner as stated above before discarding.

- When sterilizing the culture medium in petri dish for disposal, uncover the petri dish. If the sterilization is performed with covered petri dish, an error message may appear due to expansion of air remaining in the petri dish.

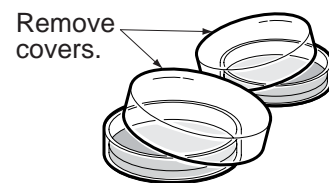
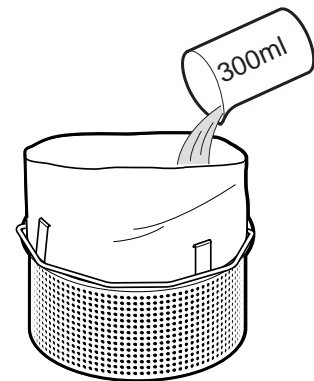

## Sterilization using container with large capacity (10L or more) and narrow mouth

### Advisory Note

When sterilizing liquid in a container with large capacity (10L or more) and narrow mouth, fill the container 50% or more of its capacity.

When a small amount of liquid is sterilized in a container with large capacity and narrow mouth, the pressure builds up during sterilization and steam may burst out from the pressure safety valve. For sterilization of small amount, use a container with large capacity and large mouth or replace it with a small-capacity container suitable for the quantity of liquid.

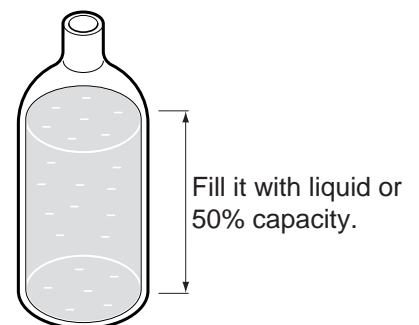

## On sterilization bag

### WARNING

When using the sterilization bag, be sure to put it in the stainless steel basket included with the product and set it in the chamber for sterilization. If the sterilization bag is put directly in the chamber, it may block the temperature sensor or holes in the chamber to raise the pressure and an error message may appear. Be careful not to allow the sterilization bag to be pinched between the opening of chamber and the cover packing. Otherwise, steam may result in trouble.

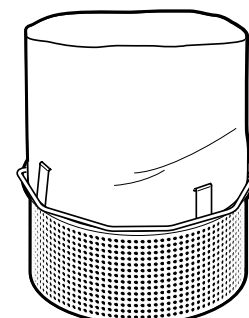

# How to Use

## Basic operating procedure

1. Liquid sterilization cycle	2. Sterilization/Heat-retention cycle	3. Melting/Heat-retention cycle	4. Equipment sterilization cycle	Reference page
	↓			
	1. Install the exhaust tank.			15
	↓			
	2. Set the power switch to ON.			16
	↓			
	3. Open the cover.			16
	↓			
	4. Pour the heating water.			17
	↓			
	5. Place sterilization objects inside.			17
	↓			
	6. Close the cover.			17
	↓			
	7. Press the cycle/program selector button.			18
	8. Change the settings (for program operation).			19 24
	↓			
	9. Press the start button.			20
↓	↓		↓	
Sterilization	Sterilization/Melting		Sterilization	
	↓			
	Heat-retention			
↓	↓		↓	
	10. Operation is completed.			21
	↓			
	11. Open the cover.			21
	↓			
	12. Take out the sterilization objects.			22
	↓			
	13. Set the power switch to OFF.			22
	↓			
	14. Drain off the heating water (for program operation).			22 24

# How to Use

## 1. Install the exhaust tank.

- 1) Take out the exhaust tank from the product and remove the packings.

### Advisory note

Do not pull out the exhaust tank by force from the product with the exhaust hose being connected. Otherwise, trouble may be caused.

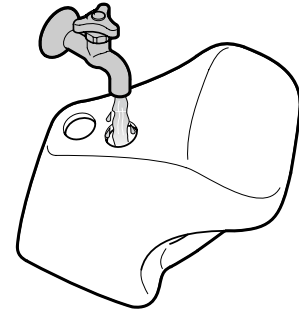

- 2) Pour water up to the LOW (minimum) level mark, insert the packings to the holes of the product and connect the exhaust hoses.



### CAUTION

Steam may leak during operation to cause scald unless the packings are inserted completely and the exhaust hoses are connected completely.

### Memo

The water in the exhaust tank increases in each sterilizing operation. If it will increase up to the HIGH (maximum) level mark, once discard the water and fill the tank with fresh water up to the LOW level mark.

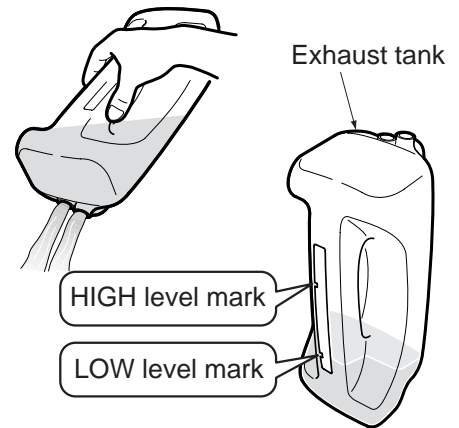

- 3) Make sure that the exhaust hose packings have been inserted completely in the holes of the exhaust tank.



### CAUTION

When the packings are removed from the holes of the exhaust tank, insert them completely back in the holes of the exhaust tank.

### Advisory note

Insert the packings up to the hilt while turning them clockwise and counterclockwise. If they are turned in only one direction, the exhaust hoses will be twisted to cause trouble.

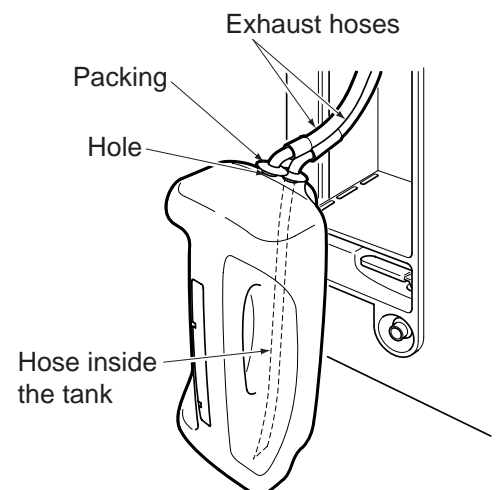

- 4) Stow the exhaust tank inside the product.

Make sure that the exhaust hoses are not bent or twisted. If they are so, air in the chamber is hard to escape and an error message may appear.

## 2. Set the power switch to ON

- The digital display of the control panel lights up. (The boiling point setting temperature appears on the digital display I and “ - - - ” appears on the digital display II for the first 2 seconds.)



The figure shown above is for the case when the boiling point set temperature is 100°C.

### Digital display

#### ■ Cover being CLOSE

Settings (set temperature and sterilization time/cycle) are indicated.

Digital display I: Sterilization temperature

Digital display II: Sterilization time and cycle indicated alternately

This status is referred to as “ Standby Status”.



To check the temperature inside the chamber, Press the

▼ and ▲ buttons simultaneously.

The current temperature is indicated while these buttons are kept pressed.



Digital display I: Temperature inside the chamber

Digital display II: Temperature of heating water

If the temperature is lower than 25°C, “Lo” appears.

#### ■ Cover being OPEN

The current temperature of the heating water in the chamber is indicated.



The figure shown above is for the case when the temperature of the heating water in the chamber is 30°C.

## 3. Open the cover. (The cover can not be opened unless the power switch is turned ON)

### 1) Be sure to check the following points before opening the cover.

If you attempt to open the cover by force, trouble may be caused with the product.

- Power switch is turned ON.
- Pressure gauge indicates 0MPa.
- COVER LOCK lamp goes out.

- While pressing down the handle,
- Pull the movable handle toward you.

The cover can not be unlocked unless the handle is pressed down.

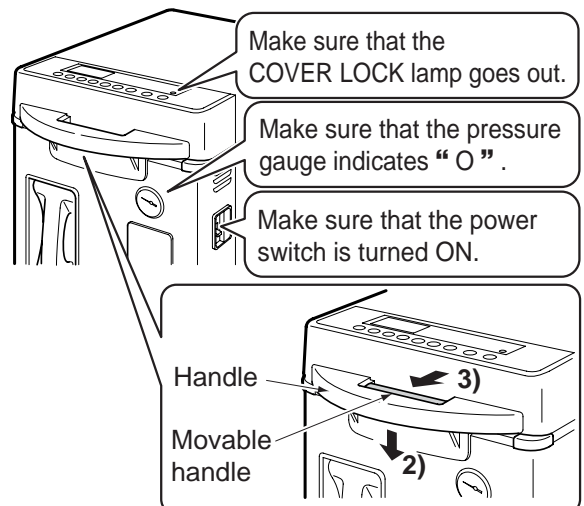

### 4) Open the cover.

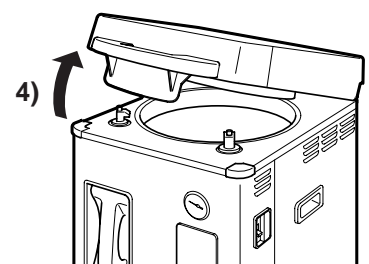

# How to Use

## 4. Pour the heating water.

- Make sure that the drain valve is closed.
- Set the heater cover in the chamber.
- Pour the water until the tip of the water level bracket of the heater cover is immersed in the water. Since the amount of water decreases with every sterilizing operation, check the water level ahead of operation.

### MEMO

The amount of heating water is 3.5 liters.

### Advisory note

Purified water is best suited as heating water. If it is unavailable, use city water instead.

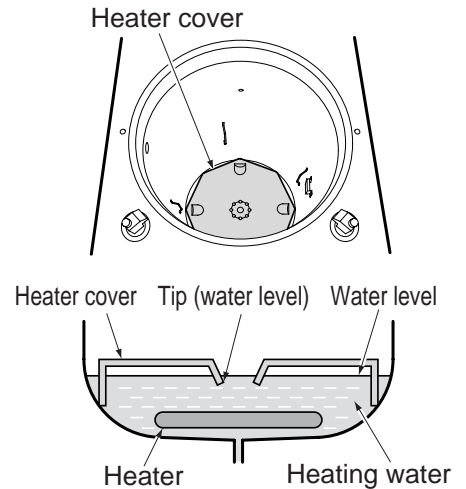
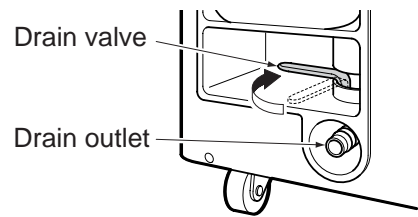

## 5. Place the sterilization objects inside.

- When using the attached stainless steel baskets in pile, be sure to place the small basket on the top.
- Set the baskets gently along the guides in the chamber.
- Bring down the grip.

### ⚠ WARNING

Do not allow the sterilization objects to block the holes or temperature sensor in the chamber and do not apply undue force to the temperature sensor.

### MEMO

Before, starting operation, check again how to place the sterilization objects in reference to the "On Sterilization Objects" (page 12 ~ 13).

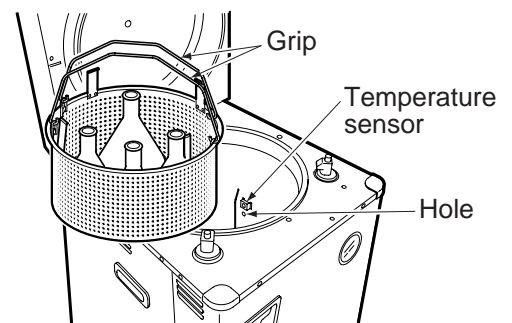
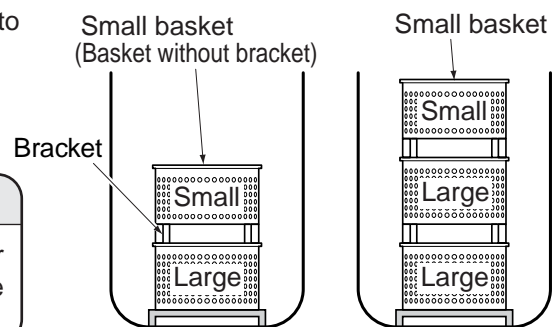

## 6. Close the cover.

- 1) Make sure on the digital display I that the temperature inside the chamber is under 60°C  
(“L □” appears when the temperature is under 25°C)



### MEMO



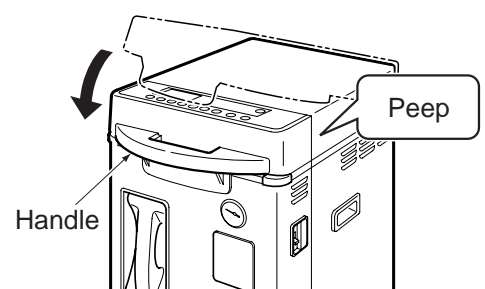

If the cover is closed when the temperature inside the chamber is over 60°C due to continuous operation, etc., the air inside the chamber will expand suddenly to make it difficult to open and close the cover. In this case, wait until the temperature will lower below 60°C.

- 2) Check → to see whether or not the cover packings and the chamber opening are free from dirt or dust  
If they are dirty or dusty, steam may leak to cause trouble. Keep them always clean.  
(Cover packings and chamber opening → See page 26.)
- 3) Close the cover while bringing down the handle.  
Then, a peep sound is heard, and the sterilization set temperature appears on the digital display I and the sterilization time or the sterilization time and cycle appear alternately on the digital display II.



## 7. Press the cycle/program selector button

- 4 cycles of sterilization can be selected according to the purpose of use.  
3 settings can be memorized for each cycle according to the condition of use. The settings can be changed by  or  button.
- Programmed settings can be changed. Change them if necessary. (\*Refer to the changeable range.)  
**Change the settings**  See page 19.
- The product has been set at the values as shown in the table below at the time of shipment.

Cycle/Program	Steriliz. Temp.	Steriliz. Time	Heat-retent. Temp.	Exhaust Temp.*	Exhaust Rate *	Application/Function
 1. Liquid Steriliz.	1 - 1	121°C	27min	—	Boiling Point + 0°C	For sterilization of liquids such as water, culture medium and test liquid. After the completion of sterilization process, the sterilization objects are gradually cooled naturally, and when the temperature reaches the exhaust set temperature, the exhaust valve opens.
	1 - 2	121°C	27min	—	Boiling Point + 0°C	
	1 - 3	121°C	27min	—	Boiling Point + 0°C	
	* Changeable range	115°C ∩ 135°C	1min. ∩ 5hrs.	—	Boiling Point + 0°C ∩ 45°C	1~5
 2. Steriliz./ Heat-retent.	2 - 1	121°C	27min	50°C	Boiling Point + 0°C	For sterilization of liquids such as water, culture medium and test liquid. Like in the liquid sterilization cycle, this cycle starts with sterilization process followed by exhaust and the temperature is kept at the preset heat-retaining temperature.
	2 - 2	121°C	27min	50°C	Boiling Point + 0°C	
	2 - 3	121°C	27min	50°C	Boiling Point + 0°C	
	* Changeable range	115°C ∩ 135°C	1min. ∩ 5hrs.	45°C ∩ 60°C	Boiling Point + 0°C ∩ 45°C	1~5
 3. Melting/ Heat-Retent.	3 - 1	Melting temp. 100°C	Melting time 30min	50°C	—	For melting and heat-retention of culture medium. • Simply to keep the culture warm, set the melting time to “0”. Melting temperature setting is not needed. • When the operation is stopped or the cycle is completed, the cycle/program will be set automatically to 1-1 program.
	3 - 2	Melting temp. 100°C	Melting time 30min	50°C	—	
	3 - 3	Melting temp. 100°C	Melting time 30min	50°C	—	
	* Changeable range	Melting temp. 60°C ∩ 114°C	Melting time 0min. ∩ 5hrs.	45°C ∩ 60°C	—	1~5
 4. Equipment Steriliz.	4 - 1	135°C	3min.	—	—	For sterilization of equipment such as flasks, beakers, etc. which can withstand a sudden pressure drop at the exhaust stage. After the completion of sterilization process, the exhaust valve opens at the temperature below 135°C, and the sterilized objects are cooled down. • Liquids may boil over when they are sterilized.
	4 - 2	135°C	3min.	—	—	
	4 - 3	135°C	3min.	—	—	
	* Changeable range	115°C ∩ 135°C	1min. ∩ 5hrs.	—	—	1~5

\* Heat-retention time is fixed at 72 hours. To cancel it on way, press the  button.

\* The exhaust temperature means the temperature for opening the exhaust valve after the completion of sterilization process and discharging steam from the chamber.  
Change the setting when using a Durham tube, etc.

(The temperature shown on the digital display is the temperature to be added to the boiling point.)

\* The exhaust rate means that the exhaust valve is opened/closed in regular intervals in the exhaust process and the steam in the chamber is discharged. The exhaust time can be shortened as compared to natural cooling according to the exhaust rate selected. Too much exhaust rate may cause boiling out depending on the kind and quantity of the objects to be sterilized. Use due care for selection of exhaust rate.

### Rough Standard of Exhaust Rate

Figure Indicated	1	2	3	4	5
Exhaust Rate %	Full close	←—————→			Full open

# How to Use

## 8. Change the settings

- It is possible to change the settings (sterilization temperature, sterilization time, melting temperature, melting time, heat-retention temperature, exhaust temperature and exhaust rate) according to need. The settings that have been changed are saved in memory even when the power switch is turned OFF. (Once the operation is started, the settings of the sterilization temperature and melting temperature can not be changed. The sterilization time, etc. can be changed but not saved in memory.) (Changeable range: See page 17.)



- Press the button. Beep  
Setting menu flicker.  
The setting menu moves each time this button is pressed.

- Press the or button to change the setting.

### MEMO

The setting value is incremented or decremented each time the or button is pressed. If the button is kept pressed, the value is rapidly incremented or decremented and it stops finally at the maximum or minimum value.

- Press the button to flicker the next menu. Beep  
Press the or button to change the setting.

Press the button.

↑↓ Repeat this procedure.

Press the or button to change the setting.

For setting menu to be left unchanged, simply press the button.

- Finally, press the button.  
When the setting menu is entered, a buzzer sound is heard and the changed setting is saved in the program.

\* The flickering status is left standing for 1min., the changed setting is not updated and the product turns to be standby status. (Standby status : See page 15.)

Each time the button is pressed, the setting menus flicker one by one in the sequence as follows:

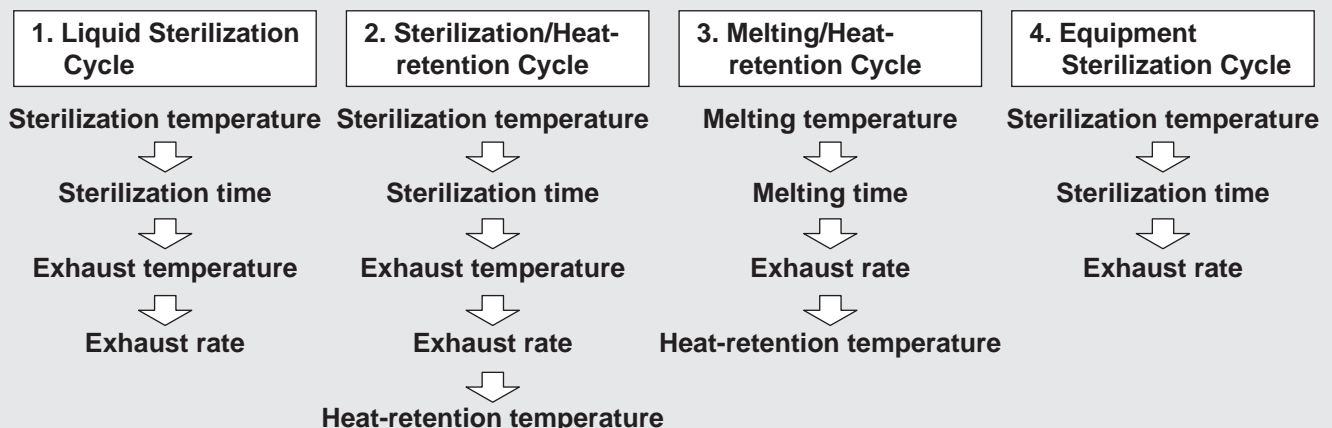

## 9. Press the button.

### ■ In the case when the operation is started after selection of liquid sterilization cycle, sterilization/heat-retention cycle or equipment sterilization cycle

- When the sterilization setting time is longer than the heat-retention time shown in the table below,

1) Press the  button. 

\*The process starts.

The cooling fan is operated automatically after the completion of sterilization.

If the cooling fan operation not needed, press the cooling fan button to turn OFF.



- On sterilization setting time

The sterilization time is based on Japanese Pharmacopeia and the standards of JIS T 7324-2005 Small-sized High-pressure Steam Sterilizer for Medical Use and it does not guarantee the sterilization. Be sure to confirm the sterilization by sterilization indicator.

- When the sterilization setting time is shorter than the heat-retention time shown in the table below,

1) Press the  button. 

The sterilization setting temperature appears on the digital display I and the sterilization setting time and cycle appear alternately on the digital display II.



Confirm the setting.

2) Press the  button. 

The process starts.

Sterilization Setting Temperature (°C)	Liquid Sterilization Heat-retention Time	Equipment Sterilization Heat-retention Time
115	37Min.	30Min.
121	27Min.	20Min.
126	22Min.	15Min.
132	12Min.	5Min.
135	10Min.	3Min.

### ■ In the case when the operation is started after selection of melting/heat-retention cycle

1) Press the  button. 

The melting setting temperature appears on the digital display I and the sterilization setting time and cycle appear alternately on the digital display II.

2) Press the  button. 

The process starts.

- When the cover is opened after the completion of process, the cycle/program is set automatically at the 1-1 program of the liquid sterilization cycle.

\*When the temperature inside the chamber reaches the melting setting temperature, the temperature inside the chamber appears on the digital display I and the sterilization remaining time or melting remaining time appears on the digital display II.



#### Temperature inside chamber



#### Sterilization remaining time or melting remaining time (after the temperature reaches the sterilization temperature or melting temperature)



Cover is not closed.

#### Advisory note

If the cover is not closed completely, “L id” (cautionary message) appears on the digital display II. In this case, bring down the handle again and press the  button when the buzzer sounds.

- The COVER LOCK lamp lights up after starting. When the lamp is lit, the movable handle is locked to make it impossible to open the cover.

# How to Use

## To stop operation

See page 22

## To check the settings during operation

Press the  button.

The settings are indicated when this button is pressed.

## To change the settings during operation

The settings of sterilization time, melting time, heat-retention temperature, exhaust temperature, exhaust rate, exhaust fan operation start/stop can be changed. However, the changes will not be saved in memory. When changing the settings, see page 18.

\*The sterilization temperature can not be changed during operation.

## 10. Operation is completed.

### • Liquid sterilization cycle or equipment sterilization cycle

The buzzer sounds and the completion of cycle is indicated on the digital display II.

- In the liquid sterilization cycle, the completion of cycle is indicated at 64°C
- In the equipment sterilization cycle, the completion of cycle is indicated at 74°C

### • Sterilization/Heat-retention cycle or melting/heat-retention cycle

When the heat-retention cycle starts, the buzzer sounds and the bar sign of "Heat-retention" of the process indicator lamps flickers. The heat-retention elapsed time is indicated on the digital display II.

After the heat-retention has been continued for 72 hours, the operation is completed, the buzzer sounds and the completion of cycle is indicated on the digital display II.

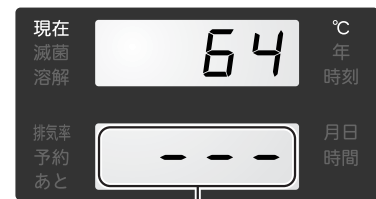

Indication of completion

## 11. Open the cover.

### 1) Be sure to check the following points before opening the cover.

Forcible opening of the door may cause trouble.

- Pressure is lowered to 0MPa.
- COVER LOCK lamp is lit.

When the COVER LOCK lamp is lit, the temperature or pressure inside the chamber rises to make it impossible to pull the movable handle toward you.

### 2) While bringing down the handle,

### 3) Pull the movable handle toward you to unlock the cover.

### 4) Pull up the handle to slightly open the cover and wait until no steam comes out.

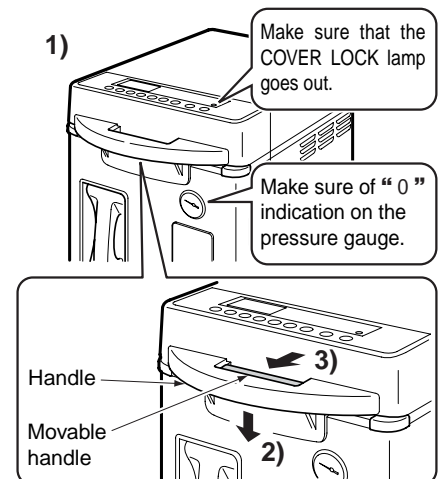

## CAUTION

Since high-temperature steam will escape when the cover is opened, wait until the steam dissipates. During this time, keep your head away from the product.

### 5) Open the cover slowly.

Sudden opening of the door may break the container of sterilization objects and cause the culture medium to spill over.

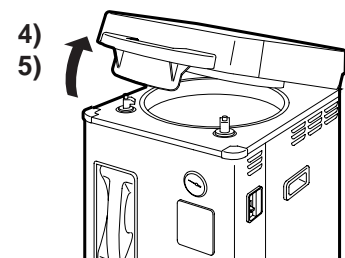



## 12. Take out the sterilization objects.

- Take out the sterilization objects when steam has been purged completely from the chamber.

### CAUTION

When taking out the sterilization objects, wear heat-resistant leather gloves for prevention of burn.

### When taking out the sterilization objects (objects to be melted) during heat-retention.

- To suspend the heat-retention, press the  button. The heat-retention is suspended. In the case of the melting/heat-retention cycle, the cycle/program is set at this time automatically to the 1-1 program of the liquid sterilization cycle. If the  button is not pressed, the heat-retention continues for 72 hours.
- For simple heat-retention, change the melting time to “0” in the “melting/heat-retention cycle” and press the  button.

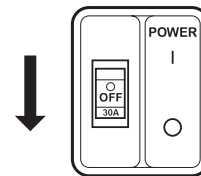
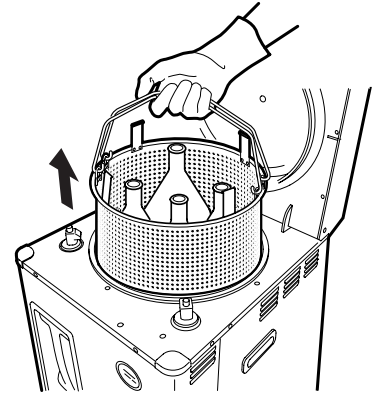

## 13. Set the power switch to OFF.

- Set the power switch to OFF at the end of daily use.

## 14. Drain off the heating water.

- 1) Open the cover.
- 2) Open the drain valve.
- 3) After draining water, close the drain valve without fail.

### CAUTION

Drain off the heating water with the cover being opened 2 hours later or longer after the completion of operation.

### Advisory note

Repeated use of the same heating water may corrode the chamber and clog the piping.

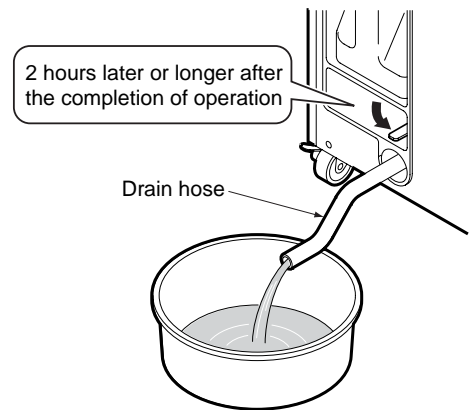



## For continuous use

- When using the product consecutively, make sure on the digital display I that the temperature inside the chamber is below 60°C.

### Memo

If the cover is closed when the temperature inside the chamber is raised due to continuous operation, etc., the air inside the chamber will rapidly expand, making it difficult to open/close the cover. Wait until the temperature lowers below 60°C.

- To check the current temperature inside the chamber in standby status, press the  and  buttons simultaneously. (See page 15.)



When the temperature inside the chamber is 59

# How to Use

## To stop the operation



- 1) Press the  button. Beep
- The product is in standby status.

2) Check the following points before opening the cover.

- Pressure is lowered to 0MPa.
- COVER LOCK lamp goes out.  
When the COVER LOCK lamp is lit, the temperature or pressure inside the chamber rises to make it impossible to pull the movable handle toward you. sterilization objects, wear heat-resistant leather gloves for prevention of scald.

### To open the cover immediately

- Lower the pressure and temperature inside the chamber forcibly in the procedure as follows:  
( If liquid boils over in liquid sterilization, clean the inside of the chamber. )  
Inside of the chamber : See page 25.

- 1) Press the  button while pressing the  button.
- 2) To stop the exhaust, press the  button again.
- 3) Check the following points before opening the cover.
  - Pressure is lowered to 0MPa.
  - COVER LOCK lamp goes out.

When the COVER LOCK lamp is lit, the temperature or pressure inside the chamber rises to make it impossible to pull the movable handle toward you.



## ⚠ CAUTION

The temperature inside the chamber is raised hot. When taking out the sterilization objects, wear heat-resistant leather gloves for prevention of scald.



## For timer operation



The operation can be programmed up to at 23:59 of 7 days later from the current date and time.

1) Press the  button.

The lamp above the timer button lights up and the timer lamp on the digital display II lights up, and the current date and time flicker.



2) Press the  and  buttons to set the operation starting day and press the  button.

- The figures change quickly when the  or  button is kept pressed.
- The time on the digital display I flickers.



3) Similarly, set the hour and minute in turn.

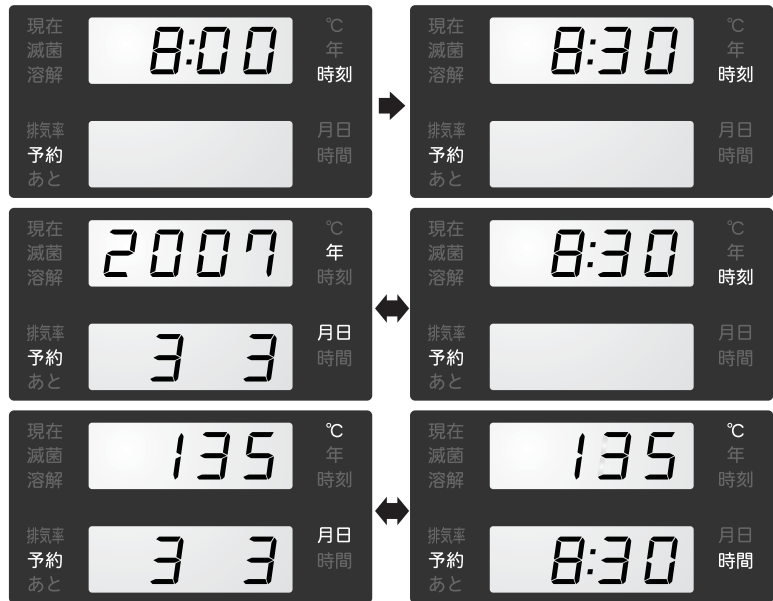

4) Press the  button. (Timer operation starts.)





The sterilization temperature appears on the digital display I and the date and time appear alternately on the digital display II.

\*To cancel the timer operation, press the  button.

### Timer setting

Year, month, day, hour and minute have been set at the time of shipment.

If the timer setting is needed anew after replacement of parts, etc., set it in the procedure as follows:

When the pushbuttons  and then  are pressed, the Christian year entry appears and flickers. Enter Christian year by  and  buttons and press the  button.

Enter the month, day, hour and minute in the same manner.

When setting the minute, press the  button to set exact time by time signal.

## On Power Failure

- In power failure, all of the control panel displays are cleared.
- When power failure occurs or when the power switch has been set to OFF, the safety device works to lock the cover, making it impossible to open the cover.

### To use the product after restoration of power

- When the power is restored, the control panel displays are in standby status.

#### 1) Check the following points before opening the cover.

- Pressure is lowered to 0MPa.
- COVER LOCK lamp goes out.

When the COVER LOCK lamp is lit, the temperature or pressure inside the chamber rises to make it impossible to pull the movable handle toward you.

#### 2) Take out the sterilization objects

If liquid boils over in liquid sterilization, clean the inside of the chamber.

Inside of the chamber : See page 25.



### CAUTION

When taking out the sterilization objects, wear heat-resistant leather gloves for prevention of scald.

#### 3) Check the sterilization by sterilization indicator.

Objects can not be sterilized in some cases.

#### 4) If objects can not be sterilized, repeat the operation.

# On Voice Guide

- The voice guide of the product is nothing but an auxiliary function. For safe use this function, please read the precautions and instructions for use in this manual.
- The voice guide of this product can be set to either “ Standard Mode ” or “ Warning Mode ”.  
The voice guide has been set at “ Standard Mode ” at the time of shipment.

## Standard Mode

- For safe use of the product, precautions and operating instructions are informed in voice.

[Example of Liquid Sterilization]

When the cover is closed	Was the amount of heating water checked?
Press the cycle selector button.	The liquid sterilization cycle is now in operation.
Press the set./confirm. button.	Set the sterilization temperature.
Press the start button.	The liquid sterilization operation will start.
Operation is completed.	The liquid sterilization operation has been completed.

## Warning Mode



- Points to be confirmed and checked when the safety device worked to stop the operation of the product will be guided in voice.

[Example of Liquid Sterilization]

The product starts with the cover being open.	The cover is not closed.
When opening the cover	Open the cover, paying attention to steam.
In E5 (Heating without water)only	The safety device worked. Check the amount of heating water.
In CH checking	Now is the time for checking.

\*In the Standard Mode, the messages of the Warning Mode are informed also by voice guide.

## To change the voice guide settings

- 1) Press the  button for longer than 2 sec. while pressing the  button in standby status.

 appears on the digital display I.

 appears on the digital display II.

The  is the message that is used only for setting the optional printer.

- 2) Press the  button.

 appears on the digital display I.

 appears on the digital display II.

- 3) Press the  and  buttons to change the figure on the digital display II.

Display II	Mode	Sound Volume
3	Standard Mode	High
2		Middle
1	Warning Mode	High

- 4) Press the  button for setting.

Voice guide starts in set mode.



# Maintenance



## CAUTION

- Proceed with maintenance work after the product has been sufficiently cooled down.
- Be sure to set the power switch to OFF before starting maintenance work.

Do not use thinner, benzene, etc. that may give damage to the product.

## Product

Soak soft cloth with water or neutral detergent, squeeze the cloth well and wipe off dirt.

(Standard frequency of cleaning: Once a month)

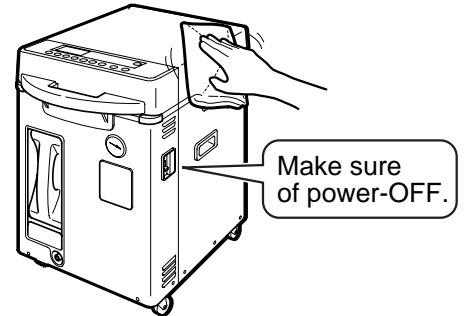

## Exhaust tank/Exhaust tank at rear side

If the inside of the exhaust tank becomes dirty, pour hot water mixed with neutral detergent into the tank and shake it well to remove dirt, and rinse it thoroughly with water.

(Standard frequency of cleaning: Once a month)

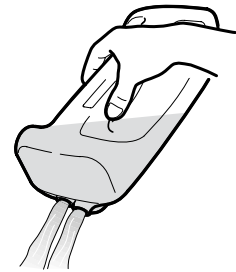

## Cover packings and chamber opening

Wipe them carefully with soft cloth impregnated water. Contaminated cover packings and chamber opening may cause steam leakage.

(Standard frequency of cleaning: Once a month)

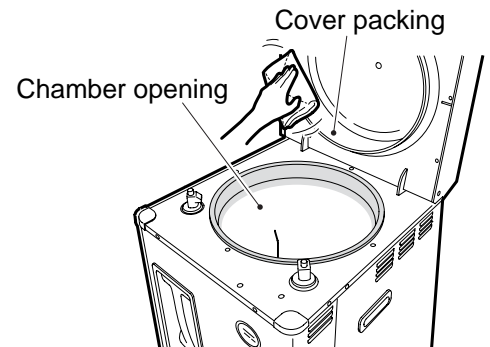

## Chamber inside

- Chamber inside
  - Wipe the chamber inside with soft cloth impregnated water or neutral detergent. If it is difficult to get the dirt out of the chamber, wipe it well with nylon scrubber impregnated with neutral detergent and then rinse it with running water.
  - In the case of liquid sterilization, wash away the dirty liquid with water when it is boiling over.

(Standard frequency of cleaning: Once a month)

- Bottom of chamber inside
  - Remove the heater cover and wash the bottom carefully by means of a hand brush paying attention so as not to give damage to the sensor.

(Standard frequency of cleaning: Once a month)

- As for the cleaning of heavy soil, please consult your dealer.

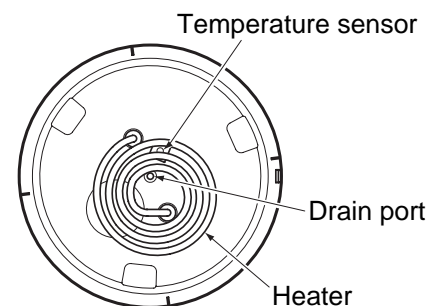
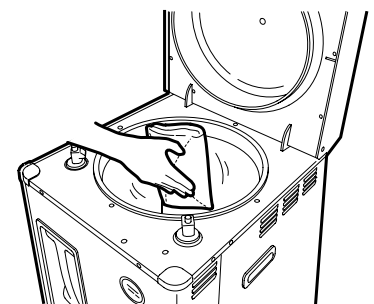

(Plan of bottom of chamber inside)

# Troubleshooting

If any trouble arises during use, check out the following points and take the suggested remedy.

## Before asking for servicing

Trouble	Checking Point	Remedy	See page
<b>Power is not supplied.</b>	<ul style="list-style-type: none"> <li>Is the power supply of the dedicated connection outlet turned ON?</li> <li>Is there a power failure?</li> </ul>	• Turn ON the power supply.	–
		• Wait until the power is restored.	–
<b>Cover will not close.</b>	• Is the temperature inside the chamber below 60°C	• Wait until the temperature lowers below 60°C	17
<b>Operation will not start.</b>	• Is the power switch turned ON?	• Turn ON the power switch.	16
	• Was the buzzer sound heard when the handle retaining cover closed?	• Press down the handle by force to close the cover until the buzzer sounds.	17
	• Is the timer lamp on the digital display lit?	• Press the stop button to cancel the timer operation.	24
<b>Temperature will not be raised in heating process. (It does not reach the sterilization temperature.)</b>	• Is the exhaust hose bent?	• Straighten the exhaust hose.	15
	• Is the selection of cycle wrong? (Has the melting cycle been selected?)	• Select the right cycle.	18
	• Is the boiling point set suitably for altitude? Check the boiling point temperature.	• If the boiling point is not set suitably for altitude, please contact your dealer.	8 · 16
<b>Steam leaks from the safety valve vent. (Pressure for sterilization is abnormally high.)</b>	• Is the temperature sensor inside the chamber blocked by sterilization objects?	• Stop the operation and set the sterilization objects apart from the temperature sensor.	17
	• Is a small amount of liquid sterilized in a container with large capacity (10L or more) and narrow mouth?	• Fill the container with 50% of the liquid or transfer the liquid into a container with large mouth.	13
	• Are beakers, etc. sterilized with their openings facing upward? (Sterilization of container only)	• Direct the openings downward or lay them down.	13
<b>Cover will not open.</b>	• Is the power switch turned ON?	• Turn ON the power switch.	16
	• Is there a power failure?	• Wait until the power is restored.	24
	• Is the inside of the chamber still high in temperature and pressure? (COVER LOCK lamp is lit.)	• Wait until the COVER LOCK lamp goes out>	16 · 21

## The following symptoms are not troubles.

Symptom	Explanation
<b>A buzzing noise is heard from the product.</b>	• Operating sound of solenoid valves that discharges air and steam from the chamber inside.
<b>The upper left side of the product is heated.</b>	• Operating heat of solenoid valves that discharges air and steam from the chamber inside.
<b>Crumping sound is heard from the exhaust tank.</b>	• This sound is heard when air and steam are discharged from the chamber inside.
<b>Steam is discharged from the exhaust tank at the rear side.</b>	• This steam is generated when steam is discharged in heating process and exhaust process.

## If any cautionary message or error sign appears and flickers on the digital display.

- If any cautionary message appears and flickers during use, check out the following points and take the suggested remedy.

Cautionary Message	Meaning	Remedy	See page
<i>L id</i>	Cover is not closed completely.	Press down the handle by Force to close the cover until the buzzer sounds.	20
<i>Hot</i>	When the start button is pressed, the temperature inside the chamber is 5°C higher than the preset temperature.	When the temperature inside the chamber has lowered, press the start button,	-
<i>H05E</i>	The exhaust hose is bent.	Take out the exhaust tank and straighten the exhaust hose. After the exhaust hose has been straightened, cautionary message may appear several times. If the product can not be restored, press the stop button and do it over again. If the product will not return to the normal status, Contact the dealer from whom you purchased the product.	15
<i>door</i>	Door opening/closing can not be confirmed	Open the door once and then close and start the operation	-

- If an error arises during use, the error sign appears and flickers and at the same time buzzer sounds intermittently, and the safety device works to stop the operation automatically. Check the following points and take appropriate measure.

How to rest the error sign: Keep pressing the  button or set the power switch to OFF.

Error Sign	Meaning	Remedy	See page
<i>E 1</i>	Trouble with the temperature sensor	Contact the dealer from whom you purchased the product.	-
<i>E 2</i>			
<i>E 3</i>	The over-temperature prevention device in the chamber is working.		
<i>E 4</i>	The temperature of the object temperature sensor (optional) rises abnormally high.		
<i>E 5</i>	• Heating water is scarce or depleted.	• Supply heating water in the chamber.	17
<i>E 6</i>	The movable handle lock can not be unlocked	Contact the dealer from whom you purchased the product.	-
<i>E 7</i>	The movable handle lock is not working. The cover lock is not working.	• Contact the dealer from whom you purchased the product. • The cover can not be opened despite that the pressure gauge shows “ 0 ” and the COVER LOCK lamp is not lit. Open the cover after the temperature inside the chamber lowers cool enough to be able to open the door.	21
<i>E 8</i>	The pressure rises abnormally high. • The exhaust hose is bent.	• Take out the exhaust tank and straighten the exhaust hose. After the exhaust hose has been straightened, cautionary message may appear several times. If the product can not be restored, press the stop button and do it over again. If the product will not return to the normal status, contact the dealer From whom you purchased the product.	15
	• The mouth of the sterilization bag is closed.	• Open the mouth of the sterilization bag.	13
	• No water in the sterilization bag • Boiling point is not set suitably to the altitude.	• Fill the sterilization bag with 300 ml of water. • Ask your dealer to set the boiling point suitably to the altitude.	13 8
<i>E 9</i>	Boiling point is set at low level and the pressure is not raised normally.	Contact the dealer from whom you purchased the product.	-
<i>E 10</i>	Trouble with control device		



\*If the product will not operate normally even after taking the above-mentioned remedy, stop the operation immediately and contact your dealer.

# Specifications

Product Designation		Labo Autoclave (High-pressure Steam Sterilizer)	
Model Designation		MLS-3750(N)	MLS-3780(N)
Power supply		120V unit: 120VAC ( 50/60Hz ), 16.7A 220V unit: 220VAC ( 50/60Hz ), 9.1A 230V unit: 230VAC ( 50/60Hz ), 8.7A	220V unit: 220VAC ( 50/60Hz ), 18.2A 230V unit: 230VAC ( 50/60Hz ), 17.4A
Power Consumption		2kW	4kW
External Dimensions		600(W) x 560(D) x 754(H) mm	600(W) x 560(D) x 979(H) mm
Weight		63kg	220V product: 74kg, 230V product: 82kg
Internal Capacity		59L	83L
Effective Internal Capacity		50L	75L
Chamber Dimensions		370 (dia.) x 415(D) (Effective depth including cover: 463) mm	370 (dia.) x 630(D) (Effective depth including cover: 688) mm
Chamber Material		SUS304 (Austenitic stainless steel)	
Max./Min. Operating Pressure		0 ~ 240kPa (0 ~ 34.8psi, 0 ~ 2bar)	
Max./Min. Operating Temperature		10 ~ 137.9°C (50 ~ 280.2° F)	
Sterilization Temperature		115°C ~ 135°C	
Melting Temperature		60°C ~ 114°C	
Heat-retention Temperature		45°C Thermistor, digital display 60°C	
Thermometer		Thermistor, digital display (25°C ~ 141°C)	
Safety Valve Releasing Pressure		240kPa (34.8psi, 2.4bar)	
Pressure Gauge Range		0 ~ 0.4 MPa (0 ~ 43.5psi, 0 ~ 4bar)	
Timer	Sterilization	1 min. ~ 5 hrs.	
	Melting	1 min. ~ 5 hrs.	
	Heat-retent	72 hrs. fixed	
	Timer	1 week (Designation: Year, month, day, hour and minute)	
Exhaust Tank		2 liter polypropylene tank	
Warning and Safety Functions		Pressure safety valve, overheat prevention device, dry-scorch prevention, cover interlock, excessive pressure prevention, earth leakage breaker	
Sound Pressure Level		Max. 70dB (A)	
Accessories		Stainless steel baskets – Large: 1, small: 1	Stainless steel baskets – Large: 2, small: 1
		Drain hose: 1	
		Exhaust tank (1), exhaust hose at rear side (1), tank mounting bracket (1) and tip-resistant metals (3)	
Optional Accessories		Object temperature sensor, external temperature sensor, printer, stainless steel basket (large), stainless steel basket (small), punching basket, sterilization can, floor plate (floor plate that can not be fixed by anchor will be sold with the product in set.) *Please consult us about the model number, price, delivery date, etc. including other optional accessories than shown as above.	

\* The specifications may be subject to change for improvement without prior notice.

## Daily Inspection

Check the cover packing for any crack or flaw. If any crack or flaw is found, immediately stop use of the product and ask your dealer for replacement.



### WARNING



#### Check the cover packing

Sterilization of animal oil and fat (e.g., wastes generated after BSE inspection) causes premature wear, crack or breakage of the cover packings. If the product is used with defective packings, steam may burst out resulting in burn and other accidents.

## Safety Inspection

This product incorporates the inspection display circuit.

This circuit is to display the time to ask your dealer for inspection when the product is used in a certain number of times.

(As for details about inspection including cost, etc., please consult the dealer from whom you purchased the product.)

#### Operation of the inspection display is as follows:

- The frequency of use of this product reaches the preset number of times, “ $\text{EH}$ ” appears and flickers on the digital display **1** and at the same time the buzzer sounds to tell that the time for safety inspection comes when the power switch is set to ON. At this moment, it is impossible to operate other buttons than the stop button.
- To delete the inspection display temporarily, press the  button. However, in the standby status, the inspection display appears again. This condition will go on unless the safety inspection is implemented.

Ask your dealer for the safety inspection ahead of time.

## If something unusual should happen during operation

Stop using the unit immediately, and ask your dealer to inspect and repair it. It is dangerous for the customer to attempt to disassemble and repair the unit. Special technology is required for repair.

## Questions concerning after-sales service

Direct any questions or queries concerning repair service or the unit itself to your dealer or to the manufacturer's customer service representative.

