

EXPAND SERIAL COMMAND
FUNCTIONAL SPECIFICATIONS

PDG-DET100L

Ver.1.00

SANYO Electric Co., Ltd
DS Company
Projector Business Division

CONTENTS

1 . Overview	9
2 . Serial Interface Specification.....	9
2.1 Transfer Specification	9
2.2 Connection	9
3 . Notes for communication.....	10
4 . Notation.....	11
5 . Functional Execution Command Table.....	12
5.1 Image Command Table.....	12
5.2 PC Control Command Table	12
5.3 Input Control Command Table	12
5.4 Screen Command Table	13
5.5 Lamp Command Table	13
5.6 Setting Command Table.....	13
5.7 Other Command Table	14
6 . Status Read Command Table.....	15
6.1 Image Status Read Command Table.....	15
6.2 PC Status Read Command Table	15
6.3 Video Status Read Command Table	15
6.4 Input Status Read Command Table	16
6.5 Screen Status Read Command Table	16
6.6 Lamp Status Read Command Table.....	16
6.7 Setting Status Read Command Table.....	16
6.8 Other Status Read Command Table.....	18
7 . Error Code Table	18
8 . Functional Execution Command.....	19
8.1 Format.....	19
8.2 Transfer Example.....	19
8.3 Operation Requirements.....	19
8.4 Image Command.....	20
8.4.1 CF_ CONT Command.....	20
8.4.2 CF_ BRIGHT Command.....	20
8.4.3 CF_ COLOR Command.....	20
8.4.4 CF_ TINT Command.....	20
8.4.5 CF_ COLMNSAV Command	21
8.4.6 CF_ COLMNLD Command.....	21
8.4.7 CF_ APCTRL Command	21
8.4.8 CF_ COLTEMP Command	21
8.4.9 CF_ WBAL- Command.....	22
8.4.10 CF_ OFFSET- Command	22

8.4.11 CF_SHARP Command	22
8.4.12 CF_GAMMA Command.....	23
8.4.13 CF_NZRED Command	23
8.4.14 CF_PROGV Command.....	23
8.4.15 CF_BCOLOR Command	23
8.4.16 CF_IMAGE Command.....	24
8.4.17 CF_IMAGEADJ Command.....	24
8.5 PC Control Command	25
8.5.1 CF_FSYNC Command.....	25
8.5.2 CF_TDOTS Command.....	25
8.5.3 CF_H-POS Command	25
8.5.4 CF_V-POS Command.....	26
8.5.5 CF_CLAMP Command.....	26
8.5.6 CF_DDOTS Command	26
8.5.7 CF_DLINE Command.....	27
8.5.8 CF_SETPCADJ Command	27
8.5.9 CF_ORGMODE Command.....	27
8.5.10 CF_PCSTORE Command	28
8.5.11 CF_PCMODEFREE Command	28
8.6 Input Control Command.....	29
8.6.1 CF_INPUT Command.....	29
8.6.2 CF_SOURCE Command	29
8.6.3 CF_INPUT1~4 Command.....	29
8.6.4 CF_SYSTEM Command.....	30
8.7 Screen Control Command	32
8.7.1 CF_SCREEN Command.....	32
8.7.2 CF_DZCENT Command	32
8.7.3 CF_KEYSTONE Command	33
8.7.4 CF_KEYSTONEMODE Command.....	33
8.7.5 CF_CEIL Command.....	33
8.7.6 CF_REAR Command.....	34
8.7.7 CF_VSCALE Command	34
8.7.8 CF_VPOS Command.....	34
8.7.9 CF_HSCALE Command.....	35
8.7.10 CF_HPOS Command.....	35
8.8 Lamp Command.....	36
8.8.1 CF_LAMPMODE Command.....	36
8.8.2 CF_AUTOLAMPCTRL Command	36
8.8.3 CF_LAMPLIFECNTRL Command.....	36
8.8.4 CF_LAMPINTERVAL Command.....	36

8.9 Setting Command	37
8.9.1 CF_LANG Command	37
8.9.2 CF_MENUPOSITION Command	37
8.9.3 CF_SIMPLEMENU Command	37
8.9.4 CF_MENUSIZE Command	38
8.9.5 CF_DISP Command	38
8.9.6 CF_BACKGND Command	38
8.9.7 CF_PIP Command	38
8.9.8 CF_PIPMAININP Command	39
8.9.9 CF_PIPSUBINPU Command	39
8.9.10 CF_PIPSIZE Command	40
8.9.11 CF_PIPPOSITION Command	40
8.9.12 CF_PIPFRAMELOCK Command	40
8.9.13 CF_PIPSTORE Command	41
8.9.14 CF_PIPMODEFREE Command	41
8.9.15 CF_PIPRST Command	41
8.9.16 CF_EDGEBLENDING Command	41
8.9.17 CF_BLEND Command	42
8.9.18 CF_BLENDBLK Command	42
8.9.19 CF_BLENDBLKALL Command	42
8.9.20 CF_BLENDTESTPAT Command	43
8.9.21 CF_BLENDRST Command	43
8.9.22 CF_COLORMATCHING Command	43
8.9.23 CF_CMMSXY Command	43
8.9.24 CF_CMMSL Command	44
8.9.25 CF_CMTGXY Command	44
8.9.26 CF_CMTGG Command	44
8.9.27 CF_CMAUTOTESTPAT Command	45
8.9.28 CF_CMRST Command	45
8.9.29 CF_CMSTORE Command	45
8.9.30 CF_CMMSTESTPAT Command	45
8.9.31 CF_CMTGTESTPAT Command	46
8.9.32 CF_CMFDEFAULT Command	46
8.9.33 CF_DYNAMICBLACK Command	46
8.9.34 CF_HDMISETUP Command	46
8.9.35 CF_LOGO Command	47
8.9.36 CF_FANSPEED Command	47
8.9.37 CF_RCODE Command	47
8.9.38 CF_RSENS Command	48
8.9.39 CF_P-MANE Command	48

8.9.40 CF_P-MANETIME Command.....	48
8.9.41 CF_ON-STA Command	49
8.9.42 CF_PJPINCODE Command.....	49
8.9.43 CF_FILH Command.....	49
8.9.44 CF_FILTIMER Command	49
8.9.45 CF_FILCTL Command	50
8.9.46 CF_FILSCRL Command.....	50
8.9.47 CF_TESTPAT Command.....	50
8.9.48 CF_FDEFAULT Command	50
8.9.49 CF_KEYDIS Command	50
8.9.50 CF_SHUTRCPROT Command.....	51
8.9.51 CF_SHUTKEYPROT Command	51
8.9.52 CF_SHUTH Command	51
8.10 Other Command.....	52
8.10.1 CF_KEYEMU Command	52
8.10.2 CF_MENU Command	52
8.10.3 CF_POWER Command	53
8.10.4 CF_FREEZE Command	53
8.10.5 CF_VMUTE Command	53
9 . Status Read Command.....	54
9.1 Format.....	54
9.2 Transfer Example.....	54
9.3 Operation condition.....	54
9.4 Image Status Read Commands	55
9.4.1 CR_CONT Command	55
9.4.2 CR_BRIGHT Command	55
9.4.3 CR_COLOR Command	55
9.4.4 CR_TINT Command	55
9.4.5 CR_APCTRL Command.....	55
9.4.6 CR_COLTEMP Command.....	56
9.4.7 CR_WBAL-R Command.....	56
9.4.8 CR_WBAL-G Command	56
9.4.9 CR_WBAL-B Command.....	56
9.4.10 CR_OFFSET-R Command	56
9.4.11 CR_OFFSET-G Command	56
9.4.12 CR_OFFSET-B Command	57
9.4.13 CR_SHARP Command.....	57
9.4.14 CR_GAMMA Command	57
9.4.15 CR_NZRED Command.....	57
9.4.16 CR_PROGV Command	57

9.4.17 CR_BCOLOR Command.....	58
9.4.18 CR_IMAGE Command	58
9.4.19 CR_IMGGMD Command.....	58
9.5 PC Status Read Commands	59
9.5.1 CR_FSYNC Command	59
9.5.2 CR_TDOTS Command.....	59
9.5.3 CR_H-POS Command.....	59
9.5.4 CR_V-POS Command	59
9.5.5 CR_CLAMP Command.....	59
9.5.6 CR_DDOTS Command.....	60
9.5.7 CR_DLINE Command.....	60
9.5.8 CR_SETPCADJ Command.....	60
9.5.9 CR_ORGMODE Command	61
9.5.10 CR_PCSTORE Command.....	61
9.6 Video Status Read Command.....	62
9.6.1 CR_SERSYS Command.....	62
9.7 Input Read Command.....	63
9.7.1 CR_INPUT Command.....	63
9.7.2 CR_SOURCE Command.....	63
9.7.3 CR_SYSTEM Command	64
9.7.4 CR_SRCINP1 Command.....	65
9.7.5 CR_SRCINP2 Command.....	65
9.7.6 CR_SRCINP3 Command.....	65
9.7.7 CR_SRCINP4 Command.....	66
9.7.8 CR_HMSLOT Command.....	66
9.7.9 CR_NMSLOT1 Command	66
9.7.10 CR_NMSLOT2 Command	66
9.7.11 CR_NMSLOT3 Command	66
9.7.12 CR_NMSLOT4 Command	67
9.7.13 CR_IDSLOT1 Command.....	67
9.7.14 CR_IDSLOT2 Command.....	67
9.7.15 CR_IDSLOT3 Command.....	68
9.7.16 CR_IDSLOT4 Command.....	68
9.8 Screen Status Read Commands	69
9.8.1 CR_SCREEN Command	69
9.8.2 CR_KYSTNMODE Command	69
9.8.3 CR_CEIL Command	69
9.8.4 CR_REAR Command	69
9.8.5 CR_VSCALE Command.....	69
9.8.6 CR_VPOS Command	70

9.8.7 CR_HSCALE Command	70
9.8.8 CR_HPOS Command	70
9.9 Lamp Status Read Commands	71
9.9.1 CR_LAMPREPL Command	71
9.9.2 CR_LAMPMODE Command	71
9.9.3 CR_AUTOLAMPCTRL Command	71
9.9.4 CR_LAMPSTS Command	71
9.9.5 CR_INFLAMP Command	72
9.9.6 CR_PROJH Command	72
9.9.7 CR_HMLAMP Command	72
9.9.8 CR_LAMPH Command	72
9.9.9 CR_LAMPINTERVAL Command	73
9.9.10 CR_LAMPLIFECNTRL Command	73
9.10 Setting Status Read Commands	74
9.10.1 CR_LANG Command	74
9.10.2 CR_SIMPLEMENU Command	74
9.10.3 CR_MENUSIZE Command	74
9.10.4 CR_DISP Command	74
9.10.5 CR_BACKGND Command	75
9.10.6 CR_LOGO Command	75
9.10.7 CR_LOGOLOCK Command	75
9.10.8 CR_FANSPEED Command	75
9.10.9 CR_RCODE Command	75
9.10.10 CR_RSENS Command	76
9.10.11 CR_P-MANE Command	76
9.10.12 CR_P-MANETIME Command	76
9.10.13 CR_ONSTA Command	76
9.10.14 CR_SECURITY Command	76
9.10.15 CR_PJLOCKNOW Command	77
9.10.16 CR_PJLOCMENU Command	77
9.10.17 CR_FILH Command	77
9.10.18 CR_FILCOND Command	77
9.10.19 CR_FILREPL Command	77
9.10.20 CR_FILTIMER Command	78
9.10.21 CR_FILREMAIN Command	78
9.10.22 CR_TESTPAT Command	78
9.10.23 CR_KEYDIS Command	78
9.10.24 CR_SHUTRCPROT Command	79
9.10.25 CR_SHUTKEYPROT Command	79
9.10.26 CR_SHUTH Command	79

9.10.27 CR_PIP Command.....	79
9.10.28 CR_PIPMAININP Command	80
9.10.29 CR_PIPSUBINPU Command	80
9.10.30 CR_PIPSIZE Command	81
9.10.31 CR_PIPFRAMELOCK Command	81
9.10.32 CR_PIPSTORE Command	81
9.10.33 CR_EDGEBLENDING Command	81
9.10.34 CR_EDGEBLENDING Command	82
9.10.35 CR_BLENDBLK Command	82
9.10.36 CR_BLENDTESTPAT Command.....	82
9.10.37 CR_COLORMATCHING Command.....	82
9.10.38 CR_CMMSXY_%1 Command	83
9.10.39 CR_CMMSL_%1 Command.....	83
9.10.40 CR_CMTGXY_%1 Command.....	83
9.10.41 CR_CMTGG_%1 Command.....	84
9.10.42 CR_CMAUTOTESTPAT Command	84
9.10.43 CR_CMMSTESTPAT Command	84
9.10.44 CR_CMTGTESTPAT Command.....	84
9.10.45 CR_DYNAMICBLACK Command.....	85
9.10.46 CR_HDMISETUP Command	85
9.11 Other Status Read Commands	86
9.11.1 CR_STATUS Command.....	86
9.11.2 CR_SIGNAL Command.....	86
9.11.3 CR_VMUTE Command.....	86
9.11.4 CR_FREEZE Command	86
9.11.5 CR_P-TIMER Command.....	87
9.11.6 CR_TEMPWARN Command	87
9.11.7 CR_TEMPFAIL Command.....	88
9.11.8 CR_SERIALNO Command.....	88
9.11.9 CR_SHUTCOND Command	88
10 . Command with Address Specification	89
10.1. Overview	89
10.2. Functional Execution Command with address	89
10.2.1. Format.....	89
10.2.2. When the command pipelining is needed.....	90
10.3. Status Read Command with Address.....	90
10.3.1. Format.....	90

1 . Overview

- This Functional Specification defines communication with Network board for PDG-DET100L.
- Commands are designed to communicate with Network board, but most commands are also available to remote-control a projector through RS-232C from a computer. Therefore, commands are defined as Expand Serial Commands.
- The operation by some commands depends on Optional Board installed in Input Slot of the projector.
- This document assumes that Option Boards are installed.

2 . Serial Interface Specification

2.1 Transfer Specification

Items	Specification
Synchronous System	Asynchronous
Transmission Speed	9600 / 19200
Data Length	8 bit
Parity	N/A
Stop Bit	1
Flow Control	N/A

1) Transmission Speed: initial setting value is 19200

2) Transmission Speed can be changed in Service Mode

2.2 Connection

Dedicated serial cables that come with a projector must be used for the connection between a computer and the projector.

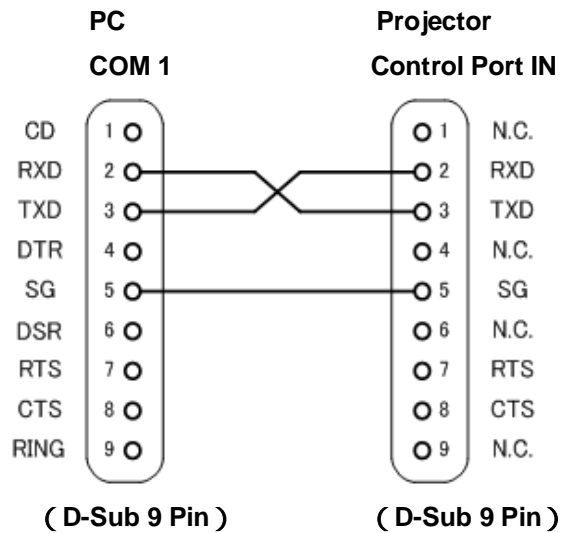

Connect COM port of the computer to SERIAL PORT IN of the projector.

COM Port (COM1 or COM2) of a computer is specified by control software of the computer.

3 . Notes for communication

- Expand Serial Command is defined as a single command per line that starts with “C” and ends with carriage return (0x0D).
- When a projector receives carriage return (0x0D), it starts decoding.
- There are two types of commands as below:
 - Example of Functional Execution Command: “CF_BRIGHT_032” [CR]
 - Example of Status Read Command: “CR_BRIGHT” [CR]
 - Note) “_” indicates a space
- It clears the information of buffer in the following cases:
 - when the projector receives LF (0x0A) or EOF (0x1A).
 - when it takes more than one second to receive a single command
(Until receiving the carriage return after the reception of the first data)
- The projector processes the command and returns the response within a few ms to 8000 ms after the reception of the command. When several commands are sent in succession, do not send another command unless the response to the previous command has been returned. Need to confirm that the processing of the current command has been completed and returned the response before sending another command.

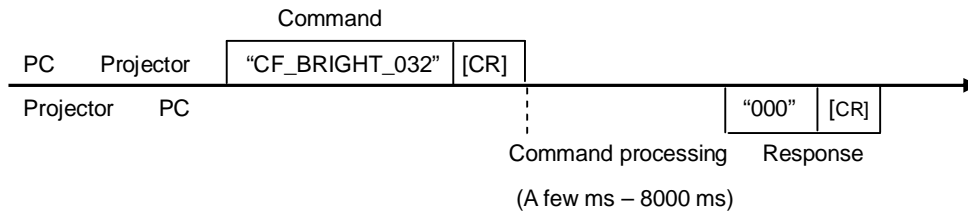

Note) when the computer sends another command before the previous response has been returned, the projector may not operate properly.

Note) when the current command processing has not completed, another command process can not be accepted by the projector

- Normally it is less than 1000ms for the completion of receiving a command and returning the response, but it takes more than 1000ms for some Functional Execution Commands as listed below:

Command	Item
CF_IMAGE	Select Image Mode
CF_INPUT	Select Input
CF_SCREEN	Select Screen Size
CF_SYSTEM	Select System
CF_INPUT1	Select Input 1 and Signal (concurrent execution)
CF_INPUT2	Select Input 2 and Signal
CF_INPUT3	Select Input 3 and Signal
CF_INPUT4	Select Input 4 and Signal
CF_IMAGEADJ	Reset/Store for Image Adjustment

- It takes about 8 seconds for internal initialization after plugging in AC power. During this time it cannot process commands. Do not issue any command.

4 . Notation

- Data from a controller to a projector is represented as COMMAND, and data from a projector to a controller in response to the incoming command is represented as RESPONSE.
- [CR]: Carriage Return Code
The command ends with carriage return code.
The response also ends with carriage return code.
- _: Space Code
All space code is indicated by (_).
- %1: Parameter included in command
When there is more than one parameter, they are represented as %2, %3...

5 . Functional Execution Command Table

5.1 Image Command Table

Execute command	Item
CF_CONT_%1[CR]	Set value of Contrast
CF_BRIGHT_%1[CR]	Set value of Brightness
CF_COLOR_%1[CR]	Set value of Color
CF_TINT_%1[CR]	Set value of Tint
CF_COLMNSAV_%1[CR]	Set area to store current values of Color Management
CF_COLMNLD_%1[CR]	Set area to load values of Color Management
CF_APCTRL_%1[CR]	Set level of Auto Picture Control
CF_COLTEMP_%1[CR]	Set level of Color Temperature
CF_WBAL-R_%1[CR]	Set Red value of White Balance
CF_WBAL-G_%1[CR]	Set Green value of White Balance
CF_WBAL-B_%1[CR]	Set Blue value of White Balance
CF_OFFSET-R_%1 [CR]	Set Red value of Offset
CF_OFFSET-G_%1 [CR]	Set Green value of Offset
CF_OFFSET-B_%1 [CR]	Set Blue value of Offset
CF_SHARP_%1[CR]	Set value of Sharpness
CF_GAMMA_%1[CR]	Set value of Gamma
CF_NZRED_%1[CR]	Set ON/OFF of Noise reduction
CF_PROGV_%1[CR]	Set mode of Progressive scan
CF_BCOLOR_%1[CR]	Set ON/OFF of Brilliant Color
CF_IMAGE_%1[CR]	Set Image mode
CF_IMAGEADJ_%1[CR]	Set Store/Reset of values in Image Adjustment

5.2 PC Control Command Table

Execute command	Item
CF_FSYNC_%1[CR]	Set value of Fine Sync
CF_TDOTS_%1[CR]	Set value of Total Dots
CF_H-POS_%1[CR]	Set value of Horizontal Position
CF_V-POS_%1[CR]	Set value of Vertical Position
CF_CLAMP_%1[CR]	Set value of Clamp
CF_DDOTS_%1[CR]	Set value of Display Dots
CF_DLINE_%1[CR]	Set value of Display Line
CF_SETPCADJ_%1[CR]	Apply values set in PC Adjust menu to screen image
CF_ORGMODE_%1[CR]	Specify the original signal for the selected PC mode
CF_PCSTORE_%1[CR]	Store current setting values in PC Adjust menu to Mode %1
CF_PCMODEFREE_%1 [CR]	Delete the values registered in Mode %1 and return it to Free status.

5.3 Input Control Command Table

Execute command	Item
CF_INPUT_%1[CR]	Select Input
CF_SOURCE_%1[CR]	Select Source of selected Input
CF_INPUT1_%1[CR]	Select Input1 and also set input source to %1
CF_INPUT2_%1[CR]	Select Input2 and also set input source to %1
CF_INPUT3_%1[CR]	Select Input3 and also set input source to %1

CF_INPUT4_%1[CR]	Select Input4 and also set input source to %1
CF_SYSTEM_%1[CR]	Select System in Video input mode

5.4 Screen Command Table

Execute command	Item
CF_SCREEN_%1[CR]	Select Screen size
CF_DZCENT_%1[CR]	Cancel Digital Zoom mode
CF_KEYSTONE_%1[CR]	Set Keystone correction
CF_KYSTNMODE_%1 [CR]	Set Keystone store mode
CF_CEIL_%1[CR]	Set ON/OFF of Ceiling
CF_REAR_%1[CR]	Set ON/OFF of Rear
CF_VSCALE_%1[CR]	Set V Scale
CF_VPOS_%1[CR]	Set V Position
CF_HSCALE_%1[CR]	Set H Scale
CF_HPOS_%1[CR]	Set H Position

5.5 Lamp Command Table

Execute command	Item
CF_LAMPMODE_%1[CR]	Select lamp mode
CF_AUTOLAMPCTRL_%1[CR]	Switch dimmer function levels of Normal/Auto/Eco
CF_LAMPLIFECONTROL_%1[CR]	Select Lamp life control
CF_LAMPINTERVAL_%1[CR]	Set Lamp interval

5.6 Setting Command Table

Execute command	Item
CF_LANG_%1[CR]	Select language for OSD
CF_MENUPOSITION_%1[CR]	Control of Menu position
CF_SIMPLEMENU_%1[CR]	Set ON/OFF of Simple menu
CF_MENUSIZE_%1[CR]	Set Menu size
CF_DISP_%1[CR]	Set ON/OFF of On Screen Display
CF_BACKGND_%1[CR]	Select screen for no signal
CF_PIP_%1[CR]	Set "Picture in Picture"
CF_PIPMAININP_%1_%2[CR]	Select Input and Source of "Picture in Picture" (Main picture)
CF_PIPSUBINP_%1_%2[CR]	Select Input and Source of "Picture in Picture" (Sub picture)
CF_PIPSIZE_&1[CR]	Set menu size of "Picture in Picture"
CF_PIPPOSITION_%1[CR]	Set position of "Picture in Picture"
CF_PIPFRAMELOCK_%1[CR]	Set Frame lock of "Picture in Picture"
CF_PIPSTORE_%1[CR]	Store current status of "Picture in Picture" to User1-5
CF_PIPMODEFREE_%1[CR]	Clear registration contents of User %1 and return to state of Free.
CF_PIPRST_%1[CR]	Reset setting of "Picture in Picture"
CF_EDGEBLENDING_%1[CR]	Set Edge blending
CF_BLEND_%1_%2[CR]	Control width of Edge blending
CF_BLENDBLK_%1_%2[CR]	Control Black level(R/G/B) of Edge blending
CF_BLENDBLKALL_%1_%2[CR]	Control Black level(ALL) of Edge blending
CF_BLENDTESTPAT_%1[CR]	Set Test pattern of Edge blending
CF_BLENDRST_%1[CR]	Reset Edge blending

CF_COLORMATCHING_%1[CR]	Set Color matching
CF_CMMSXY_%1_%2_%3[CR]	Set "x,y" value of Measured of Color matching
CF_CMMSL_%1_%2[CR]	Set "L" value of Measured of Color matching
CF_CMTGXY_%1_%2_%3[CR]	Set "x,y" value of Target of Color matching
CF_CMTGG_%1_%2[CR]	Set "g" value of Target of Color matching
CF_CMAUTOTESTPAT_%1[CR]	Set Auto test pattern of Color matching
CF_CMRST_%1[CR]	Reset Color matching
CF_CMSTORE_%1[CR]	Store Color matching
CF_CMMSTESTPAT_%1[CR]	Display Measured Test pattern of Color matching
CF_CMTGTESTPAT_%1[CR]	Display Target Test pattern of Color matching
CF_CMFDEFAULT_%1[CR]	Return Color matching settings to Factory Default status
CF_DYNAMICBLACK_%1[CR]	Set DynamicBlack
CF_HDMISETUP_%1[CR]	Set HDMI setup
CF_LOGO_%1[CR]	Set ON/OFF of Logo
CF_FANSPEED_%1[CR]	Select Fan Speed
CF_RCODE_%1[CR]	Select Remote Control Code
CF_RSNS_%1[CR]	Select location of infrared remote receiver of remote control
CF_P-MANE_%1[CR]	Set ON/OFF of Power Management
CF_P-MANETIME_%1[CR]	Set time of Power Management
CF_ON-STA_%1[CR]	Set ON/OFF of Power ON Start
CF_PJPINCODE_%1[CR]	Enter PJ PIN code to cancel PJ lock
CF_FILH_%1[CR]	Reset Filter used time
CF_FILTIMER_%1[CR]	Set time to display Filter cleaning / replacement warning on screen
CF_FILCTL_%1[CR]	Execute operation of scroll of filter
CF_FILSCRL_%1[CR]	Reset Filter scroll counter
CF_TESTPAT_%1[CR]	Set Test pattern display function
CF_FDEFAULT_%1[CR]	Return the settings to Factory Default status
CF_KEYDIS_%1[CR]	Set limitation of RC/KEY control
CF_SHUTRCPROT_%1[CR]	Set valid / invalid of RC use on Shutter control function
CF_SHUTKEYPROT_%1[CR]	Set valid / invalid use of key on the top panel on Shutter control function
CF_SHUTH_%1[CR]	Set time of operating shutter management function

5.7 Other Command Table

Execute command	Item
CF_KEYEMU_%1[CR]	Control RC/Panel key operation of Pointer(Right/Left/Top/Bottom)/SELECT/AUTO PC
CF_MENU_%1[CR]	Set ON/OFF of Menu
CF_POWER_%1[CR]	Set ON/OFF of Power
CF_FREEZE_%1[CR]	Set ON/OFF of Freeze
CF_VMUTE_%1[CR]	Control Open/Close of Shutter

6 . Status Read Command Table

6.1 Image Status Read Command Table

Status read command	Item
CR_CONT [CR]	Get value of Contrast
CR_BRIGHT [CR]	Get value of Brightness
CR_COLOR [CR]	Get value of Color
CR_TINT [CR]	Get value of Tint
CR_APCTRL	Get setting status of Auto Picture Control
CR_COLTEMP	Get value of Color temperature
CR_WBAL-R [CR]	Get Red value of White Balance
CR_WBAL-G [CR]	Get Green value of White Balance
CR_WBAL-B [CR]	Get Blue value of White Balance
CR_OFFSET-R [CR]	Get Offset Red
CR_OFFSET-G [CR]	Get Offset Green
CR_OFFSET-B [CR]	Get Offset Blue
CR_SHARP [CR]	Get value of Sharpness
CR_GAMMA [CR]	Get value of Gamma
CR_NZRED [CR]	Get setting status of Noise reduction
CR_PROGV [CR]	Get setting status of Progressive scan
CR_BCOLOR [CR]	Get setting status of BrilliantColor
CR_IMAGE [CR]	Get Selected Image status
CR_IMGGMD [CR]	Get setting value of Image Gamma

6.2 PC Status Read Command Table

Status read command	Item
CR_FSYNC [CR]	Get setting value of Fine Sync
CR_TDOTS [CR]	Get setting value of Total Dots
CR_CLAMP [CR]	Get setting value of Clamp
CR_H-POS [CR]	Get setting value of Horizontal Position
CR_V-POS [CR]	Get setting value of Vertical Position
CR_DDOTS [CR]	Get setting value of Display Dots
CR_DLINE [CR]	Get setting value of Display Line
CR_SETPCADJ [CR]	Get currently displayed signal
CR_ORGMODE [CR]	Get the original signal of the mode adjusted in PC Adj.
CR_PCSTORE [CR]	Get Free or Stored status for PC Adj. Mode 1-5

6.3 Video Status Read Command Table

Status read command	Item
CR_SERSYS [CR]	Get currently selected signal. In Auto mode, it returns a result by Auto detection.

6.4 Input Status Read Command Table

Status read command	Item
CR_INPUT [CR]	Get selected Input
CR_SOURCE [CR]	Get selected Source
CR_SYSTEM [CR]	Get selected System in Video Input mode
CR_SRCINP1 [CR]	Get selected source for Input 1
CR_SRCINP2 [CR]	Get selected source for Input 2
CR_SRCINP3 [CR]	Get selected source for Input 3
CR_SRCINP4 [CR]	Get selected source for Input 4
CR_HMSLOT [CR]	Get the total number of Slots
CR_NMSLOT1 [CR]	Get a card name inserted to Slot 1
CR_NMSLOT2 [CR]	Get a card name inserted to Slott2
CR_NMSLOT3 [CR]	Get a card name inserted to Slot 3
CR_NMSLOT4 [CR]	Get a card name inserted to Slot 4
CR_IDSLOT1 [CR]	Get ID information of Slot 1
CR_IDSLOT2 [CR]	Get ID information of Slot 2
CR_IDSLOT3 [CR]	Get ID information of Slot 3
CR_IDSLOT4 [CR]	Get ID information of Slot 4

6.5 Screen Status Read Command Table

Status read command	Item
CR_SCREEN [CR]	Get selected screen size
CR_KYSTNMODE[CR]	Get selected Keystone store mode
CR_CEIL[CR]	Get selected ON/OFF of Ceiling
CR_REAR[CR]	Get selected ON/OFF of Rear
CR_VSCALE[CR]	Get setting status of V Scale
CR_VPOS[CR]	Get setting status of V Position
CR_HSCALE[CR]	Get setting status of H Scale
CR_HPOS[CR]	Get setting status of H Position

6.6 Lamp Status Read Command Table

Status read command	Item
CR_LAMPREPL [CR]	Get information on Lamp replacement time
CR_LAMPMODE [CR]	Get selected Lamp mode
CR_AUTOLAMPCONTROL[CR]	Get setting status of dimmer function level.
CR_LAMPSTS [CR]	Get Lamp lighting status
CR_INFLAMP [CR]	Get Lamp switching status
CR_PROJH [CR]	Get the projector total running time
CR_HMLAMP [CR]	Get the total number of lamps
CR_LAMPH [CR]	Get information of actual Lamp running time
CR_LAMPINTERVAL [CR]	Get Lamp interval status
CR_LAMPLIFECONTROL [CR]	Get Lamp life control status

6.7 Setting Status Read Command Table

Status read command	Item
CR_LANG [CR]	Get selected language
CR_SIMPLEMENU [CR]	Get setting status of Simple menu

CR_MENUSIZE [CR]	Get setting status of Menu size
CR_DISP [CR]	Get setting status of Display
CR_BACKGND [CR]	Get setting status of Screen for no signal
CR_LOGO [CR]	Get setting status of Logo
CR_LOGOLOCK [CR]	Get setting status of Logo Lock
CR_FANSPEED [CR]	Get selected Fan Control Speed
CR_RCODE [CR]	Get selected Remote Control Code
CR_RSENS [CR]	Get selected location of infrared remote receiver of remote control
CR_P-MANE [CR]	Get setting status of Power management
CR_P-MANETIME [CR]	Get setting time for Power Management
CR_ON-STA [CR]	Get setting status of ON Start
CR_SECURITY [CR]	Get setting status of Security
CR_PJLOCKNOW [CR]	Get setting status of current PJ Lock
CR_PJLOCKMENU [CR]	Get PJ Lock setting status on the menu
CR_FILH[CR]	Get Filter used time
CR_FILCOND[CR]	Get status of filter clog
CR_FILREPL[CR]	Get status of Filter cleaning / replacement time
CR_FILTIMER[CR]	Get time to display Filter cleaning / replacement warning on screen
CR_FILREMAIN[CR]	Get remaining number of usable Filter scroll
CR_TESTPAT[CR]	Get setting status of Test pattern
CR_KEYDIS [CR]	Get setting status of RC/KEY control limitation
CR_SHUTRCPROT[CR]	Get remote controller disability status of the shutter
CR_SHUTKEYPROT[CR]	Get Key controller disability state of the shutter
CR_SHUTH[CR]	Get time setting to begin the shutter management
CR_PIP[CR]	Get setting status of "Picture in Picture"
CR_PIPMAININP[CR]	Get setting status of Input / Source of "Picture in Picture" (Main picture)
CR_PIPSUBINP[CR]	Get setting status of Input / Source of "Picture in Picture" (Sub picture)
CR_PIPSIZE[CR]	Get Menu size of "Picture in Picture"
CR_PIPFRAMELOCK[CR]	Get setting status of Frame lock of "Picture in Picture"
CR_PIPSTORE[CR]	Get stored status of "Picture in Picture"
CR_EDGEBLENDING[CR]	Get setting status of Edge blending
CR_BLEND[CR]	Get setting status of width of Edge blending
CR_BLENDBLK[CR]	Get setting status of Black level of Edge blending
CR_BLENDTESTPAT[CR]	Get setting status of Test pattern of Edge blending
CR_COLORMATCHING[CR]	Get setting status of Color matching
CR_CMMSXY_%1[CR]	Get "x","y" value of Measured of Color matching
CR_CMMSL_%1[CR]	Get "L" value of Measured of Color matching
CR_CMTGXY_%1[CR]	Get "x","y" value of Target of Color matching
CR_CMTGG_%1[CR]	Get "g" value of Target of Color matching
CR_CMAUTOTESTPAT[CR]	Get setting status of Auto test pattern of Color matching
CR_CMMSTESTPAT[CR]	Get setting status of test pattern(Measured) of Color matching
CR_CMTGTESTPAT[CR]	Get setting status of test pattern(Target) of Color matching
CR_DYNAMICBLACK[CR]	Get setting status of DynamicBlack
CR_HDMISETUP[CR]	Get setting status of HDMI setup

6.8 Other Status Read Command Table

Status read command	Item
CR_STATUS [CR]	Get operation state of the projector
CR_SIGNAL [CR]	Get status of signal existence
CR_VMUTE [CR]	Get setting status of Video mute
CR_FREEZE [CR]	Get setting status of Freeze
CR_PTIMER [CR]	Get operating status of P-Timer
CR_TEMPWARN [CR]	Get temperature status whether it is close to abnormal level or not
CR_TEMPFAIL [CR]	Get temperature in abnormal temperature status
CR_SERIALNO [CR]	Get value of Serial number
CR_SHUTCOND [CR]	Get setting status of Shutter

7 . Error Code Table

Error Code	Contents
?	-When the received data cannot be decoded -Parameter designation error (wrong digit number, including invalid value, etc.)
000	Normal reception (This is "Not" error)
101	Specified function is not available in the selected mode
102	Specified value is out of range (Not reflected)
103	Command mismatched to Hardware (the command is for Optional function which is not implemented)
201	Incremented or decremented value or values are beyond upper or lower limits.
301	Not executable due to screen capturing in process. Prompting reissue of the command after a while.
402	Not executable due to PIN code in operation. Prompting reissue of the command after a while.

8 . Functional Execution Command

8.1 Format

1) PC issues a command in the format below:

Pattern1: "CF_ Command" [CR]

Pattern2: "CF_ Command_" %1 [CR]

CF_: Header

Command: String

%1: Parameter (String)

_ : Space (To separate Command and Parameter)

2) The projector decodes the received command and when it gets ready to receive another command, it returns the response.

"000" [CR]: (0x06, 0x0D) When receiving Functional Execution Command

"nnn" [CR]: Except "000", when it cannot execute commands for any specific reason.

For detail, refer to [7. Error Code Table]

"?" [CR]: When the received data cannot be decoded

8.2 Transfer Example

When setting projector's total dots to 1344 by Expand Command.

PC → PJ: "CF_TDOTS_1344" [CR]

PC ← PJ: "000" [CR] ----- Acceptable

8.3 Operation Requirements

When the projector status is in the status below, Functional Execution Commands are limited
(Status Read Commands are available in following status)

Projector Status	Available Functional Execution Command
In Standby Mode	C00: POWER ON
Count Down in process	C00: POWER ON (Countdown is terminated)
Cooling Down in process	NONE (No Execution)
Cooling Down in process due to abnormal temperature	NONE (No Execution)
In Abnormal Temperature	NONE (No Execution)
Power Failure (60 seconds after Power failed)	NONE (No Execution)
Power Saving Cooling Down in process	NONE (No Execution)
In Power Saving status	C00: POWER ON C01: POWER OFF

Note) An appropriate error code is returned when the projector receives other command in the above status.

8.4 Image Command

8.4.1 CF_CONT Command

Command	"CF_CONT_%1" [CR]	
%1	"000-063"----- Directly specify setting value of Contrast "UP"----- Increment setting value of Contrast by 1 "DN"----- Decrement setting value of Contrast by 1	
Details	Set user controlled value of Contrast. (Available only in the normal Power ON status) The value set by this command is not stored in the projector. Therefore, when the power is turned to ALL OFF status, the value returns to the original setting. (It is stored in Suspend mode.)	
Response	Acceptable	"000" [CR]
	Unacceptable	"Error Code" [CR]

8.4.2 CF_BRIGHT Command

Command	"CF_BRIGHT_%1" [CR]	
%1	"000-063" ----- Directly specify setting value of Brightness "UP" ----- Increment setting value of Brightness by 1 "DN" ----- Decrement setting value of Brightness by 1	
Details	Set user controlled value of Brightness. (Available only in the normal Power ON status) The value set by this command is not stored in the projector's memory. Therefore, when the power is turned to ALL OFF status, the value returns to the original setting. (It is stored in Suspend mode.)	
Response	Acceptable	"000" [CR]
	Unacceptable	"Error Code" [CR]

8.4.3 CF_COLOR Command

Command	"CF_COLOR_%1" [CR]	
%1	"000-063"----- Directly specify setting value of Color "UP"----- Increment setting value of Color by 1 "DN"----- Decrement setting value of Color by 1	
Details	Set user controlled value of Color. (Available only in the normal Power ON status) The value set by this command is not stored in the projector's memory. Therefore, when the power is turned to ALL OFF status, the value returns to the original setting. (It is stored in Suspend mode.)	
Response	Acceptable	"000" [CR]
	Unacceptable	"Error Code" [CR]

8.4.4 CF_TINT Command

Command	"CF_TINT_%1" [CR]	
%1	"000-063"----- Directly specify setting value of Tint "UP"----- Increment setting value of Tint by 1 "DN"----- Decrement setting value of Tint by 1	
Details	Set user controlled value of Tint (Available only in the normal Power ON status) The value set by this command is not stored in the projector's memory. Therefore, when the power is turned to ALL OFF status, the value returns to the original setting. (It is stored in Suspend mode.)	
Response	Acceptable	"000" [CR]
	Unacceptable	"Error Code" [CR]

8.4.5 CF_COLMNSAV Command

Command	"CF_COLMNSAV_%1" [CR]	
%1	"000 – 009" ----- Specify the area to store	
Details	Store current setting status of Color Management to the area specified in %1. (Available only in the normal Power ON status)	
Response	Acceptable	"000" [CR]
	Unacceptable	"Error Code" [CR]

8.4.6 CF_COLMNL D Command

Command	"CF_COLMNL D_%1" [CR]	
%1	"000 – 009" ----- Specify the area to store	
Details	Retrieve Color Management setting status from the area specified in %1. (Available only in the normal Power ON status)	
Response	Acceptable	"000" [CR]
	Unacceptable	"Error Code" [CR]

8.4.7 CF_APCTRL Command

Command	"CF_APCTRL_%1" [CR]	
%1	"L1" ----- Set Auto Picture Control to Level 1. "L2" ----- Set Auto Picture Control to Level 2. "OFF" ----- Set Auto Picture Control OFF. "UP" ----- Switch setting forward direction (OFF→L1→L2→OFF) "DN" ----- Switch setting backward direction (OFF→L2→L1→OFF)	
Details	Set Auto Picture Control (Available only in the normal Power ON status) The value set by this command is not stored in the projector's memory. Therefore, when the power is turned to ALL OFF status, the value returns to the original setting. (It is stored in Suspend mode.)	
Response	Acceptable	"000" [CR]
	Unacceptable	"Error Code" [CR]

8.4.8 CF_COLTEMP Command

Command	"CF_COLTEMP_%1" [CR]	
%1	"000" ----- XLow "001"----- Low "002"----- Mid "003"----- High "CLEAR"----- Clear base "BLUE" ----- Blue base	
Details	Set Color Temperature (Available only in the normal Power ON status) The value set by this command is not stored in the projector's memory. Therefore, when the power is turned to ALL OFF status, the value returns to the original setting. (It is stored in Suspend mode.)	
Response	Acceptable	"000" [CR]
	Unacceptable	"Error Code" [CR]

8.4.9 CF_WBAL- Command

Command	"CF_WBAL-%1_%2" [CR]	
%1	"R" ----- RED "G" ----- GREEN "B" ----- BLUE	
%2	"000-063"----- Directly specify value of Color selected in %1 of White Balance. "UP"----- Increment setting value of Color specified in %1 of White Balance by 1 "DN"----- Decrement setting value of Color specified in %1 of White Balance by 1	
Details	Set value of Color specified in %1 of White Balance (Available only in the normal Power ON status) The value set by this command is not stored in the projector's memory. Therefore, when the power is turned to ALL OFF status, the value returns to the original setting. (It is stored in Suspend mode.)	
Response	Acceptable	"000" [CR]
	Unacceptable	"Error Code" [CR]

8.4.10 CF_OFFSET- Command

Command	"CF_OFFSET-%1_%2" [CR]	
%1	"R" ----- RED "G" ----- GREEN "B" ----- BLUE	
%2	"000-063"----- Directly specify value of Color selected in %1 of Offset. "UP"----- Increment setting value of Color specified in %1 of Offset by 1 "DN"----- Decrement setting value of Color specified in %1 of Offset by 1	
Details	Set value of Color specified in %1 of Offset (Available only in the normal Power ON status) The value set by this command will not be stored in the projector's memory. Therefore, when the power is turned to ALL OFF status, the value returns to the original setting. (It is stored in Suspend mode.)	
Response	Acceptable	"000" [CR]
	Unacceptable	"Error Code"[CR]

8.4.11 CF_SHARP Command

Command	"CF_SHARP_%1" [CR]	
%1	"000-031" ----- Directly specify setting value of Sharpness. "UP"----- Increment setting value of Sharpness by 1 "DN"----- Decrement setting value of Sharpness by 1	
Details	Set user controlled value of Sharpness. (Available only in the normal Power ON status) The value set by this command is not stored in the projector's memory. Therefore, when the power is turned to ALL OFF status, the value returns to the original setting. (It is stored in Suspend mode.)	
Response	Acceptable	"000" [CR]
	Unacceptable	"Error Code" [CR]

8.4.12 CF_GAMMA Command

Command	"CF_GAMMA_%1" [CR]	
%1	"000-015" ----- Directly specify setting value of Gamma "UP"----- Increment setting value of Gamma by 1 "DN"----- Decrement setting value of Gamma by 1	
Details	Set user controlled value of Gamma. (Available only in the normal Power ON status) The value set by this command is not stored in the projector's memory. Therefore, when the power is turned to ALL OFF status, the value returns to the original setting. (It is stored in Suspend mode.)	
Response	Acceptable	"000" [CR]
	Unacceptable	"Error Code" [CR]

8.4.13 CF_NZRED Command

Command	"CF_NZRED_%1" [CR]	
%1	"ON" ----- Set Noise Reduction to ON "OFF" ----- Set Noise Reduction to OFF	
Details	Set or Cancel Noise Reduction. (Available only in the normal Power ON status) The value set by this command is not stored in the projector's memory. Therefore, when the power is turned to ALL OFF status, the value returns to the original setting. (It is stored in Suspend mode.)	
Response	Acceptable	"000" [CR]
	Unacceptable	"Error Code" [CR]

8.4.14 CF_PROGV Command

Command	"CF_PROGV_%1" [CR]	
%1	"ON" ----- Set Progressive scan to ON "FILM" ----- Set Progressive scan to Film mode "OFF" ----- Set Progressive scan to OFF	
Details	Set or Cancel Progressive scan. (Valid only when it is in the normal Power ON status.) The value set by this command is not stored in the projector's memory. Therefore, when the power is turned to ALL OFF status, the value returns to the original setting. (It is stored in Suspend mode.)	
Response	Acceptable	"000" [CR]
	Unacceptable	"Error Code" [CR]

8.4.15 CF_BCOLOR Command

Command	"CF_BCOLOR_%1" [CR]	
%1	"ON" ----- Set BrilliantColor to ON "OFF" ----- Set BrilliantColor to OFF	
Details	Set or Cancel BrilliantColor.	
Response	Acceptable	"000" [CR]
	Unacceptable	"Error Code" [CR]

8.4.16 CF_IMAGE Command

Command	"CF_IMAGE_%1" [CR]	
%1	<p>"STAND" ----- Standard (Image adjustment value is set to factory default)</p> <p>"REAL" ----- Real (Fixed value to display graphic image with natural tone)</p> <p>"CINEMA" ----- Cinema (Fixed value to focus on tone reproduction for movie)</p> <p>"DYNAMIC"----- Dynamic (Fixed value to enable projection with a sharp, powerful picture tone)</p> <p>"DICOM" ----- DICOM (Fixed value to be based in DICOM Part14 Grayscale Standard)</p> <p>"CUSTOM1" ----- Image1 (values adjusted and stored by user)</p> <p>"CUSTOM2" ----- Image2 (values adjusted and stored by user)</p> <p>"CUSTOM3" ----- Image3 (values adjusted and stored by user)</p> <p>"CUSTOM4" ----- Image4 (values adjusted and stored by user)</p> <p>"CUSTOM5" ----- Image5 (values adjusted and stored by user)</p> <p>"CUSTOM6" ----- Image6 (values adjusted and stored by user)</p> <p>"CUSTOM7" ----- Image7 (values adjusted and stored by user)</p> <p>"CUSTOM8" ----- Image8 (values adjusted and stored by user)</p> <p>"CUSTOM9" ----- Image9 (values adjusted and stored by user)</p> <p>"CUSTOM10" -----Image10 (values adjusted and stored by user)</p>	
Details	<p>Select Image mode. (Valid only when it is in the normal Power ON status.)</p> <p>Parameter "CUSTOM1" to "CUSTOM10" corresponds to "Image1" to "Image10" displayed in projector OSD menu on selecting Image.</p> <p>The value set by this command is stored in EEPROM so that the setting can remain effective even after the power is turned to ALL OFF status.</p>	
Response	Acceptable	"000" [CR]
	Unacceptable	"Error Code" [CR]

8.4.17 CF_IMAGEADJ Command

Command	"CF_IMAGEADJ_%1"[CR]	
%1	<p>"RST"----- Reset adjusted value for the Image</p> <p>"STR1"---- Store current adjusted value to Image 1</p> <p>"STR2"---- Store current adjusted value to Image 2</p> <p>"STR3"---- Store current adjusted value to Image 3</p> <p>"STR4"---- Store current adjusted value to Image 4</p> <p>"STR5"---- Store current adjusted value to Image 5</p> <p>"STR6"---- Store current adjusted value to Image 6</p> <p>"STR7"---- Store current adjusted value to Image 7</p> <p>"STR8"---- Store current adjusted value to Image 8</p> <p>"STR9"---- Store current adjusted value to Image 9</p> <p>"STR10"--- Store current adjusted value to Image 10</p>	
Details	<p>Reset or Store adjusted value for Image. (Available only in the normal Power ON status)</p> <p>"STR1"- "STR10" corresponds to "Image1"- "Image10" displayed in projector OSD menu on selecting "Store" for adjusted value of Image. The setting value set in "Image1" to "Image10" is stored and can be retrieved when turning on the projector again after the power is turned to ALL OFF status.</p>	
Response	Acceptable	"000" [CR]
	Unacceptable	"Error Code" [CR]

8.5 PC Control Command

8.5.1 CF_FSYNC Command

Command	"CF_FSYNC_%1" [CR]	
%1	"0000-0031" ----- Directly specify setting value of Fine Sync "UP" ----- Increment setting value of Fine Sync by 1 "DN" ----- Decrement setting value of Fine Sync by 1	
Details	Set value of Fine Sync in PC signal (Available only in the normal Power ON status) The value set by this command is not stored in the projector's memory. Therefore, when the power is turned to ALL OFF status, the value returns to the original setting. (It is stored in Suspend mode.)	
Response	Acceptable	"000" [CR]
	Unacceptable	"101" [CR] --- When input is Video signal --- When input is no signal

8.5.2 CF_TDOTS Command

Command	"CF_TDOTS_%1" [CR]	
%1	"mmmm – nnnn" ----- Directly specify setting value of Total Dots "mmmm" indicates minimum value, which is current (Display Area H + Position H) value "nnnn" indicates maximum value, that dot clock does not exceed more than 160MHz. "UP" ----- Increment setting value of Total Dots by 1 "DN" ----- Decrement setting value of Total Dots by 1	
Details	Set value of Total Dots in PC signal (Available only in the normal Power ON status) The value set by this command is not stored in the projector's memory. Therefore, when the power is turned to ALL OFF status, the value returns to the original setting. (It is stored in Suspend mode.)	
Response	Acceptable	"000" [CR]
	Unacceptable	"101" [CR] --- When input is Video signal --- When input is no signal

8.5.3 CF_H-POS Command

Command	"CF_H-POS_%1" [CR]	
%1	"0000-nnnn" ----- Directly specify setting value of Horizontal Position "nnnn" indicates maximum value, which is current value of (Total Dots – Display Area H) "UP" ----- Increment setting value of Horizontal Position by 1 "DN" ----- Decrement setting value of Horizontal Position by 1	
Details	Set value of Horizontal Position in PC signal (Available only in the normal Power ON status) The value set by this command is not stored in the projector's memory. Therefore, when the power is turned to ALL OFF status, the value returns to the original setting. (It is stored in Suspend mode.)	
Response	Acceptable	"000" [CR]
	Unacceptable	"101" [CR] --- When input is Video signal --- When input is no signal

8.5.4 CF_V-POS Command

Command	"CF_V-POS_%1" [CR]	
%1	"0000-nnnn" ----- Directly specify setting value of Vertical Position "nnnn" indicates maximum value, which is current (Total Line – Display Area V) value "UP" ----- Increment setting value of Vertical Position by 1 "DN" ----- Decrement setting value of Vertical Position by 1	
Details	Set Vertical Position value in PC signal (Available only in the normal Power ON status) The value set by this command is not stored in the projector's memory. Therefore, when the power is turned to ALL OFF status, the value returns to the original setting. (It is stored in Suspend mode.)	
Response	Acceptable	"000" [CR]
	Unacceptable	"101" [CR] --- When input is Video signal --- When input is no signal

8.5.5 CF_CLAMP Command

Command	"CF_CLAMP_%1" [CR]	
%1	"0000-4095" ----- Directly specify setting value of Clamp "UP" ----- Increment setting value of Clamp by 1 "DN" ----- Decrement setting value of Clamp by 1	
Details	Set Clamp value in PC signal. (Available only in the normal Power ON status) The value set by this command will not be stored in the projector's memory. Therefore, when the power is turned to ALL OFF status, the value returns to the original setting. (It is stored in Suspend mode.)	
Response	Acceptable	"000" [CR]
	Unacceptable	"101" [CR] --- When input is Video signal --- When input is no signal

8.5.6 CF_DDOTS Command

Command	"CF_DDOTS_%1" [CR]	
%1	"0256-nnnn" ----- Directly specify setting value of Display Dots "nnnn" indicates maximum value, which is current value of (Total Dots - Position H). H). In this projector, the value should be "even number" and if "odd number" is specified, it adds 1 to make the value even number. "UP" ----- Increment setting value of Display Dots by 2 "DN" ----- Decrement setting value of Display Dots by 2	
Details	Set Display Dots value in PC signal. (Available only in the normal Power ON status) The value set by this command is not stored in the projector's memory. Therefore, when the power is turned to ALL OFF status, the value returns to the original setting. (It is stored in Suspend mode.)	
Response	Acceptable	"000" [CR]
	Unacceptable	"101" [CR] --- When input is Video signal --- When input is no signal

8.5.7 CF_DLINE Command

Command	"CF_DLINE_%1" [CR]	
%1	"0100-nnnn" ----- Directly specify setting value of Display Line "nnnn" indicates maximum value, which is current value of (Total Line - Position V). "UP" ----- Increment setting value of Display Line by 1 "DN" ----- Decrement setting value of Display line by 1	
Details	Set setting value of Display Line in PC signal (Available only in the normal Power ON status) The value set by this command is not being stored in the projector's memory. Therefore, when the power is turned to ALL OFF status, the value returns to the original setting. (It is stored in Suspend mode.)	
Response	Acceptable	"000" [CR]
	Unacceptable	"101" [CR] --- When input is Video signal --- When input is no signal

8.5.8 CF_SETPCADJ Command

Command	"CF_SETPCADJ_%1" [CR]	
%1	"XGA1", "HDTV1080", "MODE1"Etc. "EXT11"~"EXT60"	
Detail	Note1) When "XGA", "HDTV1080", "MODE1" is specified in %1, the command is not executed. Note2) When "EXTn-EXTnn" (nn represents number) is specified in %1, "EXT" is displayed in "SYSTEM" menu (only when Network board is provided).	
Response	Acceptable	"000" [CR]
	Unacceptable	"101" [CR] --- When input is Video signal

8.5.9 CF_ORGMODE Command

Command	"CF_ORGMODE_%1" [CR]	
%1	When input signal is PC Analog; "VGA1" ----- Specify VGA1 "VGA2" ----- Specify VGA2 : "XGA1" ----- Specify XGA1 : "WXGA3" ----- Specify WXGA3 "1080i60" ----- Specify 1080i60 "1080i50" ----- Specify 1080i50 "1035i" ----- Specify 1035i "720p60" ----- Specify 720p60 "720p50" ----- Specify 720p50 "575p" ----- Specify 575p "480p" ----- Specify 480p "575i" ----- Specify 575i "480i" ----- Specify 480i "1080psf/24" ----- Specify 1080psf/24 "1080psf/25" ----- Specify 1080psf/25 "1080psf/30" ----- Specify 1080psf/30 "1080p24" ----- Specify 1080p24 "1080p25" ----- Specify 1080p25 "1080p30" ----- Specify 1080p30 "1080p50" ----- Specify 1080p50 "1080p60" ----- Specify 1080p60 * When input signal is not PC Analog, error code "101" is returned.	
Details	After "EXT n" is set by PC control command such as CF_FSYNC/CF_TDOTS and CF_SETPCADJ command, specify the signal originated with by issuing this command. This command is used to specify projector internal settings such as whether or not	

	to get PC signal through IP (Available only in the normal Power ON status) Note; To differentiate between 60Hz and 50Hz in 1080i and 720p, "60" or "50" is necessary to add to the parameter in this command.	
Response	Acceptable	"000" [CR]
	Unacceptable	"101" [CR] --- When input is Video signal

8.5.10 CF_PCSTORE Command

Command	"CF_PCSTORE_%1" [CR]	
%1	"MODE1" ----- Store current PC Adjust status to Mode1 "MODE2" ----- Store current PC Adjust status to Mode2 "MODE3" ----- Store current PC Adjust status to Mode3 "MODE4" ----- Store current PC Adjust status to Mode4 "MODE5" ----- Store current PC Adjust status to Mode5 "MODE6" ----- Store current PC Adjust status to Mode6 "MODE7" ----- Store current PC Adjust status to Mode7 "MODE8" ----- Store current PC Adjust status to Mode8 "MODE9" ----- Store current PC Adjust status to Mode9 "MODE10" ----- Store current PC Adjust status to Mode10	
Details	Store current value of PC Adjust (each parameter status such as Total dots) to Mode1-10. This command operates the same way as storing to Mode1-10 in PC Adjust Menu. (Available only in the normal Power ON status)	
Response	Acceptable	"000" [CR]
	Unacceptable	"101" [CR] --- When input is except PC analog signal

8.5.11 CF_PCMODEFREE Command

Command	"CF_PCMODEFREE_%1" [CR]	
%1	"MODE1" ----- Set Mode1 to Free status "MODE 2" ----- Set Mode2 to Free status "MODE 3" ----- Set Mode3 to Free status "MODE 4" ----- Set Mode4 to Free status "MODE 5" ----- Set Mode5 to Free status "MODE 6" ----- Set Mode6 to Free status "MODE 7" ----- Set Mode7 to Free status "MODE 8" ----- Set Mode8 to Free status "MODE 9" ----- Set Mode9 to Free status "MODE 10" ----- Set Mode10 to Free status	
Details	Delete the data registered in Custom Mode1–10 and returns it to Free status. This command operates the same way as resetting to Mode1-10 in PC Adjust Menu. (Available only in the normal Power ON status)	
Response	Acceptable	"000" [CR]
	Unacceptable	"101" [CR] --- When input is Video signal --- When input is no signal

8.6 Input Control Command

8.6.1 CF_INPUT Command

Command	"CF_INPUT_%1" [CR]	
%1	"1" ----- Select Input 1 "2" ----- Select Input 2 "3" ----- Select Input 3 "4" ----- Select Input 4 "UP"----- Increment Input No. by 1 "DN"----- Decrement Input No. by 1	
Details	Select Input (Only valid when it is in the normal Power ON status.) This command works the same way as "INPUT" button of the projector and remote control.	
Response	Acceptable	"000" [CR]
	Unacceptable	"Error Code" [CR]

8.6.2 CF_SOURCE Command

Command	"CF_SOURCE_%1" [CR]	
%1	"DIGITAL" ----- Select DVI Input "ANALOG" ----- Select Analog Input "VIDEO" ----- Select Composite Video Input "S-VIDEO" ----- Select S-Video input "YPBPR" ----- Select Y/Pb/Pr Input "YCBCR" ----- Select Y/Cb/Cr Input "SDI1" ----- Select SDI 1 Input "SDI2" ----- Select SDI 2 Input "SCART" ----- Select SCART Input "HDCP" ----- Select HDCP Input "HDMI" ----- Select HDMI Input	
Details	Select source of the currently selected Input. (Valid only when in the normal Power ON status.) When selected Input does not meet the requirement for the specified %1, return "101" [CR] and the command is not executed.	
Response	Acceptable	"000" [CR]
	Unacceptable	"Error Code" [CR]

8.6.3 CF_INPUT1~4 Command

Command	"CF_INPUT%1_%2" [CR]	
%1	"1" ----- Specify Input 1 "2" ----- Specify Input 2 "3" ----- Specify Input 3 "4" ----- Specify Input 4	
%2	"DIGITAL" ----- Select DVI Input (Computer signal) "ANALOG" ----- Select Analog Input (Computer signal) "VIDEO" ----- Select Composite Video Input "S-VIDEO" ----- Select S-Video input "YPBPR" ----- Select Y/Pb/Pr Input "YCBCR" ----- Select Y/Cb/Cr Input "SDI1" ----- Select DF-SDI 1 Input "SDI2" ----- Select DF-SDI 2 Input "HDCP" ----- Select HDCP Input "SCART" ----- Select SCART Input "HDMI" ----- Select HDMI Input	
Details	Select Input specified by %1, and also Source specified by %2 concurrently. (Valid only when in the normal Power ON status.)	
Response	Acceptable	"000" [CR]

	Unacceptable	"Error Code" [CR]
--	--------------	-------------------

8.6.4 CF_SYSTEM Command

Command	"CF_SYSTEM_%1" [CR]	
%1	Input is PC Analog	"VGA1" ----- Select VGA1 "VGA2" ----- Select VGA2 : : "XGA1" ----- Select XGA1 : : "WXGA3" ----- Select WXGA3 "1080I" ----- Select 1080i "1035I" ----- Select 1035i "720p" ----- Select 720p "575p" ----- Select 575p "480p" ----- Select 480p "575I" ----- Select 575i "480I" ----- Select 480i "1080psf/24" ----- Select 1080psf/24 "1080psf/25" ----- Select 1080psf/25 "1080psf/30" ----- Select 1080psf/30 "MODE1 - 10" ----- Select MODE1 – MODE10 "EXT11 - 60" ----- Select Ex Mode11-60 * EXT1-10 is not set.
	Input is PC Digital/AV HDCP	"D-XGA1" ----- Select D-XGA1 : : "D-WXGA3" ----- Select D-WXGA3 "D-1080I" ----- Select D-1080i "D-1035I" ----- Select D-1035i "D-720p" ----- Select D-720p "D-575p" ----- Select D-575p "D-480p" ----- Select D-480p "D-1080psf/24" ----- Select D-1080psf/24 "D-1080psf/25" ----- Select D-1080psf/25 "D-1080psf/30" ----- Select D-1080psf/30
	Input is HDMI	"D-XGA1" ----- Select D-XGA1 : : "D-WXGA3" ----- Select D-WXGA3 "D-1080I" ----- Select D-1080i "D-1035I" ----- Select D-1035i "D-720p" ----- Select D-720p "D-575p" ----- Select D-575p "D-480p" ----- Select D-480p
	Input is Y,Pb/Cb,Pr/Cr	"AUTO" ----- Select System "Auto" "1080I" ----- Select 1080i "1035I" ----- Select 1035i "720P" ----- Select 720p "575P" ----- Select 575p "480P" ----- Select 480p "575I" ----- Select 575i "480I" ----- Select 480i
	Input is Video / S-Video	"AUTO" ----- Select System "Auto" "NTSC" ----- Select NTSC "NTSC443" ----- Select NTSC4.43 "PAL" ----- Select PAL "SECAM" ----- Select SECAM "PAL-M" ----- Select PAL-M "PAL-N" ----- Select PAL-N

	Input is Dual-SDI	"D-480I" ----- Select D-480i "D-575I" ----- Select D-575i "D-1035I" ----- Select D-1035i "D-1080I" ----- Select D-1080i "D-720P" ----- Select D-720p "D-1080P" ----- Select D-1080p "D-1080PSF/24" ----- Select D-1080psf/24 "D-1080PSF/25" ----- Select D-1080psf/25 "D-1080PSF/30" ----- Select D-1080psf/30
Details	Select System of currently selected Input (Available only in the normal Power ON status) When selected input does not include specified %1, error code "101" [CR] is returned and it is not executed.	
Response	Acceptable	"000" [CR]
	Unacceptable	"Error Code" [CR]

8.7 Screen Control Command

8.7.1 CF_SCREEN Command

Command	"CF_SCREEN_%1" [CR]	
%1	Input is PC signal	"NORMAL" ----- Select Normal mode "TRUE" ----- Select True mode "WIDE" ----- Select Wide mode "FULL" ----- Select Full mode "CUSTOM" ----- Select Custom mode "DZOOM□UP" ----- Expand image size by Digital Zoom "DZOOM□DN" ----- Compress image size by Digital Zoom "UP" ----- Select screen size with forward switching in possible range (Normal True Wide Full Custom Normal ...) "DN" ----- Select screen size with backward switching in possible range (Normal Custom Full Wide True Normal ...)
	Input is Video signal	"NORMAL" ----- Select Normal mode "WIDE" ----- Select Wide mode "CUSTOM" ----- Select Custom mode "UP" ----- Select screen size with forward switching in possible range (Normal Wide Custom ...) "DN" ----- Select screen size with backward switching in possible range (Custom Wide Normal ...)
	Common in AV/PC	"RST" ----- Reset Screen adjustment
Details	Select screen size. (Valid only when in the normal Power ON status.) When selected Input does not meet the requirement for the specified %1, return "101" [CR] and the command is not executed.	
Response	Acceptable	"000" [CR]
	Unacceptable	"Error Code" [CR]

8.7.2 CF_DZCENT Command

Command	"CF_DZCENT_%1" [CR]	
%1	"CENT" ----- Cancel Digital Zoom (CENT: "CENTER")	
Details	Cancel Digital Zoom mode. (Valid only when in the normal Power ON status and Input for Computer is selected.)	
Response	Acceptable	"000" [CR]
	Unacceptable	"101" [CR] ----- When input is Video

8.7.3 CF_KEYSTONE Command

Command	"CF_KEYSTONE_%1" [CR]	
%1	"UP" ----- Correct Keystone distortion to reduce upper part of image "FUP" ----- Correct Keystone distortion to reduce upper part "DN" ----- Correct Keystone distortion to reduce lower part of image "FDN" ----- Correct Keystone distortion to reduce lower part largely "LEFT" ----- Correct Keystone distortion to reduce left part of image "FLFT" ----- Correct Keystone distortion to reduce left part largely "RIGHT" ----- Correct Keystone distortion to reduce right part of image "FRGT" ----- Correct Keystone distortion to reduce right part largely "RST" ----- Reset Keystone to factory default status	
Details	Change level of Keystone distortion correction (Available only in the normal Power ON status). When reached the limit of the correction level, projector accepts the command but does not execute it. Receiving this command immediately invokes the operation. When trying to set the value beyond available range, error code "201" is returned and the operation is not executed. Example 1: When the correction level of the right part has reached its upper limit and then the command "RIGHT" is received Example 2: When the upper part correction allows only another step, and then the command "FUP" is received.	
Response	Acceptable	"000" [CR]
	Unacceptable	"Error Code" [CR]

8.7.4 CF_KEYSTONEMODE Command

Command	"CF_KYSTNMODE_%1" [CR]	
%1	"STR" ----- Set Keystone store mode to Store "RST" ----- Set Keystone store mode to Reset	
Details	Set Keystone store mode (Available only in the normal Power ON status)	
Response	Acceptable	"000" [CR]
	Unacceptable	"Error Code" [CR]

8.7.5 CF_CEIL Command

Command	"CF_CEIL_%1" [CR]	
%1	"ON" ----- Set Ceiling to ON "OFF" ----- Set Ceiling to OFF	
Details	Set/Cancel Ceiling. (Valid only when in the normal Power ON status.) When Ceiling is set to ON, image is left/right as well as top/bottom reversed. The status set by this command is stored in EEPROM and the setting remains effective after the power is turned to ALL OFF status.	
Response	Acceptable	"000" [CR]
	Unacceptable	"Error Code" [CR]

8.7.6 CF_REAR Command

Command	"CF_REAR_%1" [CR]	
%1	"ON" ----- Set Rear to ON "OFF" ----- Set Rear to OFF	
Details	Set/Cancel Rear. (Valid only when in the normal Power ON status.) When Rear is set to ON, image is left/right reversed. The status set by this command is stored in EEPROM and the setting remains effective after the power is turned to ALL OFF status.	
Response	Acceptable	"000" [CR]
	Unacceptable	"Error Code" [CR]

8.7.7 CF_VSCALE Command

Command	"CF_VSCALE_%1" [CR]	
%1	"035" ----- +35 "031" ----- +31 : "001" ----- +1 "000" ----- ±0 " 01" ----- 1 : " 31" ----- 31 " 32" ----- 32 "UP" ----- Increment setting value of Vscale by 1 "DN" ----- Decrement setting value of Vscale by 1	
Details	Set Vscale (Available only in the normal Power ON status) *When selected screen mode is a setting except Custom, return "101" [CR] and the command is not executed. * When input is no signal, return "101" [CR] and the command is not executed.	
Response	Acceptable	"000" [CR]
	Unacceptable	"Error Code" [CR]

8.7.8 CF_VPOS Command

Command	"CF_VPOS_%1" [CR]	
%1	"015" ----- +15 "014" ----- +14 : "001" ----- +1 "000" ----- ±0 " 01" ----- 1 : " 14" ----- 14 " 15" ----- 15 "UP" ----- Increment setting value of Vposition by 1 "DN" ----- Decrement setting value of Vposition by 1	
Details	Set V Position (Available only in the normal Power ON status) *When selected screen mode is a setting except Custom, return "101" [CR] and the command is not executed. * When input is no signal, return "101" [CR] and the command is not executed.	
Response	Acceptable	"000" [CR]
	Unacceptable	"Error Code" [CR]

8.7.9 CF_HSCALE Command

Command	"CF_HSCALE_%1" [CR]	
%1	"035" ----- +35 "031" ----- +31 : "002" ----- +2 "001" ----- +1 "000" ----- ±0 " 01" ----- 1 " 02" ----- 2 : " 31" ----- 31 " 32" ----- 32 "UP" ----- Increment setting value of Hscale by 1 "DN" ----- Decrement setting value of Hscale by 1	
Details	Set Hscale (Available only in the normal Power ON status) *When selected screen mode is a setting except Custom, return "101" [CR] and the command is not executed. * When input is no signal, return "101" [CR] and the command is not executed.	
Response	Acceptable	"000" [CR]
	Unacceptable	"Error Code" [CR]

8.7.10 CF_HPOS Command

Command	"CF_HPOS_%1" [CR]	
%1	"015" ----- +15 "014" ----- +14 : "002" ----- +2 "001" ----- +1 "000" ----- ±0 " 01" ----- 1 " 02" ----- 2 : " 14" ----- 14 " 15" ----- 15 "UP" ----- Increment setting value of Hposition by 1 "DN" ----- Decrement setting value of Hposition by 1	
Details	Set H Position (Available only in the normal Power ON status) *When selected screen mode is a setting except Custom, return "101" [CR] and the command is not executed. * When input is no signal, return "101" [CR] and the command is not executed.	
Response	Acceptable	"000" [CR]
	Unacceptable	"Error Code" [CR]

8.8 Lamp Command

8.8.1 CF_LAMPMODE Command

Command	"CF_LAMPMODE_%1" [CR]	
%1	"FULL" ----- Set lamp mode to 2-lamp (FULL) "LAMP1" ----- Set lamp1 mode "LAMP2" ----- Set lamp2 mode	
Details	Select Lamp mode. (Valid only when in the normal Power ON status.) The value set by this command is stored in EEPROM and the setting remains effective after the power is turned to ALL OFF status.	
Response	Acceptable	"000" [CR]
	Unacceptable	"Error Code" [CR]

8.8.2 CF_AUTOLAMPCONTRL Command

Command	"CF_AUTOLAMPCONTRL_%1" [CR]	
%1	"NORMAL" ----- Set lamp control mode to NORMAL "ECO1" ----- Set lamp control mode to ECO1 "ECO2" ----- Set lamp control mode to ECO2	
Details	Select Lamp control mode. (Valid only when in the normal Power ON status.) The value set by this command is stored in EEPROM and the setting remains effective after the power is turned to ALL OFF status.	
Response	Acceptable	"000" [CR]
	Unacceptable	"Error Code" [CR]

8.8.3 CF_LAMPLIFECONTRL Command

Command	"CF_LAMPLIFECONTRL_%1" [CR]	
%1	"MODE1" ----- Set Lamp life control mode to Mode1 "MODE2" ----- Set Lamp life control mode to Mode2	
Details	Select Lamp life control. (Valid only when in the normal Power ON status.) The value set by this command is stored in EEPROM and the setting remains effective after the power is turned to ALL OFF status.	
Response	Acceptable	"000" [CR]
	Unacceptable	"Error Code" [CR]

8.8.4 CF_LAMPINTERVAL Command

Command	"CF_LAMPINTERVAL_%1" [CR]	
%1	"AUTO" ----- Set Lamp interval to Auto "0024" ----- Set Lamp interval to 24 hours "0200" ----- Set Lamp interval to 200 hours "0500" ----- Set Lamp interval to 500 hours "1000" ----- Set Lamp interval to 1000 hours "2000" ----- Set Lamp interval to 2000 hours "OFF" ----- Set Lamp interval to OFF	
Details	Select Lamp interval. (Valid only when in the normal Power ON status.) The value set by this command is stored in EEPROM and the setting remains effective after the power is turned to ALL OFF status.	
Response	Acceptable	"000" [CR]
	Unacceptable	"Error Code" [CR]

8.9 Setting Command

8.9.1 CF_LANG Command

Command	"CF_LANG_%1" [CR]	
%1	"ENG" ----- Select ENGLISH "DEU" ----- Select German "FRA" ----- Select French "ITA" ----- Select Italian "ESP" ----- Select Spanish "POR" ----- Select Portuguese "NED" ----- Select Dutch "SVE" ----- Select Swedish "JPN" ----- Select Japanese "CHI" ----- Select Chinese "KOR" ----- Select Korean "RUS" ----- Select Russian	
Details	Select language for OSD. (Valid only when in the normal Power ON status.) The language set by this command is stored in EEPROM and the setting remains effective after the power is turned to ALL OFF status.	
Response	Acceptable	"000" [CR]
	Unacceptable	"Error Code" [CR]

8.9.2 CF_MENUPOSITION Command

Command	"CF_MENUPOSITION_%1" [CR]	
%1	"UP" ----- Move Menu position to upper side. "DN" ----- Move Menu position to lower side. "LEFT" ----- Move Menu position to left side. "RIGHT" ----- Move Menu position to right side.	
Details	Move Menu position. (Valid only when in the normal Power ON status.) This function is worked from the first reception of Command. * When setting beyond the area of movement is carried out, return "101" [CR] and the command is not executed. Ex.1) When movement to right side has already reached limit; and "RIGHT" is received. Ex.2) When "LEFT"/"UP" is received at the default position.	
Response	Acceptable	"000" [CR]
	Unacceptable	"Error Code" [CR]

8.9.3 CF_SIMPLEMENU Command

Command	"CF_SIMPLEMENU_%1" [CR]	
%1	"ON" ----- Set Simple menu to On. "OFF" ----- Set Simple menu to Off.	
Details	Select Simple menu. (Valid only when in the normal Power ON status.) The status set by this command is stored in EEPROM and the setting remains even after the power is turned to ALL OFF status.	
Response	Acceptable	"000" [CR]
	Unacceptable	"Error Code" [CR]

8.9.4 CF_MENUIZE Command

Command	"CF_MENUIZE_%1" [CR]	
%1	"NORMAL" ----- Select Menu size to Normal. "DOUBLE" ----- Select Menu size to Double.	
Details	Select Menu size. (Valid only when in the normal Power ON status.) The status set by this command is stored in EEPROM and the setting remains even after the power is turned to ALL OFF status.	
Response	Acceptable	"000" [CR]
	Unacceptable	"Error Code" [CR]

8.9.5 CF_DISP Command

Command	"CF_DISP_%1" [CR]	
%1	"ON" ----- Set Display to ON "CNTDWN OFF" ----- Set Display to Count down Off "OFF" ----- Set Display to OFF "UP" ----- Switch forward (On → Count down Off → Off → On → ---) "DN" ----- Switch backward (On → Off → Count down Off → On → ---)	
Details	Set/Cancel Display. (Valid only when in the normal Power ON status.) The value set by this command is stored in EEPROM and the setting remains effective after the power is turned to ALL OFF status.	
Response	Acceptable	"000" [CR]
	Unacceptable	"Error Code" [CR]

8.9.6 CF_BACKGND Command

Command	"CF_BACKGND_%1" [CR]	
%1	"BLUE" ----- Select Blue Back "USER" ----- Select User "BLACK" ----- Select Black Back "UP" ----- Switch forward (Blue Back→User→Black Back→Blue Back) "DN" ----- Switch backward (Blue Back→Black Back→User→Blue Back)	
Details	Set Screen status for no signal.(Available only in the normal Power ON status) The status set by this command is stored in EEPROM and the setting remains even after the power is turned to ALL OFF status. *When %1="USER" is received, error code "101" is returned, in the case of Capture non-practice.	
Response	Acceptable	"000" [CR]
	Unacceptable	"Error Code" [CR]

8.9.7 CF_PIP Command

Command	"CF_PIP_%1" [CR]	
%1	"OFF" ----- Select Off "USER1" ----- Select User1 "USER2" ----- Select User2 "USER3" ----- Select User3 "USER4" ----- Select User4 "USER5" ----- Select User5	
Details	Set "Picture in Picture" status.(Available only in the normal Power ON status) The status set by this command is stored in EEPROM and the setting remains even after the power is turned to ALL OFF status.	
Response	Acceptable	"000" [CR]
	Unacceptable	"Error Code" [CR]

8.9.8 CF_PIPMAININP Command

Command	"CF_PIPMAININP_%1_%2" [CR]	
%1	"1" ----- Select Input 1 "2" ----- Select Input 2 "3" ----- Select Input 3 "4" ----- Select Input 4	
%2	"DIGITAL" ----- Select DVI Input "ANALOG" ----- Select Analog Input "VIDEO" ----- Select Composite Video Input "S-VIDEO" ----- Select S-Video input "YPBPR" ----- Select Y/Pb/Pr Input "YCBCR" ----- Select Y/Cb/Cr Input "SDI1" ----- Select SDI 1 Input "SDI2" ----- Select SDI 2 Input "SCART" ----- Select SCART Input "HDCP" ----- Select HDCP Input "HDMI" ----- Select HDMI Input	
Details	Select input and source of Main picture of "Picture in Picture". (Valid only when in the normal Power ON status.) * In the case of a specific status, return Error Code "101" [CR] and the command is not executed. -When selected Source does not meet the requirement for Input -When transmitted command of the input without inserting Board in Input3 or Input4 -When selected Input / Source which was impossible of choice by limit of Picture in Picture	
Response	Acceptable	"000" [CR]
	Unacceptable	"Error Code" [CR]

8.9.9 CF_PIPSUBINPU Command

Command	"CF_PIPSUBINPU_%1_%2" [CR]	
%1	"1" ----- Select Input 1 "2" ----- Select Input 2 "3" ----- Select Input 3 "4" ----- Select Input 4	
%2	"DIGITAL" ----- Select DVI Input "ANALOG" ----- Select Analog Input "VIDEO" ----- Select Composite Video Input "S-VIDEO" ----- Select S-Video input "YPBPR" ----- Select Y/Pb/Pr Input "YCBCR" ----- Select Y/Cb/Cr Input "SDI1" ----- Select SDI 1 Input "SDI2" ----- Select SDI 2 Input "SCART" ----- Select SCART Input "HDCP" ----- Select HDCP Input "HDMI" ----- Select HDMI Input	
Details	Select input and source of Sub picture of "Picture in Picture". (Valid only when in the normal Power ON status.) * In the case of a specific status, return "101" [CR] and the command is not executed. -When selected Source does not meet the requirement for Input -When transmitted command of the input without inserting Board in Input3 or Input4 -When selected Input / Source which was impossible of choice by limit of "Picture in Picture"	
Response	Acceptable	"000" [CR]
	Unacceptable	"Error Code" [CR]

8.9.10 CF_PIPSIZE Command

Command	"CF_PIPSIZE_%1_%2" [CR]	
%1	"1" ----- Set main picture size to 10% "2" ----- Set main picture size to 20% "3" ----- Set main picture size to 30% "4" ----- Set main picture size to 40% "5" ----- Set main picture size to 50% "6" ----- Set main picture size to 60% "7" ----- Set main picture size to 70% "8" ----- Set main picture size to 80% "9" ----- Set main picture size to 90% "10" ----- Set main picture size to 100%	
%2	"1" ----- Set sub picture size to 10% "2" ----- Set sub picture size to 20% "3" ----- Set sub picture size to 30% "4" ----- Set sub picture size to 40% "5" ----- Set sub picture size to 50%	
Details	Set display size of "Picture in Picture". (Valid only when in the normal Power ON status.) *When "Picture in Picture" is set to Off, return "101" [CR]	
Response	Acceptable	"000" [CR]
	Unacceptable	"Error Code" [CR]

8.9.11 CF_PIPPOSITION Command

Command	"CF_PIPPOSITION_%1" [CR]	
%1	"POS1" ----- Move main picture position to up "POS2" ----- Move main picture position to down "POS3" ----- Move main picture position to left "POS4" ----- Move main picture position to right "POS5" ----- Move sub picture position to up "POS6" ----- Move sub picture position to down "POS7" ----- Move sub picture position to left "POS8" ----- Move sub picture position to right	
Details	Set position of "Picture in Picture". (Valid only when in the normal Power ON status.) This function is worked from the first reception of Command. * When setting beyond the area of movement is carried out, return Error Code "101" [CR] and the command is not executed. Ex.1) When movement to right side has already reached limit; and "RIGHT" is received. *When "Picture in Picture" is set to Off, return "101" [CR]	
Response	Acceptable	"000" [CR]
	Unacceptable	"Error Code" [CR]

8.9.12 CF_PIPFRAMELOCK Command

Command	"CF_PIPFRAMELOCK_%1" [CR]	
%1	"MAIN" ----- Set to main picture "SUB" ----- Set to sub picture	
Details	Set Frame lock of "Picture in Picture". (Valid only when in the normal Power ON status.)	
Response	Acceptable	"000" [CR]
	Unacceptable	"Error Code" [CR]

8.9.13 CF_PIPSTORE Command

Command	"CF_PIPSTORE_%1" [CR]	
%1	"USER1"---- Store current setting status to User 1 "USER2"---- Store current setting status to User 2 "USER3"---- Store current setting status to User 3 "USER4"---- Store current setting status to User 4 "USER5"---- Store current setting status to User 5	
Details	Store setting status of "Picture in Picture". (Valid only when in the normal Power ON status.) This command operates the same way as storing to User1-5 in "Picture in Picture" Menu. The status set by this command is stored in EEPROM and the setting remains even after the power is turned to ALL OFF status.	
Response	Acceptable	"000" [CR]
	Unacceptable	"Error Code" [CR]

8.9.14 CF_PIPMODEFREE Command

Command	"CF_PIPMODEFREE_%1" [CR]	
%1	"USER1" ----- Set User1 to Free status "USER 2" ----- Set User2 to Free status "USER 3" ----- Set User3 to Free status "USER 4" ----- Set User4 to Free status "USER 5" ----- Set User5 to Free status	
Details	Delete the data registered in Custom User1–5 and returns it to Free status. This command operates the same way as resetting to User1-5 in "Picture in Picture" Menu. (Available only in the normal Power ON status) *When there is only one user mode of stored state, return "101" [CR]	
Response	Acceptable	"000" [CR]
	Unacceptable	"Error Code" [CR]

8.9.15 CF_PIPRST Command

Command	"CF_PIPRST_%1" [CR]	
%1	"RST" ----- Reset current setting status	
Details	Reset current setting status of "Picture in Picture". (Available only in the normal Power ON status)	
Response	Acceptable	"000" [CR]
	Unacceptable	"Error Code" [CR]

8.9.16 CF_EDGEBLENDING Command

Command	"CF_EDGEBLENDING_%1" [CR]	
%1	"ON" ----- Set Edge blending to On "OFF" ----- Set Edge blending to Off	
Details	Set Edge blending.(Available only in the normal Power ON status) The status set by this command is stored in EEPROM and setting remains effective even after the power is turned to ALL OFF status.	
Response	Acceptable	"000" [CR]
	Unacceptable	"Error Code" [CR]

8.9.17 CF_BLEND Command

Command	"CF_BLEND_%1_%2" [CR]	
%1	"LEFT" ----- Left side "RIGHT" ----- Right side "TOP" ----- Upper side "BOTTOM" ----- Lower side	
%2	"000"-"700"----- Directly specify value of direction of %1 *Value of upper limit changes by choice of %1 Left ----- 000~700 Right ----- 000~700 Top ----- 000~525 Bottom ----- 000~525	
Details	Set value of direction specified by Edge blending %1. (Available only in the normal Power ON status) The status set by this command is stored in EEPROM and setting remains effective even after the power is turned to ALL OFF status.	
Response	Acceptable	"000" [CR]
	Unacceptable	"Error Code" [CR]

8.9.18 CF_BLENDBLK Command

Command	"CF_BLENDBLK_%1_%2" [CR]	
%1	"R" ----- Red "G" ----- Green "B" ----- Blue	
%2	"-127" ~ "0127"----- Directly specify value of color of %1	
Details	Set value of color specified by Edge blending %1. (Available only in the normal Power ON status) The status set by this command is stored in EEPROM and setting remains effective even after the power is turned to ALL OFF status.	
Response	Acceptable	"000" [CR]
	Unacceptable	"Error Code" [CR]

8.9.19 CF_BLENDBLKALL Command

Command	"CF_BLENDBLKALL_%1" [CR]	
%1	"UP" ----- Increment value of Black level(R/G/B) by 1 "DN" ----- Decrement value of Black level(R/G/B) by 1	
Details	Set value of all of Black level of Edge blending. (Available only in the normal Power ON status) The status set by this command is stored in EEPROM and setting remains effective even after the power is turned to ALL OFF status.	
Response	Acceptable	"000" [CR]
	Unacceptable	"Error Code" [CR]

8.9.20 CF_BLENDTESTPAT Command

Command	"CF_BLENDTESTPAT_%1" [CR]	
%1	"ON" ----- Set to On "OFF" ----- Set to Off	
Details	Set Test pattern of Edge blending.(Available only in the normal Power ON status) The status set by this command is stored in EEPROM and setting remains effective even after the power is turned to ALL OFF status.	
Response	Acceptable	"000" [CR]
	Unacceptable	"Error Code" [CR]

8.9.21 CF_BLENDRST Command

Command	"CF_BLENDRST_%1" [CR]	
%1	"RST" ----- Reset current setting status	
Details	Reset current setting status of Edge blending. (Available only in the normal Power ON status)	
Response	Acceptable	"000" [CR]
	Unacceptable	"Error Code" [CR]

8.9.22 CF_COLORMATCHING Command

Command	"CF_COLORMATCHING_%1" [CR]	
%1	"ON" ----- Set to On "OFF" ----- Set to Off	
Details	Set status of Color matching.(Available only in the normal Power ON status) The status set by this command is stored in EEPROM and setting remains effective even after the power is turned to ALL OFF status.	
Response	Acceptable	"000" [CR]
	Unacceptable	"Error Code" [CR]

8.9.23 CF_CMMSXY Command

Command	"CF_CMMSXY_%1_%2_%3" [CR]	
%1	"RED" ----- Set value of Red "GREEN" ----- Set value of Green "BLUE" ----- Set value of Blue "WHITE" ----- Set value of White "HALFWHITE" ----- Set value of Half white	
%2	"0000" – "1000" ----- Directly specify "x" value of color of %1	
%3	"0000" – "1000" ----- Directly specify "y" value of color of %1	
Details	Set "x","y" value of Measured of Color matching. (Available only in the normal Power ON status) *The selectable colors are different by using color wheel. For brightness: Red/Green/Blue/Half white/White For color reproduction: Red/Green/Blue/White *When transmit the command of the color that is impossible of choice, return "101" [CR].	
Response	Acceptable	"000" [CR]
	Unacceptable	"Error Code" [CR]

8.9.24 CF_CMMSL Command

Command	"CF_CMMSL_%1_%2" [CR]	
%1	"RED" ----- Set value of Red "GREEN" ----- Set value of Green "BLUE" ----- Set value of Blue "WHITE" ----- Set value of White "HALFWHITE" ----- Set value of Half white	
%2	"0000" – "1000" ----- Directly specify "L" value of color of %1	
Details	Set "L" value of Measured of Color matching. (Available only in the normal Power ON status) *The selectable colors are different by using color wheel. For brightness: Red/Green/Blue/Half white/White For color reproduction: Red/Green/Blue/White *When transmit the command of the color that is impossible of choice, return "101" [CR].	
Response	Acceptable	"000" [CR]
	Unacceptable	"Error Code" [CR]

8.9.25 CF_CMTGXY Command

Command	"CF_CMTGXY_%1_%2_%3" [CR]	
%1	"RED" ----- Set value of Red "GREEN" ----- Set value of Green "BLUE" ----- Set value of Blue "WHITE" ----- Set value of White "CYAN" ----- Set value of Cyan "MAGENTA" ----- Set value of Magenta "YELLOW" ----- Set value of Yellow	
%2	"0000" – "1000" ----- Directly specify "x" value of color of %1	
%3	"0000" – "1000" ----- Directly specify "y" value of color of %1	
Details	Set "x","y" value of Target of Color matching. (Available only in the normal Power ON status)	
Response	Acceptable	"000" [CR]
	Unacceptable	"Error Code" [CR]

8.9.26 CF_CMTGG Command

Command	"CF_CMTGG_%1_%2" [CR]	
%1	"RED" ----- Set value of Red "GREEN" ----- Set value of Green "BLUE" ----- Set value of Blue "WHITE" ----- Set value of White "CYAN" ----- Set value of Cyan "MAGENTA" ----- Set value of Magenta "YELLOW" ----- Set value of Yellow	
%2	"0000" – "1000" ----- Directly specify "g" value of color of %1	
Details	Set "g" value of Target of Color matching. (Available only in the normal Power ON status)	
Response	Acceptable	"000" [CR]
	Unacceptable	"Error Code" [CR]

8.9.27 CF_CMAUTOTESTPAT Command

Command	"CF_CMAUTOTESTPAT_%1" [CR]	
%1	"ON" ----- Set to On "OFF" ----- Set to Off	
Details	Set Auto test pattern of Color matching. (Available only in the normal Power ON status)	
Response	Acceptable	"000" [CR]
	Unacceptable	"Error Code" [CR]

8.9.28 CF_CMRST Command

Command	"CF_CMRST_%1" [CR]	
%1	"CMRST" ----- Reset setting of Color matching "ADCRST" ----- Reset setting of Advanced color matching	
Details	Reset setting of Color matching.(Available only in the normal Power ON status)	
Response	Acceptable	"000" [CR]
	Unacceptable	"Error Code" [CR]

8.9.29 CF_CMSTORE Command

Command	"CF_CMSTORE_%1" [CR]	
%1	"CMSTR" ----- Store setting of Color matching "ADCSTR" ----- Store setting of Advanced color matching	
Details	Store setting of Color matching.(Available only in the normal Power ON status)	
Response	Acceptable	"000" [CR]
	Unacceptable	"Error Code" [CR]

8.9.30 CF_CMMSTESTPAT Command

Command	"CF_CMMSTESTPAT_%1" [CR]	
%1	"RED" ----- Display Red "GREEN" ----- Display Green "BLUE" ----- Display Blue "WHITE" ----- Display White "HALFWHITE" ----- Display Half white "OFF" ----- Do not show test pattern display	
Details	Display Test pattern of Measured of Color matching. (Available only in the normal Power ON status) *The selectable colors are different by using Color wheel. For brightness: Red/Green/Blue/Half white/White For color reproduction: Red/Green/Blue/White *When transmit the command of the color that is impossible of choice, return "101" [CR].	
Response	Acceptable	"000" [CR]
	Unacceptable	"Error Code" [CR]

8.9.31 CF_CMTGTESTPAT Command

Command	"CF_CMTGTESTPAT_%1" [CR]	
%1	"RED" ----- Display Red "GREEN" ----- Display Green "BLUE" ----- Display Blue "WHITE" ----- Display White "CYAN" ----- Display Cyan "MAGENTA" ----- Display Magenta "YELLOW" ----- Display Yellow "OFF" ----- Do not show test pattern display	
Details	Display Test pattern of Target of Color matching. (Available only in the normal Power ON status)	
Response	Acceptable	"000" [CR]
	Unacceptable	"Error Code" [CR]

8.9.32 CF_CMFDEFAULT Command

Command	"CF_CMFDEFAULT_%1" [CR]	
%1	"RST" ----- Reset current data of Color matching	
Details	Return Color matching settings to Factory Default status (Available only in the normal Power ON status)	
Response	Acceptable	"000" [CR]
	Unacceptable	"Error Code" [CR]

8.9.33 CF_DYNAMICBLACK Command

Command	"CF_DYNAMICBLACK_%1" [CR]	
%1	"LOW" ----- Set to Low "HIGH" ----- Set to High "OFF" ----- Set to Off	
Details	Set status of DynamicBlack.(Available only in the normal Power ON status) The status set by this command is stored in EEPROM and the setting remains effective after the power is turned to ALL OFF status.	
Response	Acceptable	"000" [CR]
	Unacceptable	"Error Code" [CR]

8.9.34 CF_HDMISETUP Command

Command	"CF_HDMISETUP_%1" [CR]	
%1	"NORMAL" ----- Set to Normal "ENHANCED" ----- Set to Enhanced	
Details	Set status of HDMI setup.(Available only in the normal Power ON status) The status set by this command is stored in EEPROM and the setting remains effective after the power is turned to ALL OFF status.	
Response	Acceptable	"000" [CR]
	Unacceptable	"Error Code" [CR]

8.9.35 CF_LOGO Command

Command	"CF_LOGO_%1_%2" [CR]	
%1	"0000 – 9999" ----- Directly set Logo PIN code	
%2	"OFF" ----- Cancel Logo display "DFLT" ----- Select Logo of Factory Default "USER" ----- Select User "UP" ----- Select functions to choose forward (OFF → DFLT → USER → OFF → --) "DN" ----- Select functions to choose backward (OFF → USER → DFLT → OFF → --)	
Details	Set Logo mode.(Available only in the normal Power ON status) The status set by this command is stored in EEPROM and setting remains effective even after the power is turned to ALL OFF status. Set Logo PIN code in %1. *When Logo Lock is enabled: PIN code is matched ----- Command is valid (Acceptable) PIN code is mismatched----- Command is invalid (Error code "102") PIN code is beyond %1 available range ----- Command is invalid (Error code"?)") *When Logo Lock is disabled: PIN code is within %1 available range ----- Command is valid (Acceptable) PIN code is out of %1 available range ----- Command is invalid (Error code "?") Note: When Logo Lock is enabled, matching Logo PIN code switches Logo but Logo Lock is not cancelled (Lock status is kept). *When %2="USER" is received, error code "101" is returned, in the case of Capture non-practice.	
Response	Acceptable	"000" [CR]
	Unacceptable	"Error Code" [CR]

8.9.36 CF_FANSPEED Command

Command	"CF_FANSPEED_%1" [CR]	
%1	"MAX" ----- Select Maximum speed of Fan Control "NOR" ----- Select Normal speed of Fan Control	
Details	Switch Fan Control Speed. (Valid only when in the normal Power ON status.) The status set by this command is stored in EEPROM and the setting remains effective after the power is turned to ALL OFF status.	
Response	Acceptable	"000" [CR]
	Unacceptable	"Error Code" [CR]

8.9.37 CF_RCODE Command

Command	"CF_RCODE_%1" [CR]	
%1	"001" ----- Select Code 1 "002" ----- Select Code 2 "003" ----- Select Code 3 "004" ----- Select Code 4 "005" ----- Select Code 5 "006" ----- Select Code 6 "007" ----- Select Code 7 "008" ----- Select Code 8 "UP" ----- Switch forward (Code1→Code2→Code3 - - -→Code8→Code1) "DN" ----- Switch backward (Code8→Code7→Code6 - - -→Code1→Code8)	
Details	Select Remote Control Code (Valid only when in the normal Power ON status) The status set by this command is stored in EEPROM and the setting remains effective after the power is turned to ALL OFF status.	

Response	Acceptable	"000" [CR]
	Unacceptable	"Error Code" [CR]

8.9.38 CF_RSENS Command

Command	"CF_RSENS_%1" [CR]	
%1	"ALL" ----- Select all receiver of projector "FRONTTOP" ----- Select both front and top receiver of projector "BACKTOP" ----- Select both back and top receiver of projector "FRONTBACK" ----- Select both front and back receiver of projector "FRONT" ----- Select only front receiver of projector "TOP" ----- Select only top receiver of projector "BACK" ----- Select only back receiver of projector "UP" ----- Switch forward (ALL → FRONTTOP→BACKTOP→ FRONTBACK→ FRONT →TOP → BACK→ALL) "DN" ----- Switch backward (BACK →TOP→FRONT→FRONTBACK →BACKTOP →FRONTTOP→ ALL→BACK)	
Details	Select location of infrared remote receiver of remote control (Available only in the normal Power ON status) The status set by this command is stored in EEPROM and setting remains effective even after the power is turned to ALL OFF status.	
Response	Acceptable	"000" [CR]
	Unacceptable	"Error Code" [CR]

8.9.39 CF_P-MANE Command

Command	"CF_P-MANE_%1" [CR]	
%1	"OFF" ----- Set Power Management to Off "READY" ----- Set Power Management to Ready "SHUTDOWN" ----- Set Power Management to Shut Down mode "UP" ----- Switch forward (Off→Ready→Shut down→Off) "DN" ----- Switch backward (Off→Shut down→Ready→Off)	
Details	Set/Cancel Power Management. (Valid only when in the normal Power ON status.) The status set by this command is stored in EEPROM and the setting remains effective after the power is turned to ALL OFF status.	
Response	Acceptable	"000" [CR]
	Unacceptable	"Error Code" [CR]

8.9.40 CF_P-MANETIME Command

Command	"CF_P-MANETIME_%1" [CR]	
%1	"01" - "30" ----- Directly specify setting time by the minute "UP" ----- Increment value by 1 (Switched in 01→02→ --- → 30 → 01 order) "DN" ----- Decrement value by 1 (Switched in 30→29→ --- → 01 → 30 order)	
Details	Set time of Power Management time (Available only in the normal Power ON status). The status set by this command is stored in EEPROM and setting remains effective even after the power is turned to ALL OFF status.	
Response	Acceptable	"000" [CR]
	Unacceptable	"Error Code" [CR]

8.9.41 CF_ON-STA Command

Command	"CF_ON-STA_%1" [CR]	
%1	"ON" ----- Set Power On Start to ON. "OFF" ----- Set Power On Start to OFF. "UP" ----- Toggle between ON and OFF.(On→Off→On → - - -) "DN" ----- Toggle between ON and OFF.(On→Off→On → - - -) **"UP" and "DN" are exactly same operation.	
Details	Set/Cancel Power ON Start (Only valid when it is in the normal Power ON status) The status set by this command is stored in EEPROM and the setting remains effective after the power is turned to ALL OFF status.	
Response	Acceptable	"000" [CR]
	Unacceptable	"Error Code" [CR]

8.9.42 CF_PJPINCODE Command

Command	"CF_PJPINCODE_%1" [CR]	
%1	"0000 – 9999" ----- Directly specify PJ PIN code	
Details	Enter PIN code to cancel PIN code lock (Available only in the normal Power ON status) PIN code can not be changed. (Only PIN code lock is canceled.) *When PIN code Lock is enabled: PIN code is matched ----- Command is valid (Acceptable) PIN code is mismatched ----- Command is invalid (Error code "102") PIN code is beyond %1 available range ----- Command is invalid (Error code "?") *When PIN code lock is canceled: PIN code is within %1 range ----- Command is valid (Acceptable) PIN code is out of %1 range ----- Command is invalid (Error code is 102) This command is only valid when "PJ PIN code" dialog is displayed to enter PIN code after Power is ON and Countdown is completed. When PIN code lock is set to "On1", it needs to send this command every time the projector is turned on.	
Response	Acceptable	"000" [CR]
	Unacceptable	"Error Code" [CR]

8.9.43 CF_FILH Command

Command	"CF_FILH_%1" [CR]	
%1	"RST" ----- Reset Filter used time	
Details	Reset used time for filter of projector	
Response	Acceptable	"000" [CR]
	Unacceptable	"Error Code" [CR]

8.9.44 CF_FILTERTIMER Command

Command	"CF_FILTERTIMER_%1" [CR]	
%1	"1000" ----- Set 1000 hours "2000" ----- Set 2000 hours "3000" ----- Set 3000 hours "OFF" ----- Set Off(Do not warning display)	
Details	Set time to display Filter cleaning / replacement warning on screen	
Response	Acceptable	"000" [CR]
	Unacceptable	"Error Code" [CR]

8.9.45 CF_FILCTL Command

Command	"CF_FILCTL_%1" [CR]	
%1	"ROLL" ----- Execute operation of scroll of filter	
Details	Execute operation of scroll of filter	
Response	Acceptable	Acceptable
	Unacceptable	Unacceptable

8.9.46 CF_FILSCRL Command

Command	"CF_FILSCRL_%1" [CR]	
%1	"RST" ----- Reset Filter scroll counter	
Details	Reset Filter scroll counter	
Response	Acceptable	Acceptable
	Unacceptable	Unacceptable

8.9.47 CF_TESTPAT Command

Command	"CF_TESTPAT_%1" [CR]	
%1	"COLOR" ----- Display Color bar "GRAD1" ----- Display 16step(white→black) "GRAD2" ----- Display 16step(white←black) "GRAD3" ----- Display 16step(white↓black) "GRAD4" ----- Display 16step(white↑black) "WHITE" ----- Display all white "BLACK" ----- Display all black "CROSS" ----- Display Cross "OFF" ----- Do not show test pattern display "UP" ----- Switch forward "DN" ----- Switch backward	
Details	Execute test pattern display.(Available only in the normal Power ON status)	
Response	Acceptable	"000" [CR]
	Unacceptable	"Error Code" [CR]

8.9.48 CF_FDEFAULT Command

Command	"CF_FDEFAULT_%1" [CR]	
%1	"RST"	
Details	Return the settings to Factory Default status (Valid only when in the normal Power ON status)	
Response	Acceptable	"000" [CR]
	Unacceptable	"Error Code" [CR]

8.9.49 CF_KEYDIS Command

Command	"CF_KEYDIS_%1" [CR]	
%1	"NONE" ----- RC & KEY are valid "RC" ----- RC is invalid "KEY" ----- KEY is invalid	
Details	Set the limitation of RC/KEY use (Valid only when in the normal Power ON status)	
Response	Acceptable	"000" [CR]
	Unacceptable	"Error Code" [CR]

8.9.50 CF_SHUTRCPROT Command

Command	"CF_SHUTRCPROT_%1" [CR]	
%1	"ON" ----- Disable RC key from controlling Shutter (Protection On) "OFF" ----- Enable RC key to control Shutter (Protection Off)	
Details	Set valid / invalid of RC use on Shutter control function (Valid only when in the normal Power ON status)	
Response	Acceptable	"000" [CR]
	Unacceptable	"Error Code" [CR]

8.9.51 CF_SHUTKEYPROT Command

Command	"CF_SHUTKEYPROT_%1" [CR]	
%1	"ON" ----- Disable key on the top panel from controlling Shutter (Protection On) "OFF" ----- Enable key on the top panel to control Shutter (Protection Off)	
Details	Set valid / invalid use of key on the top panel on Shutter control function. (Valid only when in the normal Power ON status)	
Response	Acceptable	"000" [CR]
	Unacceptable	"Error Code" [CR]

8.9.52 CF_SHUTH Command

Command	"CF_SHUTH_%1" [CR]	
%1	"005"- "180"-----Specify setting time directly "UP" ----- Add 1 minute "DN" -----Decrease 1 minute	
Details	Set time of operating shutter management function. (Valid only when in the normal Power ON status) The status set by this command is stored in EEPROM and setting remains effective even after the power is turned to ALL OFF status.	
Response	Acceptable	"000" [CR]
	Unacceptable	"Error Code" [CR]

8.10 Other Command

8.10.1 CF_KEYEMU Command

Command	"CF_KEYEMU_%1" [CR]	
%1	<p>"RIGHT" ----- Move Pointer rightward in On-Screen Display Menu "LEFT" ----- Move Pointer leftward in On-Screen Display Menu "UP" ----- Move Pointer to upward On-Screen Display Menu "DN" ----- Move Pointer to downward in On-Screen Display Menu "SELECT" ----- The same operation as "SELECT" button of RC "AUTOPC" ----- Execute Auto PC Adj. operation</p>	
Details	<p>The same operation as Control Key. Auto PC Adj. operation is not stopped before getting back a return value during this Auto PC Adj. operation even if this command is received again.</p> <p>*When transmit command of CF_KEYEMU parameter - When User menu is displayed: function is carried out with having displayed User menu. - When User menu isn't displayed: error code "101" is returned, function is non-practice.</p> <p>* "101" is not returned even if a command of CF_KEYEMU is transmitted when cursor moves to the item which cannot toggle at an edge of the main menu.</p> <p>example: Display main menu, and move to second menu of Image adj. Move a cursor to "Quit" position, and transmit a command of KEYEMU_DN. Then a cursor doesn't toggle and "000" is returned.</p> <p>*When transmit command of CF_KEYEMU AUTOPC - When practice of Auto pc adj is possible: Function is practice, "000" is returned. - When practice of Auto pc adj is impossible: display exclamation mark, "000" is returned.</p>	
Response	Acceptable	"000" [CR]
	Unacceptable	"Error Code" [CR]

8.10.2 CF_MENU Command

Command	"CF_MENU_%1" [CR]	
%1	<p>"ON" ----- Display On-Screen Display Menu "OFF" ----- Hide On-Screen Display Menu</p>	
Details	Set On-Screen Display mode. (Available only in the normal Power ON status)	
Response	Acceptable	"000" [CR]
	Unacceptable	"Error Code" [CR]

8.10.3 CF_POWER Command

Command	"CF_POWER_%1" [CR]	
%1	<p>"ON" ----- Power ON "OFF" ----- Power OFF * Issuing another command during countdown process forced countdown operation to be terminated. * Error Code is returned in some projector statuses, which indicates the command is impossible to be executed. (See [8.3] for details) * Returning the response "000" [CR] (acceptable) does not always mean that the status has already changed to Power ON. Example: When the temperature approaches abnormal status after returning "000" [CR] to the command CF_POWER ON. Therefore, to get the projector status requires using Status Read command.</p>	
Details	Set Power to ON/OFF	
Response	Acceptable	"000" [CR]
	Unacceptable	"Error Code" [CR]

8.10.4 CF_FREEZE Command

Command	"CF_FREEZE_%1" [CR]	
%1	<p>"ON" ----- Set Freeze to ON. "OFF" ----- Set Freeze to OFF. "UP" ----- Switch forward (On→Off→On→---) "DN" ----- Switch backward (On→Off→On→---) * The same operation for "UP" and "DN" as this model has only "ON" / "OFF".</p>	
Details	Set / Cancel Freeze function. (Available only in the normal Power ON status) Receiving FREEZE_ON command when the projector is Freeze enabled, Freeze status is kept.	
Response	Acceptable	"000" [CR]
	Unacceptable	"Error Code" [CR]

8.10.5 CF_VMUTE Command

Command	"CF_VMUTE_%1" [CR]	
%1	<p>"ON" ----- Set Video Mute to ON (Shutter Close). "OFF" ----- Set Video Mute to OFF (Shutter Open).</p>	
Details	ON / OFF Video Mute function. (Available only in the normal Power ON status)	
Response	Acceptable	"000" [CR]
	Unacceptable	"Error Code" [CR]

9 . Status Read Command

9.1 Format

- 1) PC issues a command in the format below:

“CR_Command” [CR]

Command: String

- 2) When the projector receives the applicable command, it returns the required information as a data string.

“000_”%1 [CR]

%1: required Information (a data string. Refer to [Basic Status Read Command Table])

- 3) When the received data cannot be decoded, the projector returns “?” [CR]

9.2 Transfer Example

Getting total dots of the projector by Expand Serial Commands

PC → PJ: “CR_TDOTS” [CR]

PC ← PJ: “000_1344” [CR]

9.3 Operation condition

Basically it should be always operated.

9.4 Image Status Read Commands

9.4.1 CR_CONT Command

Command	"CR_CONT" [CR]	
Details	Get user controlled value of Contrast	
Response	Acceptable	"000_%1" [CR]
	%1	"000" – "063"
	Unacceptable	"?" [CR]

9.4.2 CR_BRIGHT Command

Command	"CR_BRIGHT" [CR]	
Details	Get user controlled value of Brightness	
Response	Acceptable	"000_%1" [CR]
	%1	"000" – "063"
	Unacceptable	"?" [CR]

9.4.3 CR_COLOR Command

Command	"CR_COLOR" [CR]	
Details	Get user controlled value of Color	
Response	Acceptable	"000_%1" [CR]
	%1	"000" – "063"
	Unacceptable	"Error Code" [CR] -----When command is invalid in the given condition (such as being selected input) "?" [CR] ----- When unknown command is received

9.4.4 CR_TINT Command

Command	"CR_TINT" CR]	
Details	Get user controlled value of Tint	
Response	Acceptable	"000_%1" [CR]
	%1	"000" – "063"
	Unacceptable	"Error Code" [CR] -----When command is invalid in the given condition (such as being selected input) "?" [CR] ----- When unknown command is received

9.4.5 CR_APCTRL Command

Command	"CR_APCTRL" [CR]	
Details	Get setting status of Auto Picture Control	
Response	Acceptable	"000_%1" [CR]
	%1	"L1" ----- Operate Auto Picture Control with Level1 "L2" ----- Operate Auto Picture Control with Level2 "OFF" ----- Set Auto Picture Control OFF
	Unacceptable	"?" [CR]

9.4.6 CR_COLTEMP Command

Command	"CR_COLTEMP" [CR]	
Details	Get Color Temperature setting status	
Response	Acceptable	"000_%1" [CR]
	%1	"000" ~ "003" "CLEAR" ---- Clear base "BLUE" ----- Blue base "BLANK" ---- OSD Menu is blank (Neither of Xlow / Low / Mid / High)
	Unacceptable	"?" [CR]

9.4.7 CR_WBAL-R Command

Command	"CR_WBAL-R" [CR]	
Details	Get user controlled Red value of White Balance	
Response	Acceptable	"000_%1" [CR]
	%1	"000" – "063"
	Unacceptable	"?" [CR]

9.4.8 CR_WBAL-G Command

Command	"CR_WBAL-G" [CR]	
Details	Get user controlled Green value of White Balance	
Response	Acceptable	"000_%1" [CR]
	%1	"000" – "063"
	Unacceptable	"?" [CR]

9.4.9 CR_WBAL-B Command

Command	"CR_WBAL-B" [CR]	
Details	Get user controlled Blue value of White Balance	
Response	Acceptable	"000_%1" [CR]
	%1	"000" – "063"
	Unacceptable	"?" [CR]

9.4.10 CR_OFFSET-R Command

Command	"CR_OFFSET-R" [CR]	
Details	Get user controlled Red value of Offset	
Response	Acceptable	"000_%1" [CR]
	%1	"000" – "063"
	Unacceptable	"?" [CR]

9.4.11 CR_OFFSET-G Command

Command	"CR_OFFSET-G" [CR]	
Details	Get user controlled Green value of Offset	
Response	Acceptable	"000_%1" [CR]
	%1	"000" – "063"

	Unacceptable	"?" [CR]
--	--------------	----------

9.4.12 CR_OFFSET-B Command

Command	"CR_OFFSET-B" [CR]	
Details	Get user controlled Blue value of Offset	
Response	Acceptable	"000_%1" [CR]
	%1	"000" – "063"
	Unacceptable	"?" [CR]

9.4.13 CR_SHARP Command

Command	"CR_SHARP" [CR]	
Details	Get user controlled value of Sharpness	
Response	Acceptable	"000_%1" [CR]
	%1	"000" – "031"
	Unacceptable	"?" [CR]

9.4.14 CR_GAMMA Command

Command	"CR_GAMMA" [CR]	
Details	Get user controlled value of Gamma	
Response	Acceptable	"000_%1" [CR]
	%1	"000" – "015"
	Unacceptable	"?" [CR]

9.4.15 CR_NZRED Command

Command	"CR_NZRED" [CR]	
Details	Get Noise Reduction setting status	
Response	Acceptable	"000_%1" [CR]
	%1	"ON" ----- Noise Reduction is ON "OFF" ----- Noise Reduction is OFF
	Unacceptable	"Error Code" [CR] -----When command is invalid in the given condition (such as being selected input) "?" [CR] ----- When unknown command is received

9.4.16 CR_PROGV Command

Command	"CR_PROGV" [CR]	
Details	Get Progressive scan setting status	
Response	Acceptable	"000_%1" [CR]
	%1	"ON" ----- Set Progressive scan On "FILM" ----- Select FILM mode "OFF" ----- Set Progressive scan Off
	Unacceptable	"Error Code" [CR] -----When command is invalid in the given condition (such as being selected input) "?" [CR] ----- When unknown command is received

9.4.17 CR_BCOLOR Command

Command	"CR_PROGV" [CR]	
Details	Get BrilliantColor setting status	
Response	Acceptable	"000_%1" [CR]
	%1	"ON" ----- Set BrilliantColor to On "OFF" ----- Set BrilliantColor to Off
	Unacceptable	"Error Code" [CR] -----When command is invalid in the given condition (such as being selected input) "?" [CR] ----- When unknown command is received

9.4.18 CR_IMAGE Command

Command	"CR_IMAGE" [CR]	
Details	Get image setting status. The Required data "CUSTOM1" – "CUSTOM10" corresponds to "Image1" – "Image10" displayed when selecting Image on OSD Menu.	
Response	Acceptable	"000_%1" [CR]
	%1	"STAND" ----- Standard "REAL" ----- Real "CINEMA" ----- Cinema "DYNAMIC" ----- Dynamic "DICOM" ----- DICOM "CUSTOM1" ----- "Image1" "CUSTOM2" ----- "Image2" "CUSTOM3" ----- "Image3" "CUSTOM4" ----- "Image4" "CUSTOM5" ----- "Image5" "CUSTOM6" ----- "Image6" "CUSTOM7" ----- "Image7" "CUSTOM8" ----- "Image8" "CUSTOM9" ----- "Image9" "CUSTOM10" ----- "Image10"
	Unacceptable	"Error Code" [CR] ----- When command is invalid in the given condition (such as being selected input) "?" [CR] ----- When unknown command is received

9.4.19 CR_IMGGMD Command

Command	"CR_IMGGMD" [CR]	
Details	Get setting status of Standard/Real/Cinema/Dynamic/DICOM in Image Gamma	
Response	Acceptable	"000_%1" [CR]
	%1	"STD" ----- Standard "REL" ----- Real "CNM" ----- Cinema "DYN" ----- Dynamic "DCM" ----- DICOM
	Unacceptable	"?" [CR]

9.5 PC Status Read Commands

9.5.1 CR_FSYNC Command

Command	"CR_FSYNC" [CR]	
Details	Get value of Fine Sync	
Response	Acceptable	"000_%1" [CR]
	%1	"0000" – "0031"
	Unacceptable	"Error Code" [CR] ----- When command is invalid in the given condition (such as being selected input) "?" [CR] ----- When unknown command is received

9.5.2 CR_TDOTS Command

Command	"CR_TDOTS" [CR]	
Details	Get value of Total Dots	
Response	Acceptable	"000_%1" [CR]
	%1	"mmmm" – "nnnn" (mmmm = Display area H + Position H) (nnnn = Maximum value less than 160 MHz of Dot Clock)
	Unacceptable	"Error Code" [CR] ----- When command is invalid in the given condition (such as being selected input) "?" [CR] ----- When unknown command is received

9.5.3 CR_H-POS Command

Command	"CR_H-POS" [CR]	
Details	Get value of Horizontal Position	
Response	Acceptable	"000_%1" [CR]
	%1	"0000" – "nnnn" (nnnn = Total Dots - Display Area H)
	Unacceptable	"Error Code" [CR] ----- When command is invalid in the given condition (such as being selected input) "?" [CR] ----- When unknown command is received

9.5.4 CR_V-POS Command

Command	"CR_V-POS" [CR]	
Details	Get value of Vertical Position	
Response	Acceptable	"000_%1" [CR]
	%1	"0000" – "nnnn" (nnnn = Total Line - Display Area V)
	Unacceptable	"Error Code" [CR] ----- When command is invalid in the given condition (such as being selected input) "?" [CR] ----- When unknown command is received

9.5.5 CR_CLAMP Command

Command	"CR_CLAMP" [CR]	
Details	Get value of Clamp	
Response	Acceptable	"000_%1" [CR]
	%1	"0000" – "4095"

	Unacceptable	"Error Code" [CR] ----- When command is invalid in the given condition (such as being selected input) "?" [CR] ----- When unknown command is received
--	--------------	--

9.5.6 CR_DDOTS Command

Command	"CR_DDOTS" [CR]	
Details	Get value of Display Dots	
Response	Acceptable	"000_%1" [CR]
	%1	"0256". "nnnn" (nnnn = Total Dots – Position H)
	Unacceptable	"Error Code" [CR] ----- When command is invalid in the given condition (such as being selected input) "?" [CR] ----- When unknown command is received

9.5.7 CR_DLINE Command

Command	"CR_DLINE" [CR]	
Details	Get value of Display Line	
Response	Acceptable	"000_%1" [CR]
	%1	"0100" – " nnnn" (nnnn = Total Line – Position V)
	Unacceptable	"Error Code" [CR] ----- When command is invalid in the given condition (such as being selected input) "?" [CR] ----- When unknown command is received

9.5.8 CR_SETPCADJ Command

Command	"CR_SETPCADJ" [CR]	
Details	Get PC signal for current system	
Response	Acceptable	"000_%1" [CR]
	%1	When input signal is PC Analog; "VGA1" ----- Indicates VGA1 is selected : "XGA1" ----- Indicates XGA1 is selected : "WXGA3" ----- Indicates WXGA3 is selected "1080i" ----- Indicates 1080i is selected "1035i" ----- Indicates 10350i is selected "720p" ----- Indicates 720p is selected "575p" ----- Indicates 575p is selected "480p" ----- Indicates 480p is selected "575i" ----- Indicates 575i is selected "480i" ----- Indicates 480i is selected "1080psf/24" ----- Indicates 1080psf/24 is selected "1080psf/25" ----- Indicates 1080psf/25 is selected "1080psf/30" ----- Indicates 1080psf/30 is selected "MODE1" ----- Indicates Mode1 is selected : "MODE10" ----- Indicates Mode10 is selected "EXT11" ----- EXT11 is selected : "EXT60" ----- EXT60 is selected * Error Code "101" [CR] is returned for no signal. * When input signal is not PC Analog, error code "101" is returned.
	Unacceptable	"?" [CR]

9.5.9 CR_ORGMODE Command

Command	"CR_ORGMODE" [CR]	
Details	Get the original signal of current selected Mode that is set in PC Adj. When MODE1- 10 or EXT11-60 is not selected, get the current signal.	
Response	Acceptable	"000_%1" [CR]
	%1	<p>When input signal is PC Analog;</p> <p>"VGA1" ----- Indicates signal is VGA1 "VGA2" ----- Indicates signal is VGA2 : : "XGA1" ----- Indicates signal is XGA1 : : "WXGA3" ----- Indicates signal is WXGA3 "1080i60" ----- Indicates signal is 1080i60 "1080i50" ----- Indicates signal is 1080i50 "1035i" ----- Indicates signal is 1035i "720p60" ----- Indicates signal is 720p60 "720p50" ----- Indicates signal is 720p50 "575p" ----- Indicates signal is 575p "480p" ----- Indicates signal is 480p "575i" ----- Indicates signal is 575i "480i" ----- Indicates signal is 480i "1080psf/24" ----- Indicates signal is 1080psf/24 "1080psf/25" ----- Indicates signal is 1080psf/25 "1080psf/30" ----- Indicates signal is 1080psf/30 "1080p24" ----- Indicates signal is 1080p24 "1080p25" ----- Indicates signal is 1080p25 "1080p30" ----- Indicates signal is 1080p30 "1080p50" ----- Indicates signal is 1080p50 "1080p60" ----- Indicates signal is 1080p60</p> <p>Note; To differentiate between 60Hz and 50Hz in 1080i and 720p, "60" or "50" is necessary to add to the parameter in this command * When input signal is not PC Analog, error code "101" is returned.</p>
	Unacceptable	"?" [CR]

9.5.10 CR_PCSTORE Command

Command	"CR_PCSTORE" [CR]	
Details	Get Free or Stored status of MODE1 - 5 in PC Adjust. Data consists of 10 bytes and each byte represents MODE1-10.(F:Free, S:Stored)	
Response	Acceptable	"000_%1" [CR]
	%1	<p>"FFFFFFFF" ----- ALL Free "SFFFFFFFF" ----- Mode1 is Stored, others are Free : "FFFFFFFFFS" ----- Mode10 is Stored, others are Free "SSSSSSSSSS" ----- ALL Stored</p>
	Unacceptable	<p>"Error Code" [CR] ----- When command is invalid in the given condition (such as being selected input) "?" [CR] ----- When unknown command is received</p>

9.6 Video Status Read Command

9.6.1 CR_SERSYS Command

Command	"CR_SERSYS" [CR]	
Details	Get currently selected signal. Value only when Input is video. (Invalid when Input is computer)	
Response	Acceptable	"000_%1" [CR]
	%1	"1080PSF/24" ----- 1080psf 24Hz "1080P60" ----- 1080p 60Hz "1080P50" ----- 1080p 50Hz "1080P30" ----- 1080p 30Hz "1080P25" ----- 1080p 25Hz "1080P24" ----- 1080p 24Hz "1080I60" ----- 1080i 60Hz "1080I50" ----- 1080i 50Hz "1035I" ----- 1035i "720P60" ----- 720p 60Hz "720P50" ----- 720p 50Hz "575P" ----- 575p "480P" ----- 480p "575I" ----- 575i (includes composite signal such as PAL) "480I" ----- 480i (includes composite signal such as NTSC) "NO_SIGNAL" ----- There is no signal *When 1080psf30 or 1080psf25 is inputted in System Auto, parameter same as 1080i60/1080i50 is returned.
	Unacceptable	"?" [CR]

9.7 Input Read Command

9.7.1 CR_INPUT Command

Command	"CR_INPUT" [CR]	
Details	Get selected INPUT No.	
Response	Acceptable	"000_%1" [CR]
	%1	"1" – "4"
	Unacceptable	"?" [CR]

9.7.2 CR_SOURCE Command

Command	"CR_SOURCE" [CR]	
Details	Get selected Source	
Response	Acceptable	"000_%1" [CR]
	%1	"DIGITAL" ----- DVI Input is selected "ANALOG" ----- ANALOG RGB is selected "VIDEO" ----- Video Input is selected "S-VIDEO" ----- S-VIDEO Input is selected "YPBPR" ----- Y/Pb/Pr Input is selected "SDI1" ----- DF-SDI1 Input is selected "SDI2" ----- DF-SDI2 Input is selected "HDCP" ----- HDCP Input is selected "HDMI" ----- HDMI Input is selected "SCART" ----- SCART Input is selected "BLANK" ----- without Source (LAN card) "NOCARD" ----- There is no board inserted
	Unacceptable	"Error Code" [CR] ----- When command is invalid in the given condition (such as being selected input) "?" [CR] ----- When unknown command is received

9.7.3 CR_SYSTEM Command

Command	"CR_SYSTEM" [CR]				
Details	Get selected System				
Response	%1	Acceptable	"000_%1" [CR]		
		Input is PC Analog	"VGA1" ----- indicates VGA1 is selected "VGA2" ----- indicates VGA2 is selected : : : "XGA1" ----- indicates XGA1 is selected : "WXGA3" ----- indicates WXGA3 is selected "1080I" ----- indicates 1080i is selected "1035I" ----- indicates 1035i is selected "720P" ----- indicates 720p is selected "575P" ----- indicates 575p is selected "480P" ----- indicates 480p is selected "575I" ----- indicates 575i is selected "480I" ----- indicates 480i is selected "1080PSF/24" ----- indicates 1080psf/24 is selected "1080PSF/25" ----- indicates 1080psf/25 is selected "1080PSF/30" ----- indicates 1080psf/30 is selected "MODE1" ----- indicates Mode1 is selected : "MODE10" ----- indicates Mode10 is selected "EXT11" ----- indicates EXT11 is selected : "EXT60" ----- indicates EXT60 is selected * Error Code "101" [CR] is returned for no signal		
			Input is PC-Digital/ AV-HDCP	"D-XGA1" ----- indicates D-XGA1 is selected : "D-WXGA3" ----- indicates D-WXGA3 is selected "D-1080I" ----- indicates D-1080i is selected "D-1035I" ----- indicates D-1035i is selected "D-720P" ----- indicates D-720p is selected "D-575P" ----- indicates D-575p is selected "D-480P" ----- indicates D-480p is selected "D-1080PSF/24" ----- indicates D-1080psf/24 is selected "D-1080PSF/25" ----- indicates D-1080psf/25 is selected "D-1080PSF/30" ----- indicates D-1080psf/30 is selected * Error Code "101" [CR] is returned for no signal	
				Input is HDMI	"D-XGA1" ----- indicates D-XGA1 is selected : "D-WXGA3" ----- indicates D-WXGA3 is selected "D-1080I" ----- indicates D-1080i is selected "D-1035I" ----- indicates D-1035i is selected "D-720P" ----- indicates D-720p is selected "D-575P" ----- indicates D-575p is selected "D-480P" ----- indicates D-480p is selected * Error Code "101" [CR] is returned for no signal
					Input is Y,Pb/Cb,Pr/Cr

	Input is Video or S-video	"AUTO" ----- indicates Auto is selected "NTSC" ----- indicates NTSC is selected "NTSC443" ----- indicates NTSC.4.43 is selected "PAL" ----- indicates PAL is selected "SECAM" ----- indicates SECAM is selected "PAL-M" ----- indicates PAL-M is selected "PAL-N" ----- indicates PAL-N is selected * Selected System is returned, whether or not signal is coming.
	Input is Dual-SDI	"D-480I" ----- indicates D-480i is selected "D-575I" ----- indicates D-575i is selected "D-1035I" ----- indicates D-1035i is selected "D-1080I" ----- indicates D-1080i is selected "D-720P" ----- indicates D-720p is selected "D-1080P" ----- indicates D-1080p is selected "D-1080PSF/24" ----- indicates D-1080psf/24 is selected "D-1080PSF/25" ----- indicates D-1080psf/25 is selected "D-1080PSF/30" ----- indicates D-1080psf/30 is selected * Error Code "101" [CR] is returned for no signal
	Unacceptable	"Error Code" [CR]

9.7.4 CR_SRCINP1 Command

Command	"CR_SRCINP1" [CR]	
Details	Get Source of Input1	
Response	Acceptable	"000_%1" [CR]
	%1	"DIGITAL" ----- in Computer mode "ANALOG" ----- in Computer mode "VIDEO" ----- in Video mode "S-VIDEO" ----- in Video mode "YPBPR" ----- in Component mode "SDI1" ----- in DF-SDI1 mode "SDI2" ----- in DF-SDI2 mode "HDCP" ----- in HDCP mode "HDMI" ----- in HDMI mode "SCART" ----- in SCART mode "BLANK" ----- There is no input source (LAN card) "NOCARD" ----- There is no board inserted
	Unacceptable	"?" [CR]

9.7.5 CR_SRCINP2 Command

Command	"CR_SRCINP2" [CR]	
Details	Get Source of Input 2	
Response	Acceptable	"000_%1" [CR]
	%1	The same data as CF_SRCINP1
	Unacceptable	"?" [CR]

9.7.6 CR_SRCINP3 Command

Command	"CR_SRCINP3" [CR]	
Details	Get Source of Input 3	
Response	Acceptable	"000_%1" [CR]
	%1	The same data as CF_SRCINP1
	Unacceptable	"?" [CR]

9.7.7 CR_SRCINP4 Command

Command	"CR_SRCINP3" [CR]	
Details	Get Source of Input 4	
Response	Acceptable	"000_%1" [CR]
	%1	The same data as CF_SRCINP1
	Unacceptable	"?" [CR]

9.7.8 CR_HMSLOT Command

Command	"CR_HMSLOT" [CR]	
Details	Get the total number of Slots(Inputs)	
Response	Acceptable	"000_%1" [CR]
	%1	"004"
	Unacceptable	"?" [CR]

9.7.9 CR_NMSLOT1 Command

Command	"CR_NMSLOT1" [CR]	
Details	Get the board name inserted to Slot 1	
Response	Acceptable	"000_%1" [CR]
	%1	"RGB-HDMI" ----- Input1/ New RGB&HDMI board "5BNC-VIDEO"----- Input2/ New Video board "HDCP-DVI2" ----- New HDCP & DVI Card "VGA" ----- VGA D-Sub board "NETWORK" ----- NETWORK board "5BNC" ----- Component board "DUAL-SDI" ----- HD&SD-SDI board "HDCP-DVI" ----- HDCP&DVI board "WARP" ----- Warp Card "NOTERMINAL" ----- There is no board inserted
	Unacceptable	"?" [CR]

9.7.10 CR_NMSLOT2 Command

Command	"CR_NMSLOT2" [CR]	
Details	Get the board name inserted to Slot 2	
Response	Acceptable	"000_%1" [CR]
	%1	The same data as CR_NMSLOT1
	Unacceptable	"?" [CR]

9.7.11 CR_NMSLOT3 Command

Command	"CR_NMSLOT3" [CR]	
Details	Get the board name inserted to Slot 3	
Response	Acceptable	"000_%1" [CR]
	%1	The same data as CR_NMSLOT1
	Unacceptable	"?" [CR]

9.7.12 CR_NMSLOT4 Command

Command	"CR_NMSLOT4" [CR]	
Details	Get the board name inserted to Slot 4	
Response	Acceptable	"000_%1" [CR]
	%1	The same data as CR_NMSLOT1
	Unacceptable	"?" [CR]

9.7.13 CR_IDSLOT1 Command

Command	"CR_IDSLOT1" [CR]	
Details	Get ID information on Slot 1. This command is used to recognize the inserted board and specify the valid Input source.	
Response	Acceptable	"000_%1" [CR]
	%1	<p>"00" ----- Video board Valid Input Source: VIDEO, YC, S-VIDEO</p> <p>"01" ----- D-sub board Valid Input Source: ANALOG</p> <p>"03" ----- Network board Valid Input Source: NONE (BLANK)</p> <p>"04" ----- Component board Valid Input Source: ANALOG, YPBPR</p> <p>"06" ----- HD-SDI board Valid Input Source: HD-SDI</p> <p>"07" ----- SD-SDI board Valid Input Source: SD-SDI</p> <p>"08" ----- DUAL-SDI board Valid Input Source: SDI1, SDI2</p> <p>"09" ----- HDCP-DVI board Valid Input Source: DIGITAL, ANALOG, HDCP, SCART</p> <p>"18" ----- New HDCP-DVI board Valid Input Source: DIGITAL, ANALOG, HDCP, SCART</p> <p>"19" ----- New Component & Video board Valid Input Source: ANALOG, YPBPR, VIDEO, S-VIDEO</p> <p>"10" ----- Warp card Valid Input Source: DIGITAL, HDCP</p> <p>"32" ----- On-board(DVI-D+D-Sub+HDMI) Valid Input Source: DIGITAL, ANALOG, HDCP, SCART, HDMI</p> <p>"42" ----- On-board(5BNC+S-video) Valid Input Source: ANALOG, YPBPR, VIDEO, S-VIDEO</p> <p>"99" ----- No board inserted</p>
	Unacceptable	"?" [CR]

9.7.14 CR_IDSLOT2 Command

Command	"CR_IDSLOT2" [CR]	
Details	Get ID information on Slot 2. This command is to recognize the inserted slot board and specify the valid Input source.	
Response	Acceptable	"000_%1" [CR]
	%1	The same as CR_IDSLOT1
	Unacceptable	"?" [CR]

9.7.15 CR_IDSLOT3 Command

Command	"CR_IDSLOT3" [CR]	
Details	Get ID information on Slot 3. This command is to recognize the inserted slot board and specify the valid Input source.	
Response	Acceptable	"000_%1" [CR]
	%1	The same as CR_IDSLOT1
	Unacceptable	"?" [CR]

9.7.16 CR_IDSLOT4 Command

Command	"CR_IDSLOT4" [CR]	
Details	Get ID information on Slot 4. This command is to recognize the inserted slot board and specify the valid Input source.	
Response	Acceptable	"000_%1" [CR]
	%1	The same as CR_IDSLOT1
	Unacceptable	"?" [CR]

9.8 Screen Status Read Commands

9.8.1 CR_SCREEN Command

Command	"CR_SCREEN" [CR]	
Details	Get currently selected screen image size	
Response	Acceptable	"000_%1" [CR]
	%1	"NORMAL" ----- Normal mode "WIDE" ----- Wide mode "FULL" ----- Full mode "TRUE" ----- True mode "CUSTOM" ----- Custom mode
	Unacceptable	"Error Code" [CR] ----- When command is invalid in the given condition (such as being selected input) "?" [CR] ----- When unknown command is received

9.8.2 CR_KYSTNMODE Command

Command	"CR_KYSTNMODE" [CR]	
Details	Get setting status of Keystone Store Mode	
Response	Acceptable	"000_%1" [CR]
	%1	"STR" ----- Store mode is "Store" "RST" ----- Store mode is "Reset"
	Unacceptable	"?" [CR] ----- When unknown command is received

9.8.3 CR_CEIL Command

Command	"CR_CEIL" [CR]	
Details	Get setting status of Ceiling	
Response	Acceptable	"000_%1" [CR]
	%1	"ON" ----- Ceiling projection is enabled "OFF" ----- Ceiling projection is disabled
	Unacceptable	"Error Code" [CR]

9.8.4 CR_REAR Command

Command	"CR_REAR" [CR]	
Details	Get setting status of Rear function	
Response	Acceptable	"000_%1" [CR]
	%1	"ON" ----- Rear projection is enabled "OFF" ----- Rear projection is disabled
	Unacceptable	"Error Code" [CR]

9.8.5 CR_VSCALE Command

Command	"CR_VSCALE" [CR]	
Details	Get setting status of V scale	
Response	Acceptable	"000_%1" [CR]
	%1	"-32" - "035"
	Unacceptable	"Error Code" [CR]

9.8.6 CR_VPOS Command

Command	"CR_VPOS" [CR]	
Details	Get setting status of V Position	
Response	Acceptable	"000_%1" [CR]
	%1	"-15" - "015"
	Unacceptable	"Error Code" [CR]

9.8.7 CR_HSCALE Command

Command	"CR_HSCALE" [CR]	
Details	Get setting status of H scale	
Response	Acceptable	"000_%1" [CR]
	%1	"-32" - "035"
	Unacceptable	"Error Code" [CR]

9.8.8 CR_HPOS Command

Command	"CR_HPOS" [CR]	
Details	Get setting status of H Position	
Response	Acceptable	"000_%1" [CR]
	%1	"-15" - "015"
	Unacceptable	"Error Code" [CR]

9.9 Lamp Status Read Commands

9.9.1 CR_LAMPREPL Command

Command	"CR_LAMPREPL" [CR]	
Details	Get the information of Lamp Replacement time	
Response	Acceptable	"000_%1" [CR]
	%1	<p>"2***" 2 ----- indicates 2 lamps are used in this model. * ----- indicates the status of each lamp in lamp number order. "Y" means the lamp operating time is over the threshold for lamp replacement, and "N" means it has not reached to.</p> <p>e.g. "2YN" ----- This indicates it is 2-lamp system, and Lamp #2 has not been reached to the replacement time while #1 should be replaced.</p>
	Unacceptable	"?" [CR]

9.9.2 CR_LAMPMODE Command

Command	"CR_LAMPMODE" [CR]	
Details	Get Lamp mode setting status	
Response	Acceptable	"000_%1" [CR]
	%1	<p>"FULL" ----- Lamp mode is set to 2-lamp (FULL) "LAMP1" ----- Lamp mode is set to Lamp1 "LAMP2" ----- Lamp mode is set to Lamp2</p>
	Unacceptable	"?" [CR]

9.9.3 CR_AUTOLAMPCTRL Command

Command	"CR_AUTOLAMPCTRL" [CR]	
Details	Get selected Lamp control mode	
Response	Acceptable	"000_%1" [CR]
	%1	<p>"NORMAL" ----- NORMAL is selected. "ECO1" ----- ECO1 is selected. "ECO2" ----- ECO2 is selected.</p>
	Unacceptable	"Error Code" [CR]

9.9.4 CR_LAMPSTS Command

Command	"CR_LAMPSTS" [CR]	
Details	Get the information of Lamp lighting status	
Response	Acceptable	"000_%1" [CR]
	%1	<p>"2***" The first character indicates 2 lamps are used in this model. The following characters indicate each lamp status in lamp number order as showed below. "I" ----- Lamp is ON "O" ----- Lamp is OFF "X" ----- Lamp Failure</p> <p>e.g. "2IO" ----- This indicates it is 2-lamps system, Lamp #1 is ON, and #2 is OFF.</p>
	Unacceptable	"?" [CR]

9.9.5 CR_INFLAMP Command

Command	"CR_INFLAMP" [CR]	
Details	Get Lamp mode switching status	
Response	Acceptable	"000_%1" [CR]
	%1	"NML" ----- in Normal status (lamp switching operation is not active.)
	Unacceptable	"?" [CR]

9.9.6 CR_PROJH Command

Command	"CR_PROJH" [CR]	
Details	Get total running time of projector (in hours)	
Response	Acceptable	"000_%1" [CR]
	%1	"0000000" – "0099999"
	Unacceptable	"?" [CR]

9.9.7 CR_HMLAMP Command

Command	"CR_HMLAMP" [CR]	
Details	Get total lamp number	
Response	Acceptable	"000_%1" [CR]
	%1	"002"
	Unacceptable	"?" [CR]

9.9.8 CR_LAMPH Command

Command	"CR_LAMPH" [CR]	
Details	Get Lamp running time (in hours) * return actual lamp running time	
Response	Acceptable	"000_%1_%2_%3_%4" [CR]
	%1_%2 %3_%4	<p>Lamp 1 data comes first, and then one space, after that lamp 2 data is followed. %1 = lamp No.1 %2 = lamp No.2 %3 = lamp No.3 %4 = lamp No.4</p> <p>In the case of 2-lamps model, % 1 and % 2 are only used (There are no % 3 and % 4)</p> <p>e.g.; "0410_0410_0410_0410" [CR] → Lamp No.1 = 410 Hours Lamp No.2 = 410 Hours Lamp No.3 = 410 Hours Lamp No.4 = 410 Hours</p> <p>Note; -each data shall be 4 digits. -"9999" is returned for 10000 hours or more.</p>
	Unacceptable	"?" [CR]

9.9.9 CR_LAMPINTERVAL Command

Command	"CR_LAMPINTERVAL" [CR]	
Details	Get setting status of Lamp interval	
Response	Acceptable	"000_%1" [CR]
	%1	"AUTO" ----- Auto is selected "0024"----- 24 Hours is selected "0200"----- 200 Hours is selected "0500"----- 500 Hours is selected "1000"----- 1000 Hours is selected "2000"----- 2000 Hours is selected "OFF" ----- Off is selected
	Unacceptable	"?" [CR]

9.9.10 CR_LAMPLIFECNTRL Command

Command	"CR_LAMPLIFECNTRL" [CR]	
Details	Get setting status of Lamp life control. (Available only in the normal Power ON status)	
Response	Acceptable	"000_%1" [CR]
	%1	"MODE1" ----- Mode1 is selected "MODE2"----- Mode2 is selected
	Unacceptable	"Error Code" [CR]

9.10 Setting Status Read Commands

9.10.1 CR_LANG Command

Command	"CR_LANG" [CR]	
Details	Get selected language	
Response	Acceptable	"000_%1" [CR]
	%1	"ENG" ----- English is selected "DEU" ----- German is selected "FRA" ----- French is selected "ITA" ----- Italian is selected "ESP" ----- Spanish is selected "POR" ----- Portuguese is selected "NED" ----- Dutch is selected "SVE" ----- Swedish is selected "CHI" ----- Chinese is selected "KOR" ----- Korean is selected "JPN" ----- Japanese is selected "RUS" ----- Russian is selected
	Unacceptable	"?" [CR]

9.10.2 CR_SIMPLEMENU Command

Command	"CR_SIMPLEMENU" [CR]	
Details	Get setting status of Simple menu	
Response	Acceptable	"000_%1" [CR]
	%1	"ON" ----- On is selected "OFF" ----- Off is selected
	Unacceptable	"Error Code" [CR]

9.10.3 CR_MENUSIZE Command

Command	"CR_MENUSIZE" [CR]	
Details	Get setting status of Menu size	
Response	Acceptable	"000_%1" [CR]
	%1	"NORMAL" ----- Normal is selected "DOUBLE" ----- Double is selected
	Unacceptable	"Error Code" [CR]

9.10.4 CR_DISP Command

Command	"CR_DISP" [CR]	
Details	Get Display setting status	
Response	Acceptable	"000_%1" [CR]
	%1	"ON" ----- Display is set to ON. "CNTDWN OFF" ----- Display is set to Count down OFF. "OFF" ----- Display is set to OFF.
	Unacceptable	"?" [CR]

9.10.5 CR_BACKGND Command

Command	"CR_BACKGND" [CR]	
Details	Get setting status of Screen for no signal	
Response	Acceptable	"000_%1" [CR]
	%1	"BLUE" ----- Blue Back is selected "USER" ----- User is selected "BLACK" ----- Black Back is selected
	Unacceptable	"Error Code" [CR]

9.10.6 CR_LOGO Command

Command	"CR_LOGO" [CR]	
Details	Get Logo setting status	
Response	Acceptable	"000_%1" [CR]
	%1	"DFLT" ----- Default Logo is enabled "USER" ----- User is enabled "OFF" ----- Off is enabled
	Unacceptable	"?" [CR]

9.10.7 CR_LOGOLOCK Command

Command	"CR_LOGOLOCK" [CR]	
Details	Get setting status of Logo Lock function	
Response	Acceptable	"000_%1" [CR]
	%1	"ON" ----- Logo Lock is ON "OFF" ----- Logo Lock is OFF
	Unacceptable	"Error Code" [CR]

9.10.8 CR_FANSPEED Command

Command	"CR_FANSPEED" [CR]	
Details	Get currently selected Fan Control Speed	
Response	Acceptable	"000_%1" [CR]
	%1	"MAX" ----- Max speed of Fan Control is selected "NOR" ----- Normal speed of Fan Control is selected
	Unacceptable	"?" [CR]

9.10.9 CR_RCODE Command

Command	"CR_RCODE" [CR]	
Details	Get currently selected Remote Control code	
Response	Acceptable	"000_%1" [CR]
	%1	"001" ----- Code1 : "008" ----- Code8
	Unacceptable	"?" [CR]

9.10.10 CR_RSENS Command

Command	"CR_RSENS" [CR]	
Details	Get selected location of infrared remote receiver of remote control	
Response	Acceptable	"000_%1" [CR]
	%1	"ALL" ----- Front and back and top parts are valid "FRONTTOP" ----- Both front and top parts are valid "BACKTOP" ----- Both back and top parts are valid "FRONTBACK" ----- Both front and back parts are valid "FRONT" ----- Only front part is valid "TOP" ----- Only top part is valid "BACK" ----- Only back part is valid
	Unacceptable	"?" [CR]

9.10.11 CR_P-MANE Command

Command	"CR_P-MANE" [CR]	
Details	Get setting status of Power management	
Response	Acceptable	"000_%1" [CR]
	%1	"OFF" ----- Power Management is disabled "READY" ----- Power Management is set to Ready "SHUTDOWN" -----Power Management is set to Shut Down mode
	Unacceptable	"?" [CR]

9.10.12 CR_P-MANETIME Command

Command	"CR_P-MAETIME" [CR]	
Details	Get setting time for starting Power Management function	
Response	Acceptable	"000_%1" [CR]
	%1	"001 – 030" ----- 1 to 30 minutes
	Unacceptable	"?" [CR]

9.10.13 CR_ONSTA Command

Command	"CR_ON-STA" [CR]	
Details	Get Power ON Start setting status	
Response	Acceptable	"000_%1" [CR]
	%1	"ON" ----- Power ON Start is set to ON. "OFF" ----- Power ON Start is set to OFF.
	Unacceptable	"?" [CR]

9.10.14 CR_SECURITY Command

Command	"CR_SECURITY" [CR]	
Details	Get ON/OFF setting status of Security on menu.	
Response	Acceptable	"000_%1" [CR]
	%1	"ON" ----- PJ is locked "OFF" ----- PJ is not locked.
	Unacceptable	"Error Code" [CR]

9.10.15 CR_PJLOCKNOW Command

Command	"CR_PJLOCKNOW" [CR]	
Details	Get actual setting status of PIN code lock	
Response	Acceptable	"000_%1" [CR]
	%1	"LOCK" ----- PJ is locked PIN code lock is set to ON1/ON2 on the menu and PJ PIN code is not entered, therefore PJ is actually locked. "FREE" ----- PJ is unlocked (either A or B) A) PJ lock is set to OFF on the menu B) PJ lock is set to ON1/ON2 on the menu, but PIN code Lock mode is canceled because PJ PIN code is entered.
	Unacceptable	"Error Code" [CR]

9.10.16 CR_PJLOCMENU Command

Command	"CR_PJLOCKMENU" [CR]	
Details	Get ON/OFF setting status of PIN code lock on menu	
Response	Acceptable	"000_%1" [CR]
	%1	"ON1" ----- PIN code lock ON 1 is set on the menu "ON2" ----- PIN code lock ON 2 is set on the menu "OFF" ----- PIN code lock OFF is set on the menu
	Unacceptable	"Error Code" [CR]

9.10.17 CR_FILH Command

Command	"CR_FILH" [CR]	
Details	Get Filter used time	
Response	Acceptable	"000_%1" [CR]
	%1	"00000 - 99999"
	Unacceptable	"Error Code" [CR]

9.10.18 CR_FILCOND Command

Command	"CR_FILCOND" [CR]	
Details	Get status of filter clog	
Response	Acceptable	"000_%1" [CR]
	%1	"CLOG" = Filter is clogged "WARN" = Filter is nearly clogged "CLEAN" = Filter is not clogged
	Unacceptable	"Error Code" [CR]

9.10.19 CR_FILREPL Command

Command	"CR_FILREPL" [CR]	
Details	Get status of Filter cleaning / replacement time	
Response	Acceptable	"000_%1" [CR]
	%1	"1Y"-----Filter Exchange time is over value of Filter Message. "1N"--Filter Exchange time is not over value of Filter Message.
	Unacceptable	"Error Code" [CR]

9.10.20 CR_FILTIMER Command

Command	"CR_FILTIMER" [CR]	
Details	Get time to display Filter cleaning / replacement warning on screen	
Response	Acceptable	"000_%1" [CR]
	%1	"1000" ----- Display message by 1000h used. "2000" ----- Display message by 2000h used. "3000" ----- Display message by 3000h used. "OFF" ----- Off(Warning display is not displayed)
	Unacceptable	"Error Code" [CR]

9.10.21 CR_FILREMAIN Command

Command	"CR_FILREMAIN" [CR]	
Details	Get remaining number of usable Filter scroll	
Response	Acceptable	"000_%1" [CR]
	%1	"09" = Remaining number of usable Filter scroll : 9 times : "00" = Remaining number of usable Filter scroll : 0 time
	Unacceptable	"Error Code" [CR]

9.10.22 CR_TESTPAT Command

Command	"CR_TESTPAT" [CR]	
Details	Get setting status of Test pattern	
Response	Acceptable	"000_%1" [CR]
	%1	"COLOR" ----- Color bar is displayed "GRAD1" ----- 16step(white→black) is displayed "GRAD2" ----- 16step(white←black) is displayed "GRAD3" ----- 16step(white↓black) is displayed "GRAD4" ----- 16step(white↑black) is displayed "WHITE" ----- All white is displayed "BLACK" ----- All black is displayed "CROSS" ----- Cross is displayed "OFF" ----- Test pattern display is not displayed
	Unacceptable	"Error Code" [CR]

9.10.23 CR_KEYDIS Command

Command	"CR_KEYDIS" [CR]	
Details	Get setting status of RC/KEY use limitation (valid or invalid)	
Response	Acceptable	"000_%1" [CR]
	%1	"NONE" ----- RC & KEY are valid "RC" ----- RC is invalid "KEY" ----- KEY is invalid
	Unacceptable	"?" [CR]

9.10.24 CR_SHUTRCPROT Command

Command	"CR_SHUTRCPROT" [CR]	
Details	Get status if Shutter can be controlled by R/C	
Response	Acceptable	"000_%1" [CR]
	%1	"ON" ----- Shutter is not controllable by R/C "OFF" ----- Shutter is controllable by R/C
	Unacceptable	"Error Code" [CR]

9.10.25 CR_SHUTKEYPROT Command

Command	"CR_SHUTKEYPROT" [CR]	
Details	Get status if Shutter can be controlled by key on the top panel	
Response	Acceptable	"000_%1" [CR]
	%1	"ON" ----- Shutter is not controllable by key on the top panel "OFF" ----- Shutter is controllable by key on the top panel
	Unacceptable	"Error Code" [CR]

9.10.26 CR_SHUTH Command

Command	"CR_SHUTH" [CR]	
Details	Get time setting to start the shutter management	
Response	Acceptable	"000_%1" [CR]
	%1	"005" ----- 5 minutes "006" ----- 6 minutes : "179" ----- 179 minutes "180" ----- 180 minutes
	Unacceptable	"Error Code" [CR]

9.10.27 CR_PIP Command

Command	"CR_PIP" [CR]	
Details	Get setting status of "Picture in Picture"	
Response	Acceptable	"000_%1" [CR]
	%1	"OFF" ----- Off is selected "USER1" ----- User1 is selected "USER2" ----- User 2 is selected "USER3" ----- User3 is selected "USER4" ----- User4 is selected "USER5" ----- User5 is selected
	Unacceptable	"Error Code" [CR]

9.10.28 CR_PIPMAININP Command

Command	"CR_PIPMAININP" [CR]	
Details	Get Input and Source of "Picture in Picture". (Main picture)	
Response	Acceptable	"000_%1_%2" [CR]
	%1	"1" ----- Input1 is selected "2" ----- Input2 is selected "3" ----- Input3 is selected "4" ----- Input4 is selected
	%2	"DIGITAL" ----- DVI Input is selected "ANALOG" ----- ANALOG RGB is selected "VIDEO" ----- Video Input is selected "S-VIDEO" ----- S-VIDEO Input is selected "YPBPR" ----- Y/Pb/Pr Input is selected "SDI1" ----- SDI1 Input is selected "SDI2" ----- SDI2 Input is selected "SCART" ----- SCART Input is selected "HDCP" ----- HDCP Input is selected "HDMI" ----- HDMI Input is selected
	Unacceptable	"Error Code" [CR]

9.10.29 CR_PIPSUBINPU Command

Command	"CR_PIPSUBINP" [CR]	
Details	Get Input and Source of "Picture in Picture". (Sub picture)	
Response	Acceptable	"000_%1_%2" [CR]
	%1	"1" ----- Input1 is selected "2" ----- Input2 is selected "3" ----- Input3 is selected "4" ----- Input4 is selected
	%2	"DIGITAL" ----- DVI Input is selected "ANALOG" ----- ANALOG RGB is selected "VIDEO" ----- Video Input is selected "S-VIDEO" ----- S-VIDEO Input is selected "YPBPR" ----- Y/Pb/Pr Input is selected "SDI1" ----- SDI1 Input is selected "SDI2" ----- SDI2 Input is selected "SCART" ----- SCART Input is selected "HDCP" ----- HDCP Input is selected "HDMI" ----- HDMI Input is selected
	Unacceptable	"Error Code" [CR]

9.10.30 CR_PIPSIZE Command

Command	"CR_PIPSIZE" [CR]	
Details	Get picture size of "Picture in Picture". (Sub picture)	
Response	Acceptable	"000_%1_%2" [CR]
	%1	"1" ----- 10% is selected(Main size) "2" ----- 20% is selected(Main size) "3" ----- 30% is selected(Main size) "4" ----- 40% is selected(Main size) "5" ----- 50% is selected(Main size) "6" ----- 60% is selected(Main size) "7" ----- 70% is selected(Main size) "8" ----- 80% is selected(Main size) "9" ----- 90% is selected(Main size) "10" ----- 100% is selected(Main size)
	%2	"1" ----- 10% is selected(Sub size) "2" ----- 20% is selected(Sub size) "3" ----- 30% is selected(Sub size) "4" ----- 40% is selected(Sub size) "5" ----- 50% is selected(Sub size)
	Unacceptable	"Error Code" [CR]

9.10.31 CR_PIPFRAMELOCK Command

Command	"CR_PIPFRAMELOCK" [CR]	
Details	Get setting status of Frame lock of "Picture in Picture".	
Response	Acceptable	"000_%1" [CR]
	%1	"MAIN" ----- Main picture is selected "SUB" ----- Sub picture is selected
	Unacceptable	"Error Code" [CR]

9.10.32 CR_PIPSTORE Command

Command	"CR_PIPSTORE" [CR]	
Details	Get status (Free or Stored) of User1-User5 of "Picture in Picture".	
Response	Acceptable	"000_%1" [CR]
	%1	"SFFFF" ----- Only User1 is Stored, others are Free : "FFFFS" ----- Only User5 is Stored, others are Free "SSSSS" ----- All Stored
	Unacceptable	"Error Code" [CR]

9.10.33 CR_EDGEBLENDING Command

Command	"CR_EDGEBLENDING" [CR]	
Details	Get setting status of Edge blending	
Response	Acceptable	"000_%1" [CR]
	%1	"ON" ----- On is selected "OFF" ----- Off is selected
	Unacceptable	"Error Code" [CR]

9.10.34 CR_EDGEBLENDING Command

Command	"CR_BLEND" [CR]	
Details	Get all values of width of Edge blending	
Response	Acceptable	"000_%1_%2_%3_%4" [CR]
	%1, %2, %3, %4	<p>Left width data comes first, and then one space, after that right width data is followed.</p> <p>%1 = Left width %2 = Right width %3 = Top width %4 = Bottom width</p> <p>e.g. "100_100_100_100"[CR] Left = width 100 Right = width 100 Top = width 100 Bottom = width 100</p>
	Unacceptable	"Error Code" [CR]

9.10.35 CR_BLENDBLK Command

Command	"CR_BLENDBLK" [CR]	
Details	Get all values of Black level of Edge blending	
Response	Acceptable	"000_%1_%2_%3" [CR]
	%1, %2, %3	<p>Data of red comes first, and then one space, after that data of green is followed.</p> <p>%1 = Red %2 = Green %3 = Blue</p> <p>e.g. "0100_0100_0100"[CR] Red = 100 Green = 100 Blue = 100</p>
	Unacceptable	"Error Code" [CR]

9.10.36 CR_BLENDTESTPAT Command

Command	"CR_BLENDTESTPAT" [CR]	
Details	Get setting status of Test pattern of Edge blending	
Response	Acceptable	"000_%1" [CR]
	%1	<p>"ON" ----- On is selected "OFF" ----- Off is selected</p>
	Unacceptable	"Error Code" [CR]

9.10.37 CR_COLORMATCHING Command

Command	"CR_COLORMATCHING" [CR]	
Details	Get setting status of Color matching	
Response	Acceptable	"000_%1" [CR]
	%1	<p>"ON" ----- On is selected "OFF" ----- Off is selected</p>
	Unacceptable	"Error Code" [CR]

9.10.38 CR_CMMSXY_%1 Command

Command	"CR_CMMSXY_%1" [CR]	
Details	Get "x","y" value of Measured of Color matching	
Response	Acceptable	"000_%2_%3" [CR]
	%1	"RED" ----- value of Red is selected "GREEN" ----- value of Green is selected "BLUE" ----- value of Blue is selected "WHITE" ----- value of White is selected "HALFWHITE" ----- value of Half white is selected
	%2	"0000"-1000"----- "x" value of color of %1
	%3	"0000"-1000"----- "y" value of color of %1
	Unacceptable	"Error Code" [CR]

9.10.39 CR_CMMSL_%1 Command

Command	"CR_CMMSL_%1" [CR]	
Details	Get "L" value of Measured of Color matching	
Response	Acceptable	"000_%2" [CR]
	%1	"RED" ----- value of Red is selected "GREEN" ----- value of Green is selected "BLUE" ----- value of Blue is selected "WHITE" ----- value of White is selected "HALFWHITE" ----- value of Half white is selected
	%2	"0000"-1000"----- "L" value of color of %1
	Unacceptable	"Error Code" [CR]

9.10.40 CR_CMTGXY_%1 Command

Command	"CR_CMTGXY_%1" [CR]	
Details	Get "x""y" value of Target of Color matching	
Response	Acceptable	"000_%2" [CR]
	%1	"RED" ----- value of Red is selected "GREEN" ----- value of Green is selected "BLUE" ----- value of Blue is selected "WHITE" ----- value of White is selected "CYAN" ----- value of Cyan is selected "MAGENTA" ----- value of Magenta is selected "YELLOW" ----- value of Yellow is selected
	%2	"0000"-1000"----- "x" value of color of %1
	%3	"0000"-1000"----- "y" value of color of %1
	Unacceptable	"Error Code" [CR]

9.10.41 CR_CMTGG_%1 Command

Command	"CR_CMMTGG_%1" [CR]	
Details	Get "g" value of Target of Color matching	
Response	Acceptable	"000_%2" [CR]
	%1	"RED" ----- value of Red is selected "GREEN" ----- value of Green is selected "BLUE" ----- value of Blue is selected "WHITE" ----- value of White is selected "CYAN" ----- value of Cyan is selected "MAGENTA" ----- value of Magenta is selected "YELLOW" ----- value of Yellow is selected
	%2	"0000"-1000"----- "g" value of color of %1
	Unacceptable	"Error Code" [CR]

9.10.42 CR_CMAUTOTESTPAT Command

Command	"CR_CMAUTOTESTPAT" [CR]	
Details	Get setting status of Auto test pattern of Color matching	
Response	Acceptable	"000_%1" [CR]
	%1	"ON" ----- On is selected "OFF" ----- Off is selected
	Unacceptable	"Error Code" [CR]

9.10.43 CR_CMMSTESTPAT Command

Command	"CR_CMMSTESTPAT" [CR]	
Details	Get setting status of Test pattern(Measured) of Color matching	
Response	Acceptable	"000_%1" [CR]
	%1	"RED" ----- Red is displayed "GREEN" ----- Green is displayed "BLUE" ----- Blue is displayed "WHITE" ----- White is displayed "HALFWHITE" ----- Half white is displayed "OFF" ----- Test pattern display is not displayed
	Unacceptable	"Error Code" [CR]

9.10.44 CR_CMTGTESTPAT Command

Command	"CR_CMTGTESTPAT" [CR]	
Details	Get setting status of Test pattern(Target) of Color matching	
Response	Acceptable	"000_%1" [CR]
	%1	"RED" ----- Red is displayed "GREEN" ----- Green is displayed "BLUE" ----- Blue is displayed "WHITE" ----- White is displayed "CYAN" ----- Cyan is displayed "MAGENTA" ----- Magenta is displayed "YELLOW" ----- Yellow is displayed "OFF" ----- Test pattern display is not displayed
	Unacceptable	"Error Code" [CR]

9.10.45 CR_DYNAMICBLACK Command

Command	"CR_DYNAMICBLACK" [CR]	
Details	Get setting status of DynamicBlack	
Response	Acceptable	"000_%1" [CR]
	%1	"LOW" ----- Low is selected "HIGH" ----- High is selected "OFF" ----- Off is selected
	Unacceptable	"Error Code" [CR]

9.10.46 CR_HDMISETUP Command

Command	"CR_HDMISETUP" [CR]	
Details	Get setting status of HDMI setup	
Response	Acceptable	"000_%1" [CR]
	%1	"NORMAL" ----- Normal is selected "ENHANCED" ----- Enhanced is selected
	Unacceptable	"Error Code" [CR]

9.11 Other Status Read Commands

9.11.1 CR_STATUS Command

Command	"CR_STATUS" [CR]	
Details	Get operating status of Projector Same as "CR0" in basic command except error code follows it.	
Response	Acceptable	"000_%1" [CR]
	%1	"00" = Power ON "80" = Standby "40" = Countdown in process "20" = Cooling Down in process "10" = Power Failure "28" = Cooling Down in process due to abnormal temperature "88" = Standby after Cooling Down due to abnormal temperature "02" = Invalid RS-232C Command "24" = Power Save/Cooling Down in process "04" = Power Save "21" = Cooling Down in process after turned Off due to lamp failure "81" = Standby after Cooling Down due to lamp failure "2C" = Cooling Down in process after Power Off due to Shutter management "8C" = Standby after Cooling Down due to Shutter management
	Unacceptable	"Error Code" [CR]

9.11.2 CR_SIGNAL Command

Command	"CR_SIGNAL" [CR]	
Details	Get status if there is any signal or not	
Response	Acceptable	"000_%1" [CR]
	%1	"ON" ----- There is signal "OFF" ----- There is no signal
	Unacceptable	"?" [CR]

9.11.3 CR_VMUTE Command

Command	"CR_VMUTE" [CR]	
Details	Get Video mute setting status	
Response	Acceptable	"000_%1" [CR]
	%1	"ON" ----- Video mute is set to ON (Shutter Close). "OFF" ----- Video mute is set to OFF (Shutter Open).
	Unacceptable	"?" [CR]

9.11.4 CR_FREEZE Command

Command	"CR_FREEZE" [CR]	
Details	Get Freeze setting status	
Response	Acceptable	"000_%1" [CR]
	%1	"ON" ----- Freeze is set to ON. "OFF" ----- Freeze is set to OFF.
	Unacceptable	"?" [CR]

9.11.5 CR_P-TIMER Command

Command	"CR_P-TIMER" [CR]	
Details	Get Presentation Timer operating status	
Response	Acceptable	"000_%1" [CR]
	%1	"ON" ----- Presentation Timer is ongoing. "STOP" ----- Presentation Timer is paused. "OFF" ----- Presentation Timer is not active.
	Unacceptable	"?" [CR]

9.11.6 CR_TEMPWARN Command

Command	"CR_TEMPWARN" [CR]	
Details	Get the information about the temperature inside the projector (close to the abnormal or in the abnormal status/in the safe temperature level/abnormal status is not detected). It is possible to get the information about more than one sensor all at once if it is applicable.	
Response	Acceptable	"000_%1" [CR]
	%1	"* _*" Sensor 1 data comes first, and then one space, after that sensor 2 data is followed. Each data is as below: "W"--- in or close to the abnormal temp. (Warning Temp.) "S"--- in the safe level of temperature (Safe Temp.) "N"--- the given sensor does not detect abnormal temp. e.g. "S_W" [CR] indicates that the temperature detected at Sensor 1 is in the safe level while Sensor 2 in the abnormal temperature.
	Unacceptable	"?" [CR]

9.11.7 CR_TEMPFAIL Command

Command	"CR_TEMPFAIL" [CR]	
Details	Get the temperature inside the projector when the abnormal status occurs. It is possible to get the temperatures for more than one sensor all at once if it is applicable.	
Response	Acceptable	"000_%1" [CR]
	%1	<p>e.g. "_31.5F"[CR] _ indicates a space. When the temperature goes under 0, the first character is "-", not a space, as in "-05.5F". With more than one temperature sensors installed, projector returns the responses for each sensor in a row.</p> <p>e.g. "_31.5F_35.2S" [CR] The first data indicates sensor 1 data, then one space, and sensor 2 data is followed. Last character in each data indicates the sensor's status. In the abnormal temperature ----- "F" In the safe level of temperature ----- "S" Neither in or close to the abnormal temp. ----- "N"</p> <p>The second example above indicates that the temperature detected by sensor 1 is 31.5 which means in the abnormal temperature, and at sensor 2 is 32.5 degrees which is in the safe temperature.</p> <p>When the abnormal temperature status is not occurred the data should be "_00.0S". When the projector is reset, "_00.0S" is set. Every time abnormal temperature status is detected, it renews the data and returns it. It only returns the renewed data of the latest abnormal temperature and the previous data is cleared.</p>
	Unacceptable	"?" [CR]

9.11.8 CR_SERIALNO Command

Command	"CR_SERIALNO" [CR]	
Details	Get value of the serial number.	
Response	Acceptable	"000_%1" [CR]
	%1	Eight digits of alphanumeric characters
	Unacceptable	"?" [CR]

9.11.9 CR_SHUTCOND Command

Command	"CR_SHUTCOND" [CR]	
Details	Get setting status of Shutter	
Response	Acceptable	"000_%1" [CR]
	%1	<p>"SAFE" ----- Shutter operation is normal. "FAIL" ----- Shutter operation is abnormal.</p>
	Unacceptable	"?" [CR]

10 . Command with Address Specification

10.1. Overview

- Commands with address are used to remote control more than one projector through RS-232C by a computer.
- The command with address is defined as a single command per line that starts with "A" and ends with carriage return (0x0D).
- When a projector receives carriage return (0x0D), it starts decoding.
- The address such as "A001" is prefixed to the Basic Serial Command or Expand Serial Command already mentioned.

e.g.) Functional Execution Command: "A001C05" [CR]

e.g.) Status Read Command: "A001CR0" [CR]

- Projector has the function to set up its own address in Service mode.

Initial setting value is "No.001"

Available range of the value is "001" to "999"

- It clears the data in the receive buffer in the following cases.
 - When receiving LF (0x0A) or EOF (0x1A)
 - When it takes more than one second to receive a single command.
(Until receiving carriage return after the reception of the first data)
- It returns the response within 60ms.

10.2. Functional Execution Command with address

10.2.1. Format

- 1) PC issues a command in the format below:

"A" **Address** "C" **Command** [CR]

or

"A" **Address** "CF_" **Command** "_" **Parameter** [CR]

Address: 3-digit number ("001" – "999")

Commands with "FFF" as the address are valid to all projectors.

Command: string (Refer to Basic and Expand Serial Command)

- 2) The only projector with the appropriate address decodes the received command, and when it is ready to receive the next command, it returns the response.

[ACK] [CR]: When receiving Functional Execution Command (0x06, 0x0D)

" – " **[CR]:** When the received data cannot be decoded

However, when the address is "FFF", the projector executes the function but does not return the response.

10.2.2. When the command pipelining is needed

When it needs command pipelining, the operation is the same as the remote control as below:

- 1) Sending-side system issues commands every 100ms
- 2) When receiving an applicable command, the function is executed repeatedly for 120ms.
- 3) When receiving the same command in a row within 120ms, the function is repeatedly executed for another 120ms from the moment of the second command reception.
- 4) When there is no incoming command after 120ms, the execution of pipelining is stopped.
- 5) When the projector receives other command within 120ms, the execution of pipelining is stopped.

10.3. Status Read Command with Address

10.3.1. Format

- 1) PC issues a command in the format as below:

"A" Address "CR" Command [CR]

or

"A" Address "CR_" Command [CR]

Address: 3-digit number ("001" – "999")

Command: string (Refer to Basic and Expand Serial Commands)

The only projectors that have the address matching with the one in the received data decode the command, and it returns required data.

Required Data [CR]

Required Data: String (Refer to Basic Status Read Commands)

- 3) When the received data cannot be decoded, it returns "? " [CR]