

# EXPAND SERIAL COMMAND FUNCTIONAL SPECIFICATIONS

PLC-XF1000

Ver.1.00

SANYO Electric Co., Ltd  
DS Company  
Projector Division

## CONTENTS

<b>1.</b>	<b>Overview .....</b>	<b>8</b>
<b>2.</b>	<b>Serial Interface Specification .....</b>	<b>8</b>
	<b>2.1 Transfer Specification .....</b>	<b>8</b>
	<b>2.2 Connection .....</b>	<b>8</b>
<b>3.</b>	<b>Notes for communication .....</b>	<b>9</b>
<b>4.</b>	<b>Notation .....</b>	<b>10</b>
<b>5.</b>	<b>Functional Execution Command Table .....</b>	<b>11</b>
	<b>5.1 Image Command Table .....</b>	<b>11</b>
	<b>5.2 PC Control Command Table .....</b>	<b>11</b>
	<b>5.3 Input Control Command Table .....</b>	<b>12</b>
	<b>5.4 Screen Command Table .....</b>	<b>12</b>
	<b>5.5 Lamp Command Table .....</b>	<b>12</b>
	<b>5.6 Setting Command Table .....</b>	<b>13</b>
	<b>5.7 Other Command Table .....</b>	<b>13</b>
	<b>5.8 HD-data-wireless Command Table .....</b>	<b>13</b>
<b>6.</b>	<b>Status Read Command Table .....</b>	<b>14</b>
	<b>6.1 Image Status Read Command Table .....</b>	<b>14</b>
	<b>6.2 PC Status Read Command Table .....</b>	<b>14</b>
	<b>6.3 Video Status Read Command Table .....</b>	<b>14</b>
	<b>6.4 Input Status Read Command Table .....</b>	<b>15</b>
	<b>6.5 Screen Status Read Command Table .....</b>	<b>15</b>
	<b>6.6 Lamp Status Read Command Table .....</b>	<b>15</b>
	<b>6.7 Setting Status Read Command Table .....</b>	<b>16</b>
	<b>6.8 Other Status Read Command Table .....</b>	<b>16</b>
	<b>6.9 HD data wireless Status Read Command Table .....</b>	<b>16</b>
<b>7.</b>	<b>Error Code Table .....</b>	<b>17</b>
<b>8.</b>	<b>Functional Execution Command .....</b>	<b>18</b>
	<b>8.1 Format .....</b>	<b>18</b>
	<b>8.2 Transfer Example .....</b>	<b>18</b>
	<b>8.3 Operation Requirements .....</b>	<b>18</b>
	<b>8.4 Image Command .....</b>	<b>19</b>
	<b>8.4.1 CF_ CONT Command .....</b>	<b>19</b>
	<b>8.4.2 CF_ BRIGHT Command .....</b>	<b>19</b>
	<b>8.4.3 CF_ COLOR Command .....</b>	<b>19</b>
	<b>8.4.4 CF_ TINT Command .....</b>	<b>19</b>
	<b>8.4.5 CF_ COLMNSAV Command .....</b>	<b>20</b>
	<b>8.4.6 CF_ COLMNL D Command .....</b>	<b>20</b>
	<b>8.4.7 CF_ APCTRL Command .....</b>	<b>20</b>

8.4.8 CF_COLTEMP Command .....	20
8.4.9 CF_WBAL- Command .....	21
8.4.10 CF_OFFSET- Command .....	21
8.4.11 CF_SHARP Command .....	21
8.4.12 CF_GAMMA Command .....	22
8.4.13 CF_NZRED Command .....	22
8.4.14 CF_PROGV Command .....	22
8.4.15 CF_IMAGE Command .....	23
8.4.16 CF_IMAGEADJ Command .....	23
8.4.17 CF_ADVCOL Command .....	24
8.5 PC Control Command .....	25
8.5.1 CF_FSYNC Command .....	25
8.5.2 CF_TDOTS Command .....	25
8.5.3 CF_H-POS Command .....	25
8.5.4 CF_V-POS Command .....	26
8.5.5 CF_CLAMP Command .....	26
8.5.6 CF_DDOTS Command .....	26
8.5.7 CF_DLINE Command .....	27
8.5.8 CF_SETPCADJ Command .....	27
8.5.9 CF_ORGMODE Command .....	27
8.5.10 CF_PCSTORE Command .....	28
8.5.11 CF_PCMODEFREE Command .....	28
8.6 Input Control Command .....	29
8.6.1 CF_INPUT Command .....	29
8.6.2 CF_SOURCE Command .....	29
8.6.3 CF_INPUT1~4 Command .....	29
8.6.4 CF_SYSTEM Command .....	30
8.7 Screen Control Command .....	31
8.7.1 CF_SCREEN Command .....	31
8.7.2 CF_DZCENT Command .....	31
8.7.3 CF_KEYSTONE Command .....	32
8.7.4 CF_KEYSTONEMODE Command .....	32
8.7.5 CF_CEIL Command .....	32
8.7.6 CF_REAR Command .....	33
8.7.7 CF_VSCALE Command .....	33
8.7.8 CF_VPOS Command .....	33
8.7.9 CF_HSCALE Command .....	34
8.7.10 CF_HPOS Command .....	34
8.8 Lamp Command .....	35
8.8.1 CF_LAMPH Command .....	35

8.8.2 CF_LAMPMODE Command.....	35
8.8.3 CF_AUTOLAMPCTRL Command.....	35
8.9 Setting Command .....	36
8.9.1 CF_LANG Command.....	36
8.9.2 CF_DISP Command .....	36
8.9.3 CF_BACKGND Command .....	36
8.9.4 CF_LOGO Command .....	37
8.9.5 CF_FANSPEED Command .....	37
8.9.6 CF_RCODE Command.....	37
8.9.7 CF_RSENS Command .....	38
8.9.8 CF_P-MANE Command .....	38
8.9.9 CF_P-MANETIME Command.....	38
8.9.10 CF_ON-STA Command .....	38
8.9.11 CF_PJPINCODE Command.....	39
8.9.12 CF_FILH Command.....	39
8.9.13 CF_FILTIMER Command .....	39
8.9.14 CF_FILCTL Command .....	39
8.9.15 CF_FILSCRL Command.....	40
8.9.16 CF_TESTPAT Command.....	40
8.9.17 CF_FDEFAULT Command .....	40
8.9.18 CF_KEYDIS Command .....	40
8.9.19 CF_SHUTRCPROT Command.....	41
8.9.20 CF_SHUTKEYPROT Command .....	41
8.9.21 CF_SHUTH Command .....	41
8.10 Other Command.....	41
8.10.1 CF_SHUTTER Command.....	41
8.11 HD data wireless Command.....	42
8.11.1 CF_HDWLMODE Command .....	42
8.11.2 CF_HDWLAUTH Command.....	42
8.11.3 CF_HDWLINID Command.....	42
8.11.4 CF_HDWLFDEF Command.....	42
9. Status Read Command.....	43
9.1 Format.....	43
9.2 Transfer Example.....	43
9.3 Operation condition.....	43
9.4 Image Status Read Commands .....	44
9.4.1 CR_CONT Command .....	44
9.4.2 CR_BRIGHT Command .....	44
9.4.3 CR_COLOR Command .....	44
9.4.4 CR_TINT Command .....	44

9.4.5 CR_APCTRL Command.....	44
9.4.6 CR_COLTEMP Command.....	45
9.4.7 CR_WBAL-R Command.....	45
9.4.8 CR_WBAL-G Command.....	45
9.4.9 CR_WBAL-B Command.....	45
9.4.10 CR_OFFSET-R Command.....	45
9.4.11 CR_OFFSET-G Command.....	45
9.4.12 CR_OFFSET-B Command.....	46
9.4.13 CR_SHARP Command.....	46
9.4.14 CR_GAMMA Command.....	46
9.4.15 CR_NZRED Command.....	46
9.4.16 CR_PROGV Command.....	46
9.4.17 CR_IMAGE Command.....	47
9.4.18 CR_IMGGMD Command.....	47
9.4.19 CR_ADVCOL Command.....	47
9.5 PC Status Read Commands.....	48
9.5.1 CR_FSYNC Command.....	48
9.5.2 CR_TDOTS Command.....	48
9.5.3 CR_H-POS Command.....	48
9.5.4 CR_V-POS Command.....	48
9.5.5 CR_CLAMP Command.....	49
9.5.6 CR_DDOTS Command.....	49
9.5.7 CR_DLINE Command.....	49
9.5.8 CR_SETPCADJ Command.....	50
9.5.9 CR_ORGMODE Command.....	51
9.5.10 CR_PCSTORE Command.....	51
9.6 Video Status Read Command.....	52
9.6.1 CR_SERSYS Command.....	52
9.7 Input Read Command.....	52
9.7.1 CR_INPUT Command.....	52
9.7.2 CR_SOURCE Command.....	52
9.7.3 CR_SYSTEM Command.....	53
9.7.4 CR_SRCINP1 Command.....	54
9.7.5 CR_SRCINP2 Command.....	54
9.7.6 CR_SRCINP3 Command.....	54
9.7.7 CR_SRCINP4 Command.....	54
9.7.8 CR_HMSLOT Command.....	54
9.7.9 CR_NMSLOT1 Command.....	55
9.7.10 CR_NMSLOT2 Command.....	55
9.7.11 CR_NMSLOT3 Command.....	55

9.7.12 CR_NMSLOT4 Command .....	55
9.7.13 CR_IDSLOT1 Command .....	56
9.7.14 CR_IDSLOT2 Command .....	56
9.7.15 CR_IDSLOT3 Command .....	56
9.7.16 CR_IDSLOT4 Command .....	56
9.8 Screen Status Read Commands .....	57
9.8.1 CR_SCREEN Command .....	57
9.8.2 CR_KYSTNMODE Command .....	57
9.8.3 CR_CEIL Command .....	57
9.8.4 CR_REAR Command .....	57
9.8.5 CR_VSCALE Command .....	57
9.8.6 CR_VPOS Command .....	57
9.8.7 CR_HSCALE Command .....	58
9.8.8 CR_HPOS Command .....	58
9.9 Lamp Status Read Commands .....	59
9.9.1 CR_LAMPREPL Command .....	59
9.9.2 CR_LAMPMODE Command .....	59
9.9.3 CR_AUTOLAMPCTRL Command .....	59
9.9.4 CR_LAMPSTS Command .....	59
9.9.5 CR_INFLAMP Command .....	60
9.9.6 CR_PROJH Command .....	60
9.9.7 CR_HMLAMP Command .....	60
9.9.8 CR_LAMPH Command .....	60
9.10 Setting Status Read Commands .....	61
9.10.1 CR_BACKGND Command .....	61
9.10.2 CR_DISP Command .....	61
9.10.3 CR_LOGO Command .....	61
9.10.4 CR_LOGOLOCK Command .....	61
9.10.5 CR_RCODE Command .....	61
9.10.6 CR_RSENS Command .....	62
9.10.7 CR_LANG Command .....	62
9.10.8 CR_ON-STA Command .....	62
9.10.9 CR_P-MANE Command .....	62
9.10.10 CR_P-MANETIME Command .....	63
9.10.11 CR_FANSPEED Command .....	63
9.10.12 CR_KEYDIS Command .....	63
9.10.13 CR_SHUTRCPROT Command .....	63
9.10.14 CR_SHUTKEYPROT Command .....	63
9.10.15 CR_SHUTH Command .....	64
9.10.16 CR_SECURITY Command .....	64

9.10.17	<b>CR_PJLOCKNOW Command</b> .....	64
9.10.18	<b>CR_PJLOCMENU Command</b> .....	64
9.10.19	<b>CR_FILH Command</b> .....	64
9.10.20	<b>CR_FILCOND Command</b> .....	65
9.10.21	<b>CR_FILREPL Command</b> .....	65
9.10.22	<b>CR_FILTIMER Command</b> .....	65
9.10.23	<b>CR_FILREMAIN Command</b> .....	65
9.10.24	<b>CR_TESTPAT Command</b> .....	66
9.11	<b>Other Status Read Commands</b> .....	67
9.11.1	<b>CR_STATUS Command</b> .....	67
9.11.2	<b>CR_SIGNAL Command</b> .....	67
9.11.3	<b>CR_VMUTE Command</b> .....	67
9.11.4	<b>CR_FREEZE Command</b> .....	67
9.11.5	<b>CR_P-TIMER Command</b> .....	68
9.11.6	<b>CR_TEMPWARN Command</b> .....	68
9.11.7	<b>CR_TEMPFAIL Command</b> .....	69
9.11.8	<b>CR_SERIALNO Command</b> .....	69
9.11.9	<b>CR_SHUTCOND Command</b> .....	69
9.12	<b>HD-wireless Read Commands</b> .....	70
9.12.1	<b>CR_HDWLMODE Command</b> .....	70
9.12.2	<b>CR_HDWLAUTH Command</b> .....	70
9.12.3	<b>CR_HDWLINID Command</b> .....	70
9.12.4	<b>CR_HDWLRECEPLV Command</b> .....	70
10.	<b>Command with Address Specification</b> .....	71
10.1.	<b>Overview</b> .....	71
10.2.	<b>Functional Execution Command with address</b> .....	71
10.2.1.	<b>Format</b> .....	71
10.2.2.	<b>When the command pipelining is needed</b> .....	72
10.3.	<b>Status Read Command with Address</b> .....	72
10.3.1.	<b>Format</b> .....	72

## 1. Overview

- This Functional Specification defines communication with Network board for PLC-XF1000.
- Commands are designed to communicate with Network board, but most commands are also available to remote-control a projector through RS-232C from a computer. Therefore, commands are defined as Expand Serial Commands.
- The operation by some commands depends on Optional Board installed in Input Slot of the projector.
- This document assumes that Option Boards are installed.

## 2. Serial Interface Specification

### 2.1 Transfer Specification

Items	Specification
Synchronous System	Asynchronous
Transmission Speed	9600 / 19200
Data Length	8 bit
Parity	N/A
Stop Bit	1
Flow Control	N/A

1) Transmission Speed: initial setting value is 19200

2) Transmission Speed can be changed in Service Mode

### 2.2 Connection

Dedicated serial cables that come with a projector must be used for the connection between a computer and the projector.

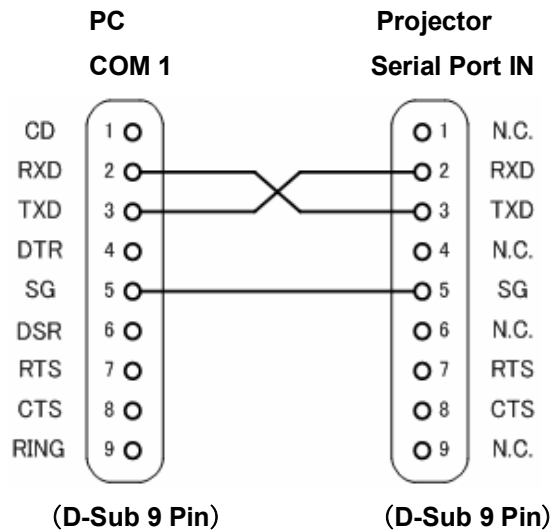

Connect COM port of the computer to SERIAL PORT IN of the projector.

COM Port (COM1 or COM2) of a computer is specified by control software of the computer.

### 3. Notes for communication

- Expand Serial Command is defined as a single command per line that starts with “C” and ends with carriage return (0x0D).
- When a projector receives carriage return (0x0D), it starts decoding.
- There are two types of commands as below:
  - Example of Functional Execution Command: “CF\_BRIGHT\_032” [CR]
  - Example of Status Read Command: “CR\_BRIGHT” [CR]
  - Note) “\_” indicates a space
- It clears the information of buffer in the following cases:
  - when the projector receives LF (0x0A) or EOF (0x1A).
  - when it takes more than one second to receive a single command  
(Until receiving the carriage return after the reception of the first data)
- The projector processes the command and returns the response within a few ms to 8000 ms after the reception of the command. When several commands are sent in succession, do not send another command unless the response to the previous command has been returned. Need to confirm that the processing of the current command has been completed and returned the response before sending another command.

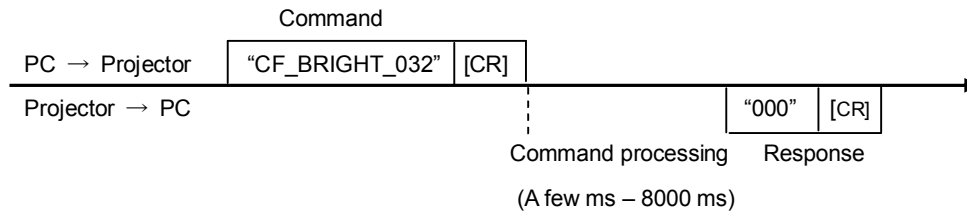

Note) when the computer sends another command before the previous response has been returned, the projector may not operate properly.

Note) when the current command processing has not completed, another command process can not be accepted by the projector

- Normally it is less than 1000ms for the completion of receiving a command and returning the response, but it takes more than 1000ms for some Functional Execution Commands as listed below:

Command	Item
CF_IMAGE	Select Image Mode
CF_INPUT	Select Input
CF_SCREEN	Select Screen Size
CF_SYSTEM	Select System
CF_INPUT1	Select Input 1 and Signal (concurrent execution)
CF_INPUT2	Select Input 2 and Signal (concurrent execution)
CF_INPUT3	Select Input 3 and Signal (concurrent execution)
CF_INPUT4	Select Input 4 and Signal (concurrent execution)
CF_IMAGEADJ	Reset/Store for Image Adjustment

- It takes about 8 seconds for internal initialization after plugging in AC power. During this time it cannot process commands. Do not issue any command.

#### 4. Notation

- Data from a controller to a projector is represented as COMMAND, and data from a projector to a controller in response to the incoming command is represented as RESPONSE.
- [CR]: Carriage Return Code  
The command ends with carriage return code.  
The response also ends with carriage return code.
- \_: Space Code  
All space code is indicated by (\_).
- %1: Parameter included in command  
When there is more than one parameter, they are represented as %2, %3...

## 5. Functional Execution Command Table

### 5.1 Image Command Table

Execute command	Item
CF_CONT_%1[CR]	Set value of Contrast
CF_BRIGHT_%1[CR]	Set value of Brightness
CF_COLOR_%1[CR]	Set value of Color
CF_TINT_%1[CR]	Set value of Tint
CF_COLMNSAV_%1[CR]	Set area to store current values of Color Management
CF_COLMNLD_%1[CR]	Set area to load values of Color Management
CF_APCTRL_%1[CR]	Set level of Auto Picture Control
CF_COLTEMP_%1[CR]	Set level of Color Temperature
CF_WBAL-R_%1[CR]	Set Red value of White Balance
CF_WBAL-G_%1[CR]	Set Green value of White Balance
CF_WBAL-B_%1[CR]	Set Blue value of White Balance
CF_OFFSET-R_%1 [CR]	Set Red value of Offset
CF_OFFSET-G_%1 [CR]	Set Green value of Offset
CF_OFFSET-B_%1 [CR]	Set Blue value of Offset
CF_SHARP_%1[CR]	Set value of Sharpness
CF_GAMMA_%1[CR]	Set value of Gamma
CF_NZRED_%1[CR]	Set ON/OFF of Noise reduction
CF_PROGV_%1[CR]	Set mode of Progressive scan
CF_IMAGE_%1[CR]	Set Image mode
CF_IMAGEADJ_%1[CR]	Set Store/Reset of values in Image Adjustment
CF_ADVCOL_%1[CR]	Set mode of Advanced color setting

### 5.2 PC Control Command Table

Execute command	Item
CF_FSYNC_%1[CR]	Set value of Fine Sync
CF_TDOTS_%1[CR]	Set value of Total Dots
CF_CLAMP_%1[CR]	Set value of Clamp
CF_H-POS_%1[CR]	Set value of Horizontal Position
CF_V-POS_%1[CR]	Set value of Vertical Position
CF_DDOTS_%1[CR]	Set value of Display Dots
CF_DLINE_%1[CR]	Set value of Display Line
CF_SETPCADJ_%1[CR]	Apply values set in PC Adjust menu to screen image
CF_ORGMODE_%1[CR]	Specify the original signal for the selected PC mode
CF_PCSTORE_%1[CR]	Store current setting values in PC Adjust menu to Mode %1
CF_PCMODEFREE_%1 [CR]	Delete the values registered in Mode %1 and return it to Free status.

### 5.3 Input Control Command Table

Execute command	Item
CF_INPUT_%1[CR]	Select Input
CF_SOURCE_%1[CR]	Select Source of selected Input
CF_INPUT1_%1[CR]	Select Input1 and also set input source to %1
CF_INPUT2_%1[CR]	Select Input2 and also set input source to %1
CF_INPUT3_%1[CR]	Select Input3 and also set input source to %1
CF_INPUT4_%1[CR]	Select Input4 and also set input source to %1
CF_SYSTEM_%1[CR]	Select System in Video input mode

### 5.4 Screen Command Table

Execute command	Item
CF_SCREEN_%1[CR]	Select Screen size
CF_DZCENT_%1[CR]	Cancel Digital Zoom mode
CF_KEYSTONE_%1[CR]	Set Keystone correction
CF_KYSTNMODE_%1 [CR]	Set Keystone store mode
CF_CEIL_%1[CR]	Set ON/OFF of Ceiling
CF_REAR_%1[CR]	Set ON/OFF of Rear
CF_VSCALE_%1[CR]	Set V Scale
CF_VPOS_%1[CR]	Set V Position
CF_HSCALE_%1[CR]	Set H Scale
CF_HPOS_%1[CR]	Set H Position

### 5.5 Lamp Command Table

Execute command	Item
CF_LAMPH_%1[CR]	Reset total running time for each lamp
CF_LAMPMODE_%1[CR]	Select lamp mode (Full/Half)
CF_AUTOLAMPCTRL_%1[CR]	Switch dimmer function levels of Normal/Auto/Eco

## 5.6 Setting Command Table

Execute command	Item
CF_LANG_%1[CR]	Select language for OSD
CF_DISP_%1[CR]	Set ON/OFF of On Screen Display
CF_BACKGND_%1[CR]	Select screen for no signal
CF_LOGO_%1[CR]	Set ON/OFF of Logo
CF_FANSPEED_%1[CR]	Select Fan Speed
CF_RCODE_%1[CR]	Select Remote Control Code
CF_RSENS_%1[CR]	Select location of infrared remote receiver of remote control
CF_P-MANE_%1[CR]	Set ON/OFF of Power Management
CF_P-MANETIME_%1[CR]	Set time of Power Management
CF_ON-STA_%1[CR]	Set ON/OFF of Power ON Start
CF_PJPINCODE_%1[CR]	Enter PJ PIN code to cancel PJ lock
CF_FILH_%1[CR]	Reset Filter used time
CF_FILTIMER_%1[CR]	Set time to display Filter cleaning / replacement warning on screen
CF_FILCTL_%1[CR]	Execute operation of scroll of filter
CF_FILSCRL_%1[CR]	Reset Filter scroll counter
CF_TESTPAT_%1[CR]	Set Test pattern display function
CF_KEYDIS_%1[CR]	Set limitation of RC/KEY control
CF_FDEFAULT_%1[CR]	Return the settings to Factory Default status
CF_SHUTRCPROT_%1[CR]	Set valid / invalid of RC use on Shutter control function
CF_SHUTKEYPROT_%1[CR]	Set valid / invalid use of key on the top panel on Shutter control function
CF_SHUTH_%1[CR]	Set time of operating shutter management function

## 5.7 Other Command Table

Execute command	Item
CF_SHUTTER_%1[CR]	Control OPEN / CLOSE of Shutter

## 5.8 HD-data-wireless Command Table

Execute command	Item
CF_HDWLMODE_%1[CR]	Set communication mode with a radio transmitter
CF_HDWLAUTH_%1[CR]	Perform/ cancel the authentication between projector and radio transmitter
CF_HDWLINID_%1[CR]	Set the Input ID of the transmitters
CF_HDWLFDEF_%1[CR]	Return the settings to Factory Default status of HD data wireless setting

## 6. Status Read Command Table

### 6.1 Image Status Read Command Table

Status read command	Item
CR_CONT [CR]	Get value of Contrast
CR_BRIGHT [CR]	Get value of Brightness
CR_COLOR [CR]	Get value of Color
CR_TINT [CR]	Get value of Tint
CR_APCTRL	Get setting status of Auto Picture Control
CR_COLTEMP	Get value of Color temperature
CR_WBAL-R [CR]	Get Red value of White Balance
CR_WBAL-G [CR]	Get Green value of White Balance
CR_WBAL-B [CR]	Get Blue value of White Balance
CR_OFFSET-R [CR]	Get Offset Red
CR_OFFSET-G [CR]	Get Offset Green
CR_OFFSET-B [CR]	Get Offset Blue
CR_SHARP [CR]	Get value of Sharpness
CR_GAMMA [CR]	Get value of Gamma
CR_NZRED [CR]	Get setting status of Noise reduction
CR_PROGV [CR]	Get setting status of Progressive scan
CR_IMAGE [CR]	Get Selected Image status
CR_IMGGMD [CR]	Get setting value of Image Gamma
CR_ADVCOL [CR]	Get setting status of Advanced color

### 6.2 PC Status Read Command Table

Status read command	Item
CR_FSYNC [CR]	Get setting value of Fine Sync
CR_TDOTS [CR]	Get setting value of Total Dots
CR_CLAMP [CR]	Get setting value of Clamp
CR_H-POS [CR]	Get setting value of Horizontal Position
CR_V-POS [CR]	Get setting value of Vertical Position
CR_DDOTS [CR]	Get setting value of Display Dots
CR_DLINE [CR]	Get setting value of Display Line
CR_SETPCADJ [CR]	Get currently displayed signal
CR_ORGMODE [CR]	Get the original signal of the mode adjusted in PC Adj.
CR_PCSTORE [CR]	Get Free or Stored status for PC Adj. Mode 1-10

### 6.3 Video Status Read Command Table

Status read command	Item
CR_SERSYS [CR]	Get currently selected signal. In Auto mode, it returns a result by Auto detection.

#### 6.4 Input Status Read Command Table

Status read command	Item
CR_INPUT [CR]	Get selected Input
CR_SOURCE [CR]	Get selected Source
CR_SYSTEM [CR]	Get selected System in Video Input mode
CR_SRCINP1 [CR]	Get selected source for Input 1
CR_SRCINP2 [CR]	Get selected source for Input 2
CR_SRCINP3 [CR]	Get selected source for Input 3
CR_SRCINP4 [CR]	Get selected source for Input 4
CR_HMSLOT [CR]	Get the total number of Slots
CR_NMSLOT1 [CR]	Get a card name inserted to Slot 1
CR_NMSLOT2 [CR]	Get a card name inserted to Slott2
CR_NMSLOT3 [CR]	Get a card name inserted to Slot 3
CR_NMSLOT4 [CR]	Get a card name inserted to Slot 4
CR_IDSLOT1 [CR]	Get ID information of Slot 1
CR_IDSLOT2 [CR]	Get ID information of Slot 2
CR_IDSLOT3 [CR]	Get ID information of Slot 3
CR_IDSLOT4 [CR]	Get ID information of Slot 4

#### 6.5 Screen Status Read Command Table

Status read command	Item
CR_SCREEN [CR]	Get selected screen size
CR_KYSTNMODE[CR]	Get selected Keystone store mode
CR_CEIL[CR]	Get selected ON/OFF of Ceiling
CR_REAR[CR]	Get selected ON/OFF of Rear
CR_VSCALE[CR]	Get setting status of V Scale
CR_VPOS[CR]	Get setting status of V Position
CR_HSCALE[CR]	Get setting status of H Scale
CR_HPOS[CR]	Get setting status of H Position

#### 6.6 Lamp Status Read Command Table

Status read command	Item
CR_LAMPREPL [CR]	Get information on Lamp replacement time
CR_LAMPMODE [CR]	Get selected Lamp mode
CR_AUTOLAMPCONTROL[CR]	Get setting status of dimmer function level.
CR_LAMPSTS [CR]	Get Lamp lighting status
CR_INFLAMP [CR]	Get Lamp switching status
CR_PROJH [CR]	Get the projector total running time
CR_HMLAMP [CR]	Get the total number of lamps
CR_LAMPH [CR]	Get information of actual Lamp running time

**6.7 Setting Status Read Command Table**

Status read command	Item
CR_LANG [CR]	Get selected language
CR_DISP [CR]	Get setting status of Display
CR_BACKGND [CR]	Get setting status of Screen for no signal
CR_LOGO [CR]	Get setting status of Logo
CR_LOGOLOCK [CR]	Get setting status of Logo Lock
CR_FANSPEED [CR]	Get selected Fan Control Speed
CR_RCODE [CR]	Get selected Remote Control Code
CR_RSENS [CR]	Get selected location of infrared remote receiver of remote control
CR_P-MANE [CR]	Get setting status of Power management
CR_P-MANETIME [CR]	Get setting time for Power Management
CR_ON-STA [CR]	Get setting status of ON Start
CR_SECURITY [CR]	Get setting status of Security
CR_PJLOCKNOW [CR]	Get setting status of current PJ Lock
CR_PJLOCKMENU [CR]	Get PJ Lock setting status on the menu
CR_FILH[CR]	Get Filter used time
CR_FILCOND[CR]	Get status of filter clog
CR_FILREPL[CR]	Get status of Filter cleaning / replacement time
CR_FILTIMER[CR]	Get time to display Filter cleaning / replacement warning on screen
CR_FILREMAIN[CR]	Get remaining number of usable Filter scroll
CR_TESTPAT[CR]	Get setting status of Test pattern
CR_KEYDIS [CR]	Get setting status of RC/KEY control limitation
CR_SHUTRCPROT[CR]	Get remote controller disability status of the shutter
CR_SHUTKEYPROT[CR]	Get Key controller disability state of the shutter
CR_SHUTH[CR]	Get time setting to begin the shutter management

**6.8 Other Status Read Command Table**

Status read command	Item
CR_STATUS [CR]	Get operation state of the projector
CR_SIGNAL [CR]	Get status of signal existence
CR_VMUTE [CR]	Get setting status of Video mute
CR_FREEZE [CR]	Get setting status of Freeze
CR_PTIMER [CR]	Get operating status of P-Timer
CR_TEMPWARN [CR]	Get temperature status whether it is close to abnormal level or not
CR_TEMPFAIL [CR]	Get temperature in abnormal temperature status
CR_SERIALNO [CR]	Get value of Serial number
CR_SHUTCOND [CR]	Get setting status of Shutter

**6.9 HD data wireless Status Read Command Table**

Status read command	Item
CR_HDWLMODE [CR]	Get communication mode with a radio transmitter.
CR_HDWLAUTH [CR]	Get status of the authentication between projector and radio transmitter
CR_HDWLINID [CR]	Get the ID of the transmitter
CR_HDWLRECEPLV [CR]	Get status of the reception level of a radio beam

**7. Error Code Table**

<b>Error Code</b>	<b>Contents</b>
?	-When the received data cannot be decoded -Parameter designation error (wrong digit number, including invalid value, etc.)
000	Normal reception (This is "Not" error)
101	Specified function is not available in the selected mode
102	Specified value is out of range (Not reflected)
103	Command mismatched to Hardware (the command is for Optional function which is not implemented)
201	Incremented or decremented value or values are beyond upper or lower limits.
301	Not executable due to screen capturing in process. Prompting reissue of the command after a while.
402	Not executable due to PIN code in operation. Prompting reissue of the command after a while.

## 8. Functional Execution Command

### 8.1 Format

1) PC issues a command in the format below:

**Pattern1:** "CF\_ Command" [CR]

**Pattern2:** "CF\_ Command\_" %1 [CR]

CF\_: Header

Command: String

%1: Parameter (String)

\_ : Space (To separate Command and Parameter)

2) The projector decodes the received command and when it gets ready to receive another command, it returns the response.

**"000" [CR]:** (0x06, 0x0D) When receiving Functional Execution Command

**"nnn" [CR]:** Except "000", when it cannot execute commands for any specific reason.

For detail, refer to [7. Error Code Table]

**"?" [CR]:** When the received data cannot be decoded

### 8.2 Transfer Example

When setting projector's total dots to 1344 by Expand Command.

PC → PJ: "CF\_TDOTS\_1344" [CR]

PC ← PJ: "000" [CR] ----- Acceptable

### 8.3 Operation Requirements

When the projector status is in the status below, Functional Execution Commands are limited  
(Status Read Commands are available in following status)

Projector Status	Available Functional Execution Command
In Standby Mode	C00: POWER ON
Count Down in process	C00: POWER ON (Countdown is terminated)
Cooling Down in process	NONE (No Execution)
Cooling Down in process due to abnormal temperature	NONE (No Execution)
In Abnormal Temperature	NONE (No Execution)
Power Failure (60 seconds after Power failed)	NONE (No Execution)
Power Saving Cooling Down in process	NONE (No Execution)
In Power Saving status	C00: POWER ON C01: POWER OFF

Note) An appropriate error code is returned when the projector receives other command in the above status.

## 8.4 Image Command

### 8.4.1 CF\_CONT Command

Command	"CF_CONT_%1" [CR]	
%1	"000-063"----- Directly specify setting value of Contrast "UP"----- Increment setting value of Contrast by 1 "DN"----- Decrement setting value of Contrast by 1	
Details	Set user controlled value of Contrast. (Available only in the normal Power ON status) The value set by this command is not stored in the projector. Therefore, when the power is turned to ALL OFF status, the value returns to the original setting. (It is stored in Suspend mode.)	
Response	Acceptable	"000" [CR]
	Unacceptable	"Error Code" [CR]

### 8.4.2 CF\_BRIGHT Command

Command	"CF_BRIGHT_%1" [CR]	
%1	"000-063" ----- Directly specify setting value of Brightness "UP" ----- Increment setting value of Brightness by 1 "DN" ----- Decrement setting value of Brightness by 1	
Details	Set user controlled value of Brightness. (Available only in the normal Power ON status) The value set by this command is not stored in the projector's memory. Therefore, when the power is turned to ALL OFF status, the value returns to the original setting. (It is stored in Suspend mode.)	
Response	Acceptable	"000" [CR]
	Unacceptable	"Error Code" [CR]

### 8.4.3 CF\_COLOR Command

Command	"CF_COLOR_%1" [CR]	
%1	"000-063"----- Directly specify setting value of Color "UP"----- Increment setting value of Color by 1 "DN"----- Decrement setting value of Color by 1	
Details	Set user controlled value of Color. (Available only in the normal Power ON status) The value set by this command is not stored in the projector's memory. Therefore, when the power is turned to ALL OFF status, the value returns to the original setting. (It is stored in Suspend mode.)	
Response	Acceptable	"000" [CR]
	Unacceptable	"Error Code" [CR]

### 8.4.4 CF\_TINT Command

Command	"CF_TINT_%1" [CR]	
%1	"000-063"----- Directly specify setting value of Tint "UP"----- Increment setting value of Tint by 1 "DN"----- Decrement setting value of Tint by 1	
Details	Set user controlled value of Tint (Available only in the normal Power ON status) The value set by this command is not stored in the projector's memory. Therefore, when the power is turned to ALL OFF status, the value returns to the original setting. (It is stored in Suspend mode.)	
Response	Acceptable	"000" [CR]
	Unacceptable	"Error Code" [CR]

### 8.4.5 CF\_COLMNSAV Command

Command	"CF_COLMNSAV_%1" [CR]	
%1	"000 – 009" ----- Specify the area to store	
Details	Store current setting status of Color Management to the area specified in %1. (Available only in the normal Power ON status)	
Response	Acceptable	"000" [CR]
	Unacceptable	"Error Code" [CR]

### 8.4.6 CF\_COLMNLD Command

Command	"CF_COLMNLD_%1" [CR]	
%1	"000 – 009" ----- Specify the area to store	
Details	Retrieve Color Management setting status from the area specified in %1. (Available only in the normal Power ON status)	
Response	Acceptable	"000" [CR]
	Unacceptable	"Error Code" [CR]

### 8.4.7 CF\_APCTRL Command

Command	"CF_APCTRL_%1" [CR]	
%1	"L1" ----- Set Auto Picture Control to Level 1. "L2" ----- Set Auto Picture Control to Level 2. "OFF" ----- Set Auto Picture Control OFF. "UP" ----- Switch setting forward direction (OFF→L1→L2→OFF) "DN" ----- Switch setting backward direction (OFF→L2→L1→OFF)	
Details	Set Auto Picture Control (Available only in the normal Power ON status) The value set by this command is not stored in the projector's memory. Therefore, when the power is turned to ALL OFF status, the value returns to the original setting. (It is stored in Suspend mode.)	
Response	Acceptable	"000" [CR]
	Unacceptable	"Error Code" [CR]

### 8.4.8 CF\_COLTEMP Command

Command	"CF_COLTEMP_%1" [CR]	
%1	"000" – "003"	
Details	Set Color Temperature (Available only in the normal Power ON status) The value set by this command is not stored in the projector's memory. Therefore, when the power is turned to ALL OFF status, the value returns to the original setting. (It is stored in Suspend mode.)	
Response	Acceptable	"000" [CR]
	Unacceptable	"Error Code" [CR]

### 8.4.9 CF\_WBAL- Command

Command	"CF_WBAL-%1_%2" [CR]	
%1	"R" ----- RED "G" ----- GREEN "B" ----- BLUE	
%2	"000-063"----- Directly specify value of Color selected in %1 of White Balance. "UP"----- Increment setting value of Color specified in %1 of White Balance by 1 "DN"----- Decrement setting value of Color specified in %1 of White Balance by 1	
Details	Set value of Color specified in %1 of White Balance (Available only in the normal Power ON status) The value set by this command is not stored in the projector's memory. Therefore, when the power is turned to ALL OFF status, the value returns to the original setting. (It is stored in Suspend mode.)	
Response	Acceptable	"000" [CR]
	Unacceptable	"Error Code" [CR]

### 8.4.10 CF\_OFFSET- Command

Command	"CF_OFFSET-%1_%2" [CR]	
%1	"R" ----- RED "G" ----- GREEN "B" ----- BLUE	
%2	"000-063"----- Directly specify value of Color selected in %1 of Offset. "UP"----- Increment setting value of Color specified in %1 of Offset by 1 "DN"----- Decrement setting value of Color specified in %1 of Offset by 1	
Details	Set value of Color specified in %1 of Offset (Available only in the normal Power ON status) The value set by this command will not be stored in the projector's memory. Therefore, when the power is turned to ALL OFF status, the value returns to the original setting. (It is stored in Suspend mode.)	
Response	Acceptable	"000" [CR]
	Unacceptable	"Error Code"[CR]

### 8.4.11 CF\_SHARP Command

Command	"CF_SHARP_%1" [CR]	
%1	"000-031" ----- Directly specify setting value of Sharpness. "UP"----- Increment setting value of Sharpness by 1 "DN"----- Decrement setting value of Sharpness by 1	
Details	Set user controlled value of Sharpness. (Available only in the normal Power ON status) The value set by this command is not stored in the projector's memory. Therefore, when the power is turned to ALL OFF status, the value returns to the original setting. (It is stored in Suspend mode.)	
Response	Acceptable	"000" [CR]
	Unacceptable	"Error Code" [CR]

### 8.4.12 CF\_GAMMA Command

Command	"CF_GAMMA_%1" [CR]	
%1	"000-015" ----- Directly specify setting value of Gamma "UP"----- Increment setting value of Gamma by 1 "DN"----- Decrement setting value of Gamma by 1	
Details	Set user controlled value of Gamma. (Available only in the normal Power ON status) The value set by this command is not stored in the projector's memory. Therefore, when the power is turned to ALL OFF status, the value returns to the original setting. (It is stored in Suspend mode.)	
Response	Acceptable	"000" [CR]
	Unacceptable	"Error Code" [CR]

### 8.4.13 CF\_NZRED Command

Command	"CF_NZRED_%1" [CR]	
%1	"ON" ----- Set Noise Reduction to ON "OFF" ----- Set Noise Reduction to OFF	
Details	Set or Cancel Noise Reduction. (Available only in the normal Power ON status) The value set by this command is not stored in the projector's memory. Therefore, when the power is turned to ALL OFF status, the value returns to the original setting. (It is stored in Suspend mode.)	
Response	Acceptable	"000" [CR]
	Unacceptable	"Error Code" [CR]

### 8.4.14 CF\_PROGV Command

Command	"CF_PROGV_%1" [CR]	
%1	"ON" ----- Set Progressive scan to ON "FILM" ----- Set Progressive scan to Film mode "OFF" ----- Set Progressive scan to OFF	
Details	Set or Cancel Progressive scan. (Valid only when it is in the normal Power ON status.) The value set by this command is not stored in the projector's memory. Therefore, when the power is turned to ALL OFF status, the value returns to the original setting. (It is stored in Suspend mode.)	
Response	Acceptable	"000" [CR]
	Unacceptable	"Error Code" [CR]

### 8.4.15 CF\_IMAGE Command

Command	"CF_IMAGE_%1" [CR]	
%1	<p>"STAND" ----- Standard (Image adjustment value is set to factory default)                  "REAL" ----- Real (Fixed value to display graphic image with natural tone)                  "CINEMA" ----- Cinema (Fixed value to focus on tone reproduction for movie)                  "CUSTOM1" ----- Image1 (values adjusted and stored by user)                  "CUSTOM2" ----- Image2 (values adjusted and stored by user)                  "CUSTOM3" ----- Image3 (values adjusted and stored by user)                  "CUSTOM4" ----- Image4 (values adjusted and stored by user)                  "CUSTOM5" ----- Image5 (values adjusted and stored by user)                  "CUSTOM6" ----- Image6 (values adjusted and stored by user)                  "CUSTOM7" ----- Image7 (values adjusted and stored by user)                  "CUSTOM8" ----- Image8 (values adjusted and stored by user)                  "CUSTOM9" ----- Image9 (values adjusted and stored by user)                  "CUSTOM10" ----- Image10 (values adjusted and stored by user)</p>	
Details	<p>Select Image mode. (Valid only when it is in the normal Power ON status.)                  Parameter "CUSTOM1" to "CUSTOM10" corresponds to "Image1" to "Image10" displayed in projector OSD menu on selecting Image.                  The value set by this command is stored in EEPROM so that the setting can remain effective even after the power is turned to ALL OFF status.</p>	
Response	Acceptable	"000" [CR]
	Unacceptable	"Error Code" [CR]

### 8.4.16 CF\_IMAGEADJ Command

Command	"CF_IMAGEADJ_%1" [CR]	
%1	<p>"RST"----- Reset adjusted value for the Image                  "STR1"---- Store current adjusted value to Image 1                  "STR2"---- Store current adjusted value to Image 2                  "STR3"---- Store current adjusted value to Image 3                  "STR4"---- Store current adjusted value to Image 4                  "STR5"---- Store current adjusted value to Image 5                  "STR6"---- Store current adjusted value to Image 6                  "STR7"---- Store current adjusted value to Image 7                  "STR8"---- Store current adjusted value to Image 8                  "STR9"---- Store current adjusted value to Image 9                  "STR10"--- Store current adjusted value to Image 10</p>	
Details	<p>Reset or Store adjusted value for Image. (Available only in the normal Power ON status)                  "STR1"- "STR10" corresponds to "Image1"- "Image10" displayed in projector OSD menu on selecting "Store" for adjusted value of Image. The setting value set in "Image1" to "Image10" is stored and can be retrieved when turning on the projector again after the power is turned to ALL OFF status.</p>	
Response	Acceptable	"000" [CR]
	Unacceptable	"Error Code" [CR]

### 8.4.17 CF\_ADVCOL Command

Command	"CF_ADVCOL_%1" [CR]	
%1	"AUTO" ----- Set Advanced color to Auto "OFF" ----- Set Advanced color OFF. " UP" ----- Switch setting forward direction (OFF→Auto→OFF→Auto) " DN" ----- Switch setting backward direction (OFF→Auto→OFF→Auto) *"UP" and "DN" are exactly same operation.	
Details	Set Advanced color mode (Available only in the normal Power ON status) The value set by this command is not stored in the projector's memory. Therefore, when the power is turned to ALL OFF status, the value returns to the original setting. (It is stored in Suspend mode.)	
Response	Acceptable	"000" [CR]
	Unacceptable	"Error Code" [CR]

## 8.5 PC Control Command

### 8.5.1 CF\_FSYNC Command

Command	"CF_FSYNC_%1" [CR]	
%1	"0000-0031" ----- Directly specify setting value of Fine Sync "UP" ----- Increment setting value of Fine Sync by 1 "DN" ----- Decrement setting value of Fine Sync by 1	
Details	Set value of Fine Sync in PC signal (Available only in the normal Power ON status) The value set by this command is not stored in the projector's memory. Therefore, when the power is turned to ALL OFF status, the value returns to the original setting. (It is stored in Suspend mode.)	
Response	Acceptable	"000" [CR]
	Unacceptable	"101" [CR] --- When input is Video signal --- When input is no signal

### 8.5.2 CF\_TDOTS Command

Command	"CF_TDOTS_%1" [CR]	
%1	"mmmm – nnnn" ----- Directly specify setting value of Total Dots "mmmm" indicates minimum value, which is current (Display Area H + Position H) value "nnnn" indicates maximum value, that dot clock does not exceed more than 140MHz. "UP" ----- Increment setting value of Total Dots by 1 "DN" ----- Decrement setting value of Total Dots by 1	
Details	Set value of Total Dots in PC signal (Available only in the normal Power ON status) The value set by this command is not stored in the projector's memory. Therefore, when the power is turned to ALL OFF status, the value returns to the original setting. (It is stored in Suspend mode.)	
Response	Acceptable	"000" [CR]
	Unacceptable	"101" [CR] --- When input is Video signal --- When input is no signal

### 8.5.3 CF\_H-POS Command

Command	"CF_H-POS_%1" [CR]	
%1	"0000-nnnn" ----- Directly specify setting value of Horizontal Position "nnnn" indicates maximum value, which is current value of (Total Dots – Display Area H) "UP" ----- Increment setting value of Horizontal Position by 1 "DN" ----- Decrement setting value of Horizontal Position by 1	
Details	Set value of Horizontal Position in PC signal (Available only in the normal Power ON status) The value set by this command is not stored in the projector's memory. Therefore, when the power is turned to ALL OFF status, the value returns to the original setting. (It is stored in Suspend mode.)	
Response	Acceptable	"000" [CR]
	Unacceptable	"101" [CR] --- When input is Video signal --- When input is no signal

### 8.5.4 CF\_V-POS Command

Command	"CF_V-POS_%1" [CR]	
%1	"0000-nnnn" ----- Directly specify setting value of Vertical Position "nnnn" indicates maximum value, which is current (Total Line – Display Area V) value "UP" ----- Increment setting value of Vertical Position by 1 "DN" ----- Decrement setting value of Vertical Position by 1	
Details	Set Vertical Position value in PC signal (Available only in the normal Power ON status) The value set by this command is not stored in the projector's memory. Therefore, when the power is turned to ALL OFF status, the value returns to the original setting. (It is stored in Suspend mode.)	
Response	Acceptable	"000" [CR]
	Unacceptable	"101" [CR] --- When input is Video signal --- When input is no signal

### 8.5.5 CF\_CLAMP Command

Command	"CF_CLAMP_%1" [CR]	
%1	"0000-4095" ----- Directly specify setting value of Clamp "UP" ----- Increment setting value of Clamp by 1 "DN" ----- Decrement setting value of Clamp by 1	
Details	Set Clamp value in PC signal. (Available only in the normal Power ON status) The value set by this command will not be stored in the projector's memory. Therefore, when the power is turned to ALL OFF status, the value returns to the original setting. (It is stored in Suspend mode.)	
Response	Acceptable	"000" [CR]
	Unacceptable	"101" [CR] --- When input is Video signal --- When input is no signal

### 8.5.6 CF\_DDOTS Command

Command	"CF_DDOTS_%1" [CR]	
%1	"0256-nnnn" ----- Directly specify setting value of Display Dots "nnnn" indicates maximum value, which is current value of (Total Dots - Position H). In this projector, the value should be "even number" and if "odd number" is specified, it adds 1 to make the value even number. "UP" ----- Increment setting value of Display Dots by 2 "DN" ----- Decrement setting value of Display Dots by 2	
Details	Set Display Dots value in PC signal. (Available only in the normal Power ON status) The value set by this command is not stored in the projector's memory. Therefore, when the power is turned to ALL OFF status, the value returns to the original setting. (It is stored in Suspend mode.)	
Response	Acceptable	"000" [CR]
	Unacceptable	"101" [CR] --- When input is Video signal --- When input is no signal

### 8.5.7 CF\_DLINE Command

Command	"CF_DLINE_%1" [CR]	
%1	"0100-nnnn" ----- Directly specify setting value of Display Line "nnnn" indicates maximum value, which is current value of (Total Line - Position V). "UP" ----- Increment setting value of Display Line by 1 "DN" ----- Decrement setting value of Display line by 1	
Details	Set setting value of Display Line in PC signal (Available only in the normal Power ON status) The value set by this command is not being stored in the projector's memory. Therefore, when the power is turned to ALL OFF status, the value returns to the original setting. (It is stored in Suspend mode.)	
Response	Acceptable	"000" [CR]
	Unacceptable	"101" [CR] --- When input is Video signal --- When input is no signal

### 8.5.8 CF\_SETPCADJ Command

Command	"CF_SETPCADJ_%1" [CR]	
%1	"XGA1", "HDTV1080", "MODE1" .....Etc. "EXT11"~"EXT60"	
Detail	Note1) When "XGA", "HDTV1080", "MODE1" is specified in %1, the command is not executed. Note2) When "EXTn-EXTnn" (nn represents number) is specified in %1, "EXT" is displayed in "SYSTEM" menu (only when Network board is provided).	
Response	Acceptable	"000" [CR]
	Unacceptable	"101" [CR] --- When input is Video signal

### 8.5.9 CF\_ORGMODE Command

Command	"CF_ORGMODE_%1" [CR]	
%1	When input signal is PC Analog; "VGA1" ----- Specify VGA1 "VGA2" ----- Specify VGA2 : "XGA1" ----- Specify XGA1 : "WXGA3" ----- Specify WXGA3 "1080I60" ----- Specify 1080i60 "1080I50" ----- Specify 1080i50 "1035I" ----- Specify 1035i "720P60" ----- Specify 720p60 "720P50" ----- Specify 720p50 "575P" ----- Specify 575p "480P" ----- Specify 480p "575I" ----- Specify 575i "480I" ----- Specify 480i "1080PSF/24" ----- Specify 1080psf/24 "1080PSF/25" ----- Specify 1080psf/25 "1080PSF/30" ----- Specify 1080psf/30 * When input signal is not PC Analog, error code "101" is returned.	
Details	After "EXT n" is set by PC control command such as CF_FSYNC/CF_TDOTS and CF_SETPCADJ command, specify the signal originated with by issuing this command. This command is used to specify projector internal settings such as whether or not to get PC signal through IP (Available only in the normal Power ON status) Note; To differentiate between 60Hz and 50Hz in 1080i and 720p, "60" or "50" is necessary to add to the parameter in this command.	
Response	Acceptable	"000" [CR]
	Unacceptable	"101" [CR] --- When input is Video signal

### 8.5.10 CF\_PCSTORE Command

Command	"CF_PCSTORE_%1" [CR]	
%1	"MODE1" ----- Store current PC Adjust status to Mode1 "MODE2" ----- Store current PC Adjust status to Mode2 "MODE3" ----- Store current PC Adjust status to Mode3 "MODE4" ----- Store current PC Adjust status to Mode4 "MODE5" ----- Store current PC Adjust status to Mode5 "MODE6" ----- Store current PC Adjust status to Mode6 "MODE7" ----- Store current PC Adjust status to Mode7 "MODE8" ----- Store current PC Adjust status to Mode8 "MODE9" ----- Store current PC Adjust status to Mode9 "MODE10" ----- Store current PC Adjust status to Mode10	
Details	Store current value of PC Adjust (each parameter status such as Total dots) to Mode1-10. This command operates the same way as storing to Mode1-10 in PC Adjust Menu. (Available only in the normal Power ON status)	
Response	Acceptable	"000" [CR]
	Unacceptable	"101" [CR] --- When input is Video signal --- When input is no signal

### 8.5.11 CF\_PCMODEFREE Command

Command	"CF_PCMODEFREE_%1" [CR]	
%1	"MODE1" ----- Set Mode1 to Free status "MODE 2" ----- Set Mode2 to Free status "MODE 3" ----- Set Mode3 to Free status "MODE 4" ----- Set Mode4 to Free status "MODE 5" ----- Set Mode5 to Free status "MODE 6" ----- Set Mode6 to Free status "MODE 7" ----- Set Mode7 to Free status "MODE 8" ----- Set Mode8 to Free status "MODE 9" ----- Set Mode9 to Free status "MODE 10" ----- Set Mode10 to Free status	
Details	Delete the data registered in Custom Mode1–10 and returns it to Free status. This command operates the same way as storing to Mode1-10 in PC Adjust Menu. (Available only in the normal Power ON status)	
Response	Acceptable	"000" [CR]
	Unacceptable	"101" [CR] --- When input is Video signal --- When input is no signal

## 8.6 Input Control Command

### 8.6.1 CF\_INPUT Command

Command	"CF_INPUT_%1" [CR]	
%1	"1" ----- Select Input 1 "2" ----- Select Input 2 "3" ----- Select Input 3 "4" ----- Select Input 4 "UP"----- Increment Input No. by 1 "DN"----- Decrement Input No. by 1	
Details	Select Input (Only valid when it is in the normal Power ON status.) This command works the same way as "INPUT" button of the projector and remote control.	
Response	Acceptable	"000" [CR]
	Unacceptable	"Error Code" [CR]

### 8.6.2 CF\_SOURCE Command

Command	"CF_SOURCE_%1" [CR]	
%1	"DIGITAL" ----- Select DVI Input "ANALOG" ----- Select Analog Input "VIDEO" ----- Select Composite Video Input "S-VIDEO" ----- Select S-Video input "YPBPR" ----- Select Y/Pb/Pr Input "YCBCR" ----- Select Y/Cb/Cr Input "SDI1" ----- Select SDI 1 Input "SDI2" ----- Select SDI 2 Input "SCART" ----- Select SCART Input "HDCP" ----- Select HDCP Input "HDWL" ----- Select HD data wireless Input	
Details	Select source of the currently selected Input. (Valid only when in the normal Power ON status.) When selected Input does not meet the requirement for the specified %1, return "101" [CR] and the command is not executed.	
Response	Acceptable	"000" [CR]
	Unacceptable	"Error Code" [CR]

### 8.6.3 CF\_INPUT1~4 Command

Command	"CF_INPUT%1_%2" [CR]	
%1	"1" ----- Specify Input 1 "2" ----- Specify Input 2 "3" ----- Specify Input 3 "4" ----- Specify Input 4	
%2	"DIGITAL" ----- Select DVI Input (Computer signal) "ANALOG" ----- Select Analog Input (Computer signal) "VIDEO" ----- Select Composite Video Input "S-VIDEO" ----- Select S-Video input "YPBPR" ----- Select Y/Pb/Pr Input "YCBCR" ----- Select Y/Cb/Cr Input "SDI1" ----- Select DF-SDI 1 Input "SDI2" ----- Select DF-SDI 2 Input "HDCP" ----- Select HDCP Input "SCART" ----- Select SCART Input "HDWL" ----- Select HD data wireless Input	
Details	Select Input specified by %1, and also Source specified by %2 concurrently. (Valid only when in the normal Power ON status.)	
Response	Acceptable	"000" [CR]
	Unacceptable	"Error Code" [CR]

### 8.6.4 CF\_SYSTEM Command

Command	"CF_SYSTEM_%1" [CR]	
%1	Input is PC Analog	"VGA1" ----- Select VGA1 "VGA2" ----- Select VGA2 : : "XGA1" ----- Select XGA1 : : "WXGA3" ----- Select WXGA3 "1080I" ----- Select 1080i "1035I" ----- Select 1035i "720P" ----- Select 720p "575P" ----- Select 575p "480P" ----- Select 480p "575I" ----- Select 575i "480I" ----- Select 480i "1080PSF/24" ----- Select 1080psf/24 "1080PSF/25" ----- Select 1080psf/25 "1080PSF/30" ----- Select 1080psf/30 "MODE1 - 10" ----- Select MODE1 – MODE10 "EXT11 - 60" ----- Select Ex Mode11-60 * Mode1-10 is not returned.
	Input is PC Digital/AV HDCP	"D-XGA1" ----- Select D-XGA1 : : "D-WXGA3" ----- Select D-WXGA3 "D-1080I" ----- Select D-1080i "D-1035I" ----- Select D-1035i "D-720P" ----- Select D-720p "D-575P" ----- Select D-575p "D-480P" ----- Select D-480p "D-1080PSF/24" ----- Select D-1080psf/24 "D-1080PSF/25" ----- Select D-1080psf/25 "D-1080PSF/30" ----- Select D-1080psf/30
	Input is Y,Pb/Cb,Pr/Cr	"AUTO" ----- Select System "Auto" "1080I" ----- Select 1080i "1035I" ----- Select 1035i "720P" ----- Select 720p "575P" ----- Select 575p "480P" ----- Select 480p "575I" ----- Select 575i "480I" ----- Select 480i
	Input is Video / S-Video	"AUTO" ----- Select System "Auto" "NTSC" ----- Select NTSC "NTSC443" ----- Select NTSC4.43 "PAL" ----- Select PAL "SECAM" ----- Select SECAM "PAL-M" ----- Select PAL-M "PAL-N" ----- Select PAL-N
Details	Select System of currently selected Input (Available only in the normal Power ON status) When selected input does not include specified %1, error code "101" [CR] is returned and it is not executed.	
Response	Acceptable	"000" [CR]
	Unacceptable	"Error Code" [CR]

## 8.7 Screen Control Command

### 8.7.1 CF\_SCREEN Command

Command	"CF_SCREEN_%1" [CR]	
%1	Input is PC signal	"NORMAL" ----- Select Normal mode "TRUE" ----- Select True mode "WIDE" ----- Select Wide mode "FULL" ----- Select Full mode "CUSTOM" ----- Select Custom mode "DZOOM□UP" ----- Expand image size by Digital Zoom "DZOOM□DN" ----- Compress image size by Digital Zoom "UP" ----- Select screen size with forward switching in possible range (Normal → True → Wide → Full → Custom → Normal → ...) "DN" ----- Select screen size with backward switching in possible range (Normal → Custom → Full → Wide → True → Normal → ...)
	Input is Video signal	"NORMAL" ----- Select Normal mode "WIDE" ----- Select Wide mode "CUSTOM" ----- Select Custom mode "UP" ----- Select screen size with forward switching in possible range (Normal → Wide → Custom → Normal → Wide → ...) "DN" ----- Select screen size with backward switching in possible range (Normal → Custom → Wide → Normal → Custom → ...)
	Common in AV/PC	"RST" ----- Reset Screen adjustment
Details	Select screen size. (Valid only when in the normal Power ON status.) When selected Input does not meet the requirement for the specified %1, return "101" [CR] and the command is not executed.	
Response	Acceptable	"000" [CR]
	Unacceptable	"Error Code" [CR]

### 8.7.2 CF\_DZCENT Command

Command	"CF_DZCENT_%1" [CR]	
%1	"CENT" ----- Cancel Digital Zoom (CENT: "CENTER")	
Details	Cancel Digital Zoom mode. (Valid only when in the normal Power ON status and Input for Computer is selected.)	
Response	Acceptable	"000" [CR]
	Unacceptable	"101" [CR] ----- When input is Video

### 8.7.3 CF\_KEYSTONE Command

Command	"CF_KEYSTONE_%1" [CR]	
%1	"UP" ----- Correct Keystone distortion to reduce upper part of image "FUP" ----- Correct Keystone distortion to reduce upper part "DN" ----- Correct Keystone distortion to reduce lower part of image "FDN" ----- Correct Keystone distortion to reduce lower part largely "LEFT" ----- Correct Keystone distortion to reduce left part of image "FLFT" ----- Correct Keystone distortion to reduce left part largely "RIGHT" ----- Correct Keystone distortion to reduce right part of image "FRGT" ----- Correct Keystone distortion to reduce right part largely "RST" ----- Set Keystone OFF	
Details	Change level of Keystone distortion correction (Available only in the normal Power ON status). When reached the limit of the correction level, projector accepts the command but does not execute it. Receiving this command immediately invokes the operation. When trying to set the value beyond available range, error code "201" is returned and the operation is not executed. Example 1: When the correction level of the right part has reached its upper limit and then the command "RIGHT" is received Example 2: When the upper part correction allows only another step, and then the command "FUP" is received.	
Response	Acceptable	"000" [CR]
	Unacceptable	"Error Code" [CR]

### 8.7.4 CF\_KEYSTONEMODE Command

Command	"CF_KYSTNMODE_%1" [CR]	
%1	"STR" ----- Set Keystone store mode to Store "RST" ----- Set Keystone store mode to Reset	
Details	Set Keystone store mode (Available only in the normal Power ON status)	
Response	Acceptable	"000" [CR]
	Unacceptable	"Error Code" [CR]

### 8.7.5 CF\_CEIL Command

Command	"CF_CEIL_%1" [CR]	
%1	"ON" ----- Set Ceiling to ON "OFF" ----- Set Ceiling to OFF	
Details	Set/Cancel Ceiling. (Valid only when in the normal Power ON status.) When Ceiling is set to ON, image is left/right as well as top/bottom reversed. The status set by this command is stored in EEPROM and the setting remains effective after the power is turned to ALL OFF status.	
Response	Acceptable	"000" [CR]
	Unacceptable	"Error Code" [CR]

### 8.7.6 CF\_REAR Command

Command	"CF_REAR_%1" [CR]	
%1	"ON" ----- Set Rear to ON "OFF" ----- Set Rear to OFF	
Details	Set/Cancel Rear. (Valid only when in the normal Power ON status.) When Rear is set to ON, image is left/right reversed. The status set by this command is stored in EEPROM and the setting remains effective after the power is turned to ALL OFF status.	
Response	Acceptable	"000" [CR]
	Unacceptable	"Error Code" [CR]

### 8.7.7 CF\_VSCALE Command

Command	"CF_VSCALE_%1" [CR]	
%1	"035" ----- +35 "031" ----- +31 : "001" ----- +1 "000" ----- ±0 " - 01" ----- - 1 : " - 31" ----- - 31 " - 32" ----- - 32 "UP" ----- Increment setting value of Vscale by 1 "DN" ----- Decrement setting value of Vscale by 1	
Details	Set Vscale (Available only in the normal Power ON status) *When selected screen mode is a setting except Custom, return "101" [CR] and the command is not executed. * When input is no signal, return "101" [CR] and the command is not executed.	
Response	Acceptable	"000" [CR]
	Unacceptable	"Error Code" [CR]

### 8.7.8 CF\_VPOS Command

Command	"CF_VPOS_%1" [CR]	
%1	"015" ----- +15 "014" ----- +14 : "001" ----- +1 "000" ----- ±0 " - 01" ----- - 1 : " - 14" ----- - 14 " - 15" ----- - 15 "UP" ----- Increment setting value of Vposition by 1 "DN" ----- Decrement setting value of Vposition by 1	
Details	Set V Position (Available only in the normal Power ON status) *When selected screen mode is a setting except Custom, return "101" [CR] and the command is not executed. * When input is no signal, return "101" [CR] and the command is not executed.	
Response	Acceptable	"000" [CR]
	Unacceptable	"Error Code" [CR]

### 8.7.9 CF\_HSCALE Command

Command	"CF_HSCALE_%1" [CR]	
%1	"035" ----- +35 "031" ----- +31 : "002" ----- +2 "001" ----- +1 "000" ----- ±0 " - 01" ----- - 1 " - 02" ----- - 2 : " - 31" ----- - 31 " - 32" ----- - 32 "UP" ----- Increment setting value of Hscale by 1 "DN" ----- Decrement setting value of Hscale by 1	
Details	Set Hscale (Available only in the normal Power ON status) *When selected screen mode is a setting except Custom, return "101" [CR] and the command is not executed. * When input is no signal, return "101" [CR] and the command is not executed.	
Response	Acceptable	"000" [CR]
	Unacceptable	"Error Code" [CR]

### 8.7.10 CF\_HPOS Command

Command	"CF_HPOS_%1" [CR]	
%1	"015" ----- +15 "014" ----- +14 : "002" ----- +2 "001" ----- +1 "000" ----- ±0 " - 01" ----- - 1 " - 02" ----- - 2 : " - 14" ----- - 14 " - 15" ----- - 15 "UP" ----- Increment setting value of Hposition by 1 "DN" ----- Decrement setting value of Hposition by 1	
Details	Set H Position (Available only in the normal Power ON status) *When selected screen mode is a setting except Custom, return "101" [CR] and the command is not executed. * When input is no signal, return "101" [CR] and the command is not executed.	
Response	Acceptable	"000" [CR]
	Unacceptable	"Error Code" [CR]

## 8.8 Lamp Command

### 8.8.1 CF\_LAMPH Command

Command	"CF_LAMPH_%1" [CR]	
%1	"RSTn" (n=1-2) ----- Reset lamp 1-2 running time	
Details	Reset running time of the lamp specified in "n". (Valid only when it is in the normal Power ON status.)	
Response	Acceptable	"000" [CR]
	Unacceptable	"Error Code" [CR]

### 8.8.2 CF\_LAMPMODE Command

Command	"CF_LAMPMODE_%1" [CR]	
%1	"FULL" ----- Set lamp mode to 2-lamp (FULL) "HALF" ----- Set lamp mode to 1-lamp (HALF)	
Details	Select Lamp mode. (Valid only when in the normal Power ON status.) The value set by this command is stored in EEPROM and the setting remains effective after the power is turned to ALL OFF status. On Half mode, one lamp with a fewer used-time light automatically.	
Response	Acceptable	"000" [CR]
	Unacceptable	"Error Code" [CR]

### 8.8.3 CF\_AUTOLAMPCTRL Command

Command	"CF_AUTOLAMPCTRL_%1" [CR]	
%1	"NORMAL" ----- Set lamp control mode to NORMAL "ECO" ----- Set lamp control mode to ECO "AUTO" ----- Set lamp control mode to AUTO	
Details	Select Lamp control mode. (Valid only when in the normal Power ON status.) The value set by this command is stored in EEPROM and the setting remains effective after the power is turned to ALL OFF status.	
Response	Acceptable	"000" [CR]
	Unacceptable	"Error Code" [CR]

## 8.9 Setting Command

### 8.9.1 CF\_LANG Command

Command	"CF_LANG_%1" [CR]	
%1	"ENG" ----- Select ENGLISH "DEU" ----- Select German "FRA" ----- Select French "ITA" ----- Select Italian "ESP" ----- Select Spanish "POR" ----- Select Portuguese "NED" ----- Select Dutch "SVE" ----- Select Swedish "JPN" ----- Select Japanese "CHI" ----- Select Chinese "KOR" ----- Select Korean "RUS" ----- Select Russian	
Details	Select language for OSD. (Valid only when in the normal Power ON status.) The language set by this command is stored in EEPROM and the setting remains effective after the power is turned to ALL OFF status.	
Response	Acceptable	"000" [CR]
	Unacceptable	"Error Code" [CR]

### 8.9.2 CF\_DISP Command

Command	"CF_DISP_%1" [CR]	
%1	"ON" ----- Set Display to ON "CNTDWN OFF" ----- Set Display to Count down Off "OFF" ----- Set Display to OFF "UP" ----- Switch forward (On → Count down Off → Off → On → ---) "DN" ----- Switch backward (On → Off → Count down Off → On → ---)	
Details	Set/Cancel Display. (Valid only when in the normal Power ON status.) The value set by this command is stored in EEPROM and the setting remains effective after the power is turned to ALL OFF status.	
Response	Acceptable	"000" [CR]
	Unacceptable	"Error Code" [CR]

### 8.9.3 CF\_BACKGND Command

Command	"CF_BACKGND_%1" [CR]	
%1	"BLUE" ----- Select Blue Back "USER" ----- Select User "BLACK" ----- Select Black Back "UP" ----- Switch forward (Blue Back→User→Black Back→Blue Back) "DN" ----- Switch backward (Blue Back→Black Back→User→Blue Back)	
Details	Set Screen status for no signal. (Available only in the normal Power ON status) The status set by this command is stored in EEPROM and the setting remains even after the power is turned to ALL OFF status. *When %1="USER" is received, error code "101" is returned, in the case of Capture non-practice.	
Response	Acceptable	"000" [CR]
	Unacceptable	"Error Code" [CR]

### 8.9.4 CF\_LOGO Command

Command	"CF_LOGO_%1_%2" [CR]	
%1	"0000 – 9999" ----- Directly set Logo PIN code	
%2	"OFF" ----- Cancel Logo display "DFLT" ----- Select Logo of Factory Default "USER" ----- Select User "UP" ----- Select functions to choose forward (OFF → DFLT → USER → OFF → --) "DN" ----- Select functions to choose backward (OFF → USER → DFLT → OFF → --)	
Details	Set Logo mode. (Available only in the normal Power ON status) The status set by this command is stored in EEPROM and setting remains effective even after the power is turned to ALL OFF status. Set Logo PIN code in %1. When Logo Lock is enabled: PIN code is matched ----- Command is valid (Acceptable) PIN code is mismatched ----- Command is invalid (Error code "102") PIN code is beyond %1 available range ----- Command is invalid (Error code "?") When Logo Lock is disabled: PIN code is within %1 available range ----- Command is valid (Acceptable) PIN code is out of %1 available range ----- Command is invalid (Error code "?") Note: When Logo Lock is enabled, matching Logo PIN code switches Logo but Logo Lock is not cancelled (Lock status is kept). *When %2="USER" is received, error code "101" is returned, in the case of Capture non-practice.	
Response	Acceptable	"000" [CR]
	Unacceptable	"Error Code" [CR]

### 8.9.5 CF\_FANSPEED Command

Command	"CF_FANSPEED_%1" [CR]	
%1	"MAX" ----- Select Maximum speed of Fan Control "NOR" ----- Select Normal speed of Fan Control	
Details	Switch Fan Control Speed. (Valid only when in the normal Power ON status.) The status set by this command is stored in EEPROM and the setting remains effective after the power is turned to ALL OFF status.	
Response	Acceptable	"000" [CR]
	Unacceptable	"Error Code" [CR]

### 8.9.6 CF\_RCODE Command

Command	"CF_RCODE_%1" [CR]	
%1	"001" ----- Select Code 1 "002" ----- Select Code 2 "003" ----- Select Code 3 "004" ----- Select Code 4 "005" ----- Select Code 5 "006" ----- Select Code 6 "007" ----- Select Code 7 "008" ----- Select Code 8 "UP" ----- Switch forward (Code1→Code2→Code3 - - - →Code8→Code1) "DN" ----- Switch backward (Code8→Code7→Code6 - - - →Code1→Code8)	
Details	Select Remote Control Code (Valid only when in the normal Power ON status) The status set by this command is stored in EEPROM and the setting remains effective after the power is turned to ALL OFF status.	
Response	Acceptable	"000" [CR]
	Unacceptable	"Error Code" [CR]

### 8.9.7 CF\_RSENS Command

Command	"CF_RSENS_%1" [CR]	
%1	"BOTH" ----- Select both front and back receiver of projector "FRONT" ----- Select only front receiver of projector "BACK" ----- Select only back receiver of projector "UP" ----- Switch forward (BOTH → FRONT → BACK → BOTH) "DN" ----- Switch backward (BACK → FRONT → BOTH → BACK)	
Details	Select location of infrared remote receiver of remote control (Available only in the normal Power ON status) The status set by this command is stored in EEPROM and setting remains effective even after the power is turned to ALL OFF status.	
Response	Acceptable	"000" [CR]
	Unacceptable	"Error Code" [CR]

### 8.9.8 CF\_P-MANE Command

Command	"CF_P-MANE_%1" [CR]	
%1	"OFF" ----- Set Power Management to Off "READY" ----- Set Power Management to Ready "SHUTDOWN" ----- Set Power Management to Shut Down mode "UP" ----- Switch forward (Off→Ready→Shut down→Off) "DN" ----- Switch backward (Off→Shut down→Ready→Off)	
Details	Set/Cancel Power Management. (Valid only when in the normal Power ON status.) The status set by this command is stored in EEPROM and the setting remains effective after the power is turned to ALL OFF status.	
Response	Acceptable	"000" [CR]
	Unacceptable	"Error Code" [CR]

### 8.9.9 CF\_P-MANETIME Command

Command	"CF_P-MANETIME_%1" [CR]	
%1	"01" - "30" ----- Directly specify setting time by the minute "UP" ----- Increment value by 1 (Switched in 01→02→--- → 30 → 01 order) "DN" ----- Decrement value by 1 (Switched in 30→29→--- → 01 → 30 order)	
Details	Set time of Power Management time (Available only in the normal Power ON status). The status set by this command is stored in EEPROM and setting remains effective even after the power is turned to ALL OFF status.	
Response	Acceptable	"000" [CR]
	Unacceptable	"Error Code" [CR]

### 8.9.10 CF\_ON-STA Command

Command	"CF_ON-STA_%1" [CR]	
%1	"ON" ----- Set Power On Start to ON. "OFF" ----- Set Power On Start to OFF. "UP" ----- Toggle between ON and OFF.(On→Off→On → ---) "DN" ----- Toggle between ON and OFF.(On→Off→On → ---) **"UP" and "DN" are exactly same operation.	
Details	Set/Cancel Power ON Start (Only valid when it is in the normal Power ON status) The status set by this command is stored in EEPROM and the setting remains effective after the power is turned to ALL OFF status.	
Response	Acceptable	"000" [CR]
	Unacceptable	"Error Code" [CR]

### 8.9.11 CF\_PJPINCODE Command

Command	"CF_PJPINCODE_%1" [CR]	
%1	"0000 – 9999" ----- Directly specify PJ PIN code	
Details	<p>Enter PIN code to cancel PIN code lock (Available only in the normal Power ON status)                      PIN code can not be changed. (Only PIN code lock is canceled.)                      *When PIN code Lock is enabled:                      PIN code is matched ----- Command is valid (Acceptable)                      PIN code is mismatched ----- Command is invalid (Error code "102")                      PIN code is beyond %1 available range ---- Command is invalid (Error code "?")                      When PIN code lock is canceled:                      PIN code is within %1 range ----- Command is valid (Acceptable)                      PIN code is out of %1 range ----- Command is invalid (Error code is 102)</p> <p>This command is only valid when "PJ PIN code" dialog is displayed to enter PIN code after Power is ON and Countdown is completed.                      When PIN code lock is set to "On1", it needs to send this command every time the projector is turned on.</p>	
Response	Acceptable	"000" [CR]
	Unacceptable	"Error Code" [CR]

### 8.9.12 CF\_FILH Command

Command	"CF_FILH_%1" [CR]	
%1	"RST" ----- Reset Filter used time	
Details	Reset used time for filter of projector	
Response	Acceptable	"000" [CR]
	Unacceptable	"Error Code" [CR]

### 8.9.13 CF\_FILTERTIMER Command

Command	"CF_FILTERTIMER_%1" [CR]	
%1	"0400" ----- Set 400 hours "0700" ----- Set 700 hours "1000" ----- Set 1000 hours "OFF" ----- Set Off(Do not warning display)	
Details	Set time to display Filter cleaning / replacement warning on screen	
Response	Acceptable	"000" [CR]
	Unacceptable	"Error Code" [CR]

### 8.9.14 CF\_FILCTL Command

Command	"CF_FILCTL_%1" [CR]	
%1	"ROLL" ----- Execute operation of scroll of filter	
Details	Execute operation of scroll of filter	
Response	Acceptable	Acceptable
	Unacceptable	Unacceptable

### 8.9.15 CF\_FILSCRL Command

Command	"CF_FILSCRL_%1" [CR]	
%1	"RST" ----- Reset Filter scroll counter	
Details	Reset Filter scroll counter	
Response	Acceptable	Acceptable
	Unacceptable	Unacceptable

### 8.9.16 CF\_TESTPAT Command

Command	"CF_TESTPAT_%1" [CR]	
%1	"COLOR" ----- Display Color bar "GRAD1" ----- Display 16step(white→black) "GRAD2" ----- Display 16step(white←black) "GRAD3" ----- Display 16step(white↓black) "GRAD4" ----- Display 16step(white↑black) "WHITE" ----- Display all white "BLACK" ----- Display all black "CROSS" ----- Display Cross "OFF" ----- Do not show test pattern display "UP" ----- Switch forward "DN" ----- Switch backward	
Details	Execute test pattern display.(Available only in the normal Power ON status)	
Response	Acceptable	"000" [CR]
	Unacceptable	"Error Code" [CR]

### 8.9.17 CF\_FDEFAULT Command

Command	"CF_FDEFAULT_%1" [CR]	
%1	"RST"	
Details	Return the settings to Factory Default status (Valid only when in the normal Power ON status)	
Response	Acceptable	"000" [CR]
	Unacceptable	"Error Code" [CR]

### 8.9.18 CF\_KEYDIS Command

Command	"CF_KEYDIS_%1" [CR]	
%1	"NONE" ----- RC & KEY are valid "RC" ----- RC is invalid "KEY" ----- KEY is invalid	
Details	Set the limitation of RC/KEY use (Valid only when in the normal Power ON status)	
Response	Acceptable	"000" [CR]
	Unacceptable	"Error Code" [CR]

### 8.9.19 CF\_SHUTRCPROT Command

Command	"CF_SHUTRCPROT_%1" [CR]	
%1	"ON" ----- Disable RC key from controlling Shutter (Protection On) "OFF" ----- Enable RC key to control Shutter (Protection Off)	
Details	Set valid / invalid of RC use on Shutter control function (Valid only when in the normal Power ON status)	
Response	Acceptable	"000" [CR]
	Unacceptable	"Error Code" [CR]

### 8.9.20 CF\_SHUTKEYPROT Command

Command	"CF_SHUTKEYPROT_%1" [CR]	
%1	"ON" ----- Disable key on the top panel from controlling Shutter (Protection On) "OFF" ----- Enable key on the top panel to control Shutter (Protection Off)	
Details	Set valid / invalid use of key on the top panel on Shutter control function. (Valid only when in the normal Power ON status)	
Response	Acceptable	"000" [CR]
	Unacceptable	"Error Code" [CR]

### 8.9.21 CF\_SHUTH Command

Command	"CF_SHUTH_%1" [CR]	
%1	"005"- "180"-----Specify setting time directly "UP" ----- Add 1 minute "DN" -----Decrease 1 minute	
Details	Set time of operating shutter management function. (Valid only when in the normal Power ON status) The status set by this command is stored in EEPROM and setting remains effective even after the power is turned to ALL OFF status.	
Response	Acceptable	"000" [CR]
	Unacceptable	"Error Code" [CR]

## 8.10 Other Command

### 8.10.1 CF\_SHUTTER Command

Command	"CF_SHUTTER_%1" [CR]	
%1	"OPEN"----- Open Shutter "CLOSE" ----- Close Shutter	
Details	Control OPEN / CLOSE of Shutter (Valid only when in the normal Power ON status)	
Response	Acceptable	"000" [CR]
	Unacceptable	"Error Code" [CR]

## 8.11 HD data wireless Command

### 8.11.1 CF\_HDWLMODE Command

Command	"CF_HDWLMODE_%1" [CR]	
%1	"SINGLE"----- 1-1 mode "BROADCAST" ----- 1-N mode	
Details	Set communication mode with a radio transmitter. (Valid only when HD-wireless input is selected)	
Response	Acceptable	"000" [CR]
	Unacceptable	"Error Code" [CR]

### 8.11.2 CF\_HDWLAUTH Command

Command	"CF_HDWLAUTH_%1" [CR]	
%1	"EXECUTE"----- Perform the authentication between Tx-Rx. "RST" -----Reset the authentication between Tx-Rx.	
Details	Perform / Reset the authentication between Tx-Rx. (Valid only when HD-wireless input is selected and Single mode is set)	
Response	Acceptable	"000" [CR]
	Unacceptable	"Error Code" [CR]

### 8.11.3 CF\_HDWLINID Command

Command	"CF_HDWLINID_%1" [CR]	
%1	"*****" (Eight digits)---- ID of Tx * is shown in capitalized letter, from 0 - F.	
Details	Set the Input ID of the transmitters when Broadcast mode is selected (Valid only when HD-wireless input is selected and Broadcast mode is set)	
Response	Acceptable	"000" [CR]
	Unacceptable	"Error Code" [CR]

### 8.11.4 CF\_HDWLFDEF Command

Command	"CF_HDWLFDEF_%1" [CR]	
%1	"RST"-----Return the settings to Factory default status of HD -wireless setting	
Details	Return the settings to Factory Default status of HD data wireless setting *Valid only when HD-wireless input is selected * The projector-related setting does not return to Factory default status	
Response	Acceptable	"000" [CR]
	Unacceptable	"Error Code" [CR]

## 9. Status Read Command

### 9.1 Format

- 1) PC issues a command in the format below:

**"CR\_Command" [CR]**

Command: String

- 2) When the projector receives the applicable command, it returns the required information as a data string.

**"000\_" %1 [CR]**

%1: required Information (a data string. Refer to [Basic Status Read Command Table])

- 3) When the received data cannot be decoded, the projector returns **"?" [CR]**

### 9.2 Transfer Example

Getting total dots of the projector by Expand Serial Commands

PC → PJ: "CR\_TDOTS" [CR]

PC ← PJ: "000\_1344" [CR]

### 9.3 Operation condition

Basically it should be always operated.

## 9.4 Image Status Read Commands

### 9.4.1 CR\_CONT Command

Command	"CR_CONT" [CR]	
Details	Get user controlled value of Contrast	
Response	Acceptable	"000_%1" [CR]
	%1	"000" – "063"
	Unacceptable	"?" [CR]

### 9.4.2 CR\_BRIGHT Command

Command	"CR_BRIGHT" [CR]	
Details	Get user controlled value of Brightness	
Response	Acceptable	"000_%1" [CR]
	%1	"000" – "063"
	Unacceptable	"?" [CR]

### 9.4.3 CR\_COLOR Command

Command	"CR_COLOR" [CR]	
Details	Get user controlled value of Color	
Response	Acceptable	"000_%1" [CR]
	%1	"000" – "063"
	Unacceptable	"Error Code" [CR] -----When command is invalid in the given condition (such as being selected input) "?" [CR] ----- When unknown command is received

### 9.4.4 CR\_TINT Command

Command	"CR_TINT" CR]	
Details	Get user controlled value of Tint	
Response	Acceptable	"000_%1" [CR]
	%1	"000" – "063"
	Unacceptable	"Error Code" [CR] -----When command is invalid in the given condition (such as being selected input) "?" [CR] ----- When unknown command is received

### 9.4.5 CR\_APCTRL Command

Command	"CR_APCTRL" [CR]	
Details	Get setting status of Auto Picture Control	
Response	Acceptable	"000_%1" [CR]
	%1	"L1" ----- Operate Auto Picture Control with Level1 "L2" ----- Operate Auto Picture Control with Level2 "OFF" ----- Set Auto Picture Control OFF
	Unacceptable	"?" [CR]

#### 9.4.6 CR\_COLTEMP Command

Command	"CR_COLTEMP" [CR]	
Details	Get Color Temperature setting status	
Response	Acceptable	"000_%1" [CR]
	%1	"000" ~"003" "BLANK" ---- OSD Menu is blank (Neither of Xlow / Low / Mid / High)
	Unacceptable	"?" [CR]

#### 9.4.7 CR\_WBAL-R Command

Command	"CR_WBAL-R" [CR]	
Details	Get user controlled Red value of White Balance	
Response	Acceptable	"000_%1" [CR]
	%1	"000" – "063"
	Unacceptable	"?" [CR]

#### 9.4.8 CR\_WBAL-G Command

Command	"CR_WBAL-G" [CR]	
Details	Get user controlled Green value of White Balance	
Response	Acceptable	"000_%1" [CR]
	%1	"000" – "063"
	Unacceptable	"?" [CR]

#### 9.4.9 CR\_WBAL-B Command

Command	"CR_WBAL-B" [CR]	
Details	Get user controlled Blue value of White Balance	
Response	Acceptable	"000_%1" [CR]
	%1	"000" – "063"
	Unacceptable	"?" [CR]

#### 9.4.10 CR\_OFFSET-R Command

Command	"CR_OFFSET-R" [CR]	
Details	Get user controlled Red value of Offset	
Response	Acceptable	"000_%1" [CR]
	%1	"000" – "063"
	Unacceptable	"?" [CR]

#### 9.4.11 CR\_OFFSET-G Command

Command	"CR_OFFSET-G" [CR]	
Details	Get user controlled Green value of Offset	
Response	Acceptable	"000_%1" [CR]
	%1	"000" – "063"
	Unacceptable	"?" [CR]

#### 9.4.12 CR\_OFFSET-B Command

Command	"CR_OFFSET-B" [CR]	
Details	Get user controlled Blue value of Offset	
Response	Acceptable	"000_%1" [CR]
	%1	"000" – "063"
	Unacceptable	"?" [CR]

#### 9.4.13 CR\_SHARP Command

Command	"CR_SHARP" [CR]	
Details	Get user controlled value of Sharpness	
Response	Acceptable	"000_%1" [CR]
	%1	"000" – "031"
	Unacceptable	"?" [CR]

#### 9.4.14 CR\_GAMMA Command

Command	"CR_GAMMA" [CR]	
Details	Get user controlled value of Gamma	
Response	Acceptable	"000_%1" [CR]
	%1	"000" – "015"
	Unacceptable	"?" [CR]

#### 9.4.15 CR\_NZRED Command

Command	"CR_NZRED" [CR]	
Details	Get Noise Reduction setting status	
Response	Acceptable	"000_%1" [CR]
	%1	"ON" ----- Noise Reduction is ON "OFF" ----- Noise Reduction is OFF
	Unacceptable	"Error Code" [CR] -----When command is invalid in the given condition (such as being selected input) "?" [CR] ----- When unknown command is received

#### 9.4.16 CR\_PROGV Command

Command	"CR_PROGV" [CR]	
Details	Get Progressive scan setting status	
Response	Acceptable	"000_%1" [CR]
	%1	"ON" ----- Set Progressive scan On "FILM" ----- Select FILM mode "OFF" ----- Set Progressive scan Off
	Unacceptable	"Error Code" [CR] -----When command is invalid in the given condition (such as being selected input) "?" [CR] ----- When unknown command is received

### 9.4.17 CR\_IMAGE Command

Command	"CR_IMAGE" [CR]	
Details	Get image setting status. The Required data "CUSTOM1" – "CUSTOM10" corresponds to "Image1" – "Image10" displayed when selecting Image on OSD Menu.	
Response	Acceptable	"000_%1" [CR]
	%1	"STAND" ----- Standard "REAL" ----- Real "CINEMA" ----- Cinema "CUSTOM1" ----- "Image1" "CUSTOM2" ----- "Image2" "CUSTOM3" ----- "Image3" "CUSTOM4" ----- "Image4" "CUSTOM5" ----- "Image5" "CUSTOM6" ----- "Image6" "CUSTOM7" ----- "Image7" "CUSTOM8" ----- "Image8" "CUSTOM9" ----- "Image9" "CUSTOM10" ----- "Image10"
	Unacceptable	"Error Code" [CR] ----- When command is invalid in the given condition (such as being selected input) "?" [CR] ----- When unknown command is received

### 9.4.18 CR\_IMGGMD Command

Command	"CR_IMGGMD" [CR]	
Details	Get setting status of Standard/Real/Cinema in Image Gamma	
Response	Acceptable	"000_%1" [CR]
	%1	"STD" ----- Standard "REL" ----- Real "CNM" ----- Cinema
	Unacceptable	"?" [CR]

### 9.4.19 CR\_ADVCOL Command

Command	"CR_ADVCOL" [CR]	
Details	Get setting status of Advanced color	
Response	Acceptable	"000_%1" [CR]
	%1	"AUTO" ----- Operate Advanced color with Auto "OFF" ----- Set Advanced color OFF
	Unacceptable	"?" [CR]

## 9.5 PC Status Read Commands

### 9.5.1 CR\_FSYNC Command

Command	"CR_FSYNC" [CR]	
Details	Get value of Fine Sync	
Response	Acceptable	"000_%1" [CR]
	%1	"0000" – "0031"
	Unacceptable	"Error Code" [CR] ----- When command is invalid in the given condition (such as being selected input) "?" [CR] ----- When unknown command is received

### 9.5.2 CR\_TDOTS Command

Command	"CR_TDOTS" [CR]	
Details	Get value of Total Dots	
Response	Acceptable	"000_%1" [CR]
	%1	"mmmm" – "nnnn" (mmmm = Display area H + Position H) (nnnn = Maximum value less than 140 MHz of Dot Clock)
	Unacceptable	"Error Code" [CR] ----- When command is invalid in the given condition (such as being selected input) "?" [CR] ----- When unknown command is received

### 9.5.3 CR\_H-POS Command

Command	"CR_H-POS" [CR]	
Details	Get value of Horizontal Position	
Response	Acceptable	"000_%1" [CR]
	%1	"0000" – "nnnn" (nnnn = Total Dots - Display Area H)
	Unacceptable	"Error Code" [CR] ----- When command is invalid in the given condition (such as being selected input) "?" [CR] ----- When unknown command is received

### 9.5.4 CR\_V-POS Command

Command	"CR_V-POS" [CR]	
Details	Get value of Vertical Position	
Response	Acceptable	"000_%1" [CR]
	%1	"0000" – "nnnn" (nnnn = Total Line - Display Area V)
	Unacceptable	"Error Code" [CR] ----- When command is invalid in the given condition (such as being selected input) "?" [CR] ----- When unknown command is received

### 9.5.5 CR\_CLAMP Command

Command	"CR_CLAMP" [CR]	
Details	Get value of Clamp	
Response	Acceptable	"000_%1" [CR]
	%1	"0000" – " 4095"
	Unacceptable	"Error Code" [CR] ----- When command is invalid in the given condition (such as being selected input) "?" [CR] ----- When unknown command is received

### 9.5.6 CR\_DDOTS Command

Command	"CR_DDOTS" [CR]	
Details	Get value of Display Dots	
Response	Acceptable	"000_%1" [CR]
	%1	"0256".nnnn" (nnnn = Total Dots – Position H)
	Unacceptable	"Error Code" [CR] ----- When command is invalid in the given condition (such as being selected input) "?" [CR] ----- When unknown command is received

### 9.5.7 CR\_DLINE Command

Command	"CR_DLINE" [CR]	
Details	Get value of Display Line	
Response	Acceptable	"000_%1" [CR]
	%1	"0100" – " nnnn" (nnnn = Total Line – Position V)
	Unacceptable	"Error Code" [CR] ----- When command is invalid in the given condition (such as being selected input) "?" [CR] ----- When unknown command is received

### 9.5.8 CR\_SETPCADJ Command

Command	"CR_SETPCADJ" [CR]	
Details	Get PC signal for current system	
Response	Acceptable	"000_%1" [CR]
	%1	<p>When input signal is PC Analog;</p> <p>"VGA1" ----- Indicates VGA1 is selected</p> <p>"VGA2" ----- Indicates VGA2 is selected</p> <p>  :</p> <p>"XGA1" ----- Indicates XGA1 is selected</p> <p>  :</p> <p>"WXGA3" ----- Indicates WXGA3 is selected</p> <p>"1080I" ----- Indicates 1080i is selected</p> <p>"1035I" ----- Indicates 10350i is selected</p> <p>"720P" ----- Indicates 720p is selected</p> <p>"575P" ----- Indicates 575p is selected</p> <p>"480P" ----- Indicates 480p is selected</p> <p>"575I" ----- Indicates 575i is selected</p> <p>"480I" ----- Indicates 480i is selected</p> <p>"1080PSF/24" ----- Indicates 1080psf/24 is selected</p> <p>"1080PSF/25" ----- Indicates 1080psf/25 is selected</p> <p>"1080PSF/30" ----- Indicates 1080psf/30 is selected</p> <p>  :</p> <p>"MODE10" ----- Indicates Mode10 is selected</p> <p>"EXT11" ----- EXT11 is selected</p> <p>  :</p> <p>"EXT60" ----- EXT60 is selected</p> <p>* Error Code "101" [CR] is returned for no signal.</p> <p>* When input signal is not PC Analog, error code "101" is returned.</p>
	Unacceptable	"?" [CR]

### 9.5.9 CR\_ORGMODE Command

Command	"CR_ORGMODE" [CR]	
Details	Get the original signal of current selected Mode that is set in PC Adj. When MODE1- 10 or EXT11-60 is not selected, get the current signal.	
Response	Acceptable	"000_%1" [CR]
	%1	When input signal is PC Analog; "VGA1" ----- Indicates signal is VGA1 "VGA2" ----- Indicates signal is VGA2 : : "XGA1" ----- Indicates signal is XGA1 : : "WXGA3" ----- Indicates signal is WXGA3 "1080i60" ----- Indicates signal is 1080i60 "1080i50" ----- Indicates signal is 1080i50 "1035i" ----- Indicates signal is 1035i "720P60" ----- Indicates signal is 720p60 "720P50" ----- Indicates signal is 720p50 "575P" ----- Indicates signal is 575p "480P" ----- Indicates signal is 480p "575i" ----- Indicates signal is 575i "480i" ----- Indicates signal is 480i "1080PSF/24" ----- Indicates signal is 1080psf/24 "1080PSF/25" ----- Indicates signal is 1080psf/25 "1080PSF/30" ----- Indicates signal is 1080psf/30 Note; To differentiate between 60Hz and 50Hz in 1080i and 720p, "60" or "50" is necessary to add to the parameter in this command * When input signal is not PC Analog, error code "101" is returned.
	Unacceptable	"?" [CR]

### 9.5.10 CR\_PCSTORE Command

Command	"CR_PCSTORE" [CR]	
Details	Get Free or Stored status of MODE1 - 5 in PC Adjust. Data consists of 10 bytes and each byte represents MODE1-10.(F:Free, S:Stored)	
Response	Acceptable	"000_%1" [CR]
	%1	"FFFFFFFF" ----- ALL Free "SFFFFFFFF" ----- Mode1 is Stored, others are Free : "FFFFFFFFS" ----- Mode10 is Stored, others are Free "SSSSSSSSS" ----- ALL Stored
	Unacceptable	"Error Code" [CR] ----- When command is invalid in the given condition (such as being selected input) "?" [CR] ----- When unknown command is received

## 9.6 Video Status Read Command

### 9.6.1 CR\_SERSYS Command

Command	"CR_SERSYS" [CR]	
Details	Get currently selected signal. Value only when Input is video. (Invalid when Input is computer)	
Response	Acceptable	"000_%1" [CR]
	%1	"1080I60" ----- 1080i 60Hz "1080I50" ----- 1080i 50Hz "1035I" ----- 1035i "720P60" ----- 720p 60Hz "720P50" ----- 720p 50Hz "575P" ----- 575p "480P" ----- 480p "575I" ----- 575i (includes composite signal such as PAL) "480I" ----- 480i (includes composite signal such as NTSC) "NO_SIGNAL" ----- There is no signal
	Unacceptable	"?" [CR]

## 9.7 Input Read Command

### 9.7.1 CR\_INPUT Command

Command	"CR_INPUT" [CR]	
Details	Get selected INPUT No.	
Response	Acceptable	"000_%1" [CR]
	%1	"1" – "4"
	Unacceptable	"?" [CR]

### 9.7.2 CR\_SOURCE Command

Command	"CR_SOURCE" [CR]	
Details	Get selected Source	
Response	Acceptable	"000_%1" [CR]
	%1	"DIGITAL" ----- DVI Input is selected "ANALOG" ----- ANALOG RGB is selected "VIDEO" ----- Video Input is selected "S-VIDEO" ----- S-VIDEO Input is selected "YPBPR" ----- Y/Pb/Pr Input is selected "SDI1" ----- DF-SDI1 Input is selected "SDI2" ----- DF-SDI2 Input is selected "HDCP" ----- HDCP Input is selected "SCART" ----- SCART Input is selected "HDWL" ----- HD data wireless input is selected "BLANK" ----- without Source (LAN card) "NOCARD" ----- There is no board inserted
	Unacceptable	"Error Code" [CR] ----- When command is invalid in the given condition (such as being selected input) "?" [CR] ----- When unknown command is received

**9.7.3 CR\_SYSTEM Command**

Command	"CR_SYSTEM" [CR]		
Details	Get selected System		
Response	Acceptable	"000_%1" [CR]	
	%1	Input is PC Analog	"VGA1" ----- indicates VGA1 is selected "VGA2" ----- indicates VGA2 is selected : : "XGA1" ----- indicates XGA1 is selected : "WXGA3" ----- indicates WXGA3 is selected "1080I" ----- indicates 1080i is selected "1035I" ----- indicates 1035i is selected "720P" ----- indicates 720p is selected "575P" ----- indicates 575p is selected "480P" ----- indicates 480p is selected "575I" ----- indicates 575i is selected "480I" ----- indicates 480i is selected "1080PSF/24" ----- indicates 1080psf/24 is selected "1080PSF/25" ----- indicates 1080psf/25 is selected "1080PSF/30" ----- indicates 1080psf/30 is selected "MODE1" ----- indicates Mode1 is selected : "MODE10" ----- indicates Mode10 is selected "EXT11" ----- indicates EXT11 is selected : "EXT60" ----- indicates EXT60 is selected * Error Code "101" [CR] is returned for no signal
		Input is PC-Digital/AV-HDCP	"D-XGA1" ----- indicates D-XGA1 is selected : "D-WXGA3" ----- indicates D-WXGA3 is selected "D-1080I" ----- indicates D-1080i is selected "D-1035I" ----- indicates D-1035i is selected "D-720P" ----- indicates D-720p is selected "D-575P" ----- indicates D-575p is selected "D-480P" ----- indicates D-480p is selected "D-1080PSF/24" ----- indicates D-1080psf/24 is selected "D-1080PSF/25" ----- indicates D-1080psf/25 is selected "D-1080PSF/30" ----- indicates D-1080psf/30 is selected * Error Code "101" [CR] is returned for no signal
		Input is Y,Pb/Cb,Pr/Cr	"AUTO" ----- indicates Auto is selected "1080I" ----- indicates 1080i60Hz is selected "1035I" ----- indicates 1035i is selected "720P" ----- indicates 720p is selected "575P" ----- indicates 575p is selected "480P" ----- indicates 480p is selected "575I" ----- indicates 575i is selected "480I" ----- indicates 480i is selected * Selected System is returned, whether or not signal is coming.
		Input is Video or S-video	"AUTO" ----- indicates Auto is selected "NTSC" ----- indicates NTSC is selected "NTSC443" ----- indicates NTSC4.43 is selected "PAL" ----- indicates PAL is selected "SECAM" ----- indicates SECAM is selected "PAL-M" ----- indicates PAL-M is selected "PAL-N" ----- indicates PAL-N is selected * Selected System is returned, whether or not signal is coming.
Unacceptable	"Error Code" [CR]		

**9.7.4 CR\_SRCINP1 Command**

Command	"CR_SRCINP1" [CR]	
Details	Get Source of Input1	
Response	Acceptable	"000_%1" [CR]
	%1	"DIGITAL" ----- in Computer mode "ANALOG" ----- in Computer mode "VIDEO" ----- in Video mode "S-VIDEO" ----- in Video mode "YPBPR" ----- in Component mode "SDI1" ----- in DF-SDI1 mode "SDI2" ----- in DF-SDI2 mode "HDCP" ----- in HDCP mode "SCART" ----- in SCART mode "HDWL" ----- in HD-wireless mode "BLANK" ----- There is no input source (LAN card) "NOCARD" ----- There is no board inserted
	Unacceptable	"?" [CR]

**9.7.5 CR\_SRCINP2 Command**

Command	"CR_SRCINP2" [CR]	
Details	Get Source of Input 2	
Response	Acceptable	"000_%1" [CR]
	%1	The same data as CF_SRCINP1
	Unacceptable	"?" [CR]

**9.7.6 CR\_SRCINP3 Command**

Command	"CR_SRCINP3" [CR]	
Details	Get Source of Input 3	
Response	Acceptable	"000_%1" [CR]
	%1	The same data as CF_SRCINP1
	Unacceptable	"?" [CR]

**9.7.7 CR\_SRCINP4 Command**

Command	"CR_SRCINP3" [CR]	
Details	Get Source of Input 4	
Response	Acceptable	"000_%1" [CR]
	%1	The same data as CF_SRCINP1
	Unacceptable	"?" [CR]

**9.7.8 CR\_HMSLOT Command**

Command	"CR_HMSLOT" [CR]	
Details	Get the total number of Slots(Inputs)	
Response	Acceptable	"000_%1" [CR]
	%1	"004"
	Unacceptable	"?" [CR]

### 9.7.9 CR\_NMSLOT1 Command

Command	"CR_NMSLOT1" [CR]	
Details	Get the board name inserted to Slot 1	
Response	Acceptable	"000_%1" [CR]
	%1	"HDCP-DVI2" ----- Input1/ New HDCP&DVI board "5BNC-VIDEO"----- Input2/ New Video board "VGA" ----- VGA D-Sub board "NETWORK" ----- NETWORK board "5BNC" ----- Component board "DUAL-SDI" ----- HD&SD-SDI board "HDCP-DVI" ----- HDCP&DVI board "WARP" ----- Warp board "POA-MD26HDWL"----- Wireless movie card "NOTERMINAL" ----- There is no board inserted
	Unacceptable	"?" [CR]

### 9.7.10 CR\_NMSLOT2 Command

Command	"CR_NMSLOT2" [CR]	
Details	Get the board name inserted to Slot 2	
Response	Acceptable	"000_%1" [CR]
	%1	The same data as CR_NMSLOT1
	Unacceptable	"?" [CR]

### 9.7.11 CR\_NMSLOT3 Command

Command	"CR_NMSLOT3" [CR]	
Details	Get the board name inserted to Slot 3	
Response	Acceptable	"000_%1" [CR]
	%1	The same data as CR_NMSLOT1
	Unacceptable	"?" [CR]

### 9.7.12 CR\_NMSLOT4 Command

Command	"CR_NMSLOT4" [CR]	
Details	Get the board name inserted to Slot 4	
Response	Acceptable	"000_%1" [CR]
	%1	The same data as CR_NMSLOT1
	Unacceptable	"?" [CR]

**9.7.13 CR\_IDSLOT1 Command**

Command	"CR_IDSLOT1" [CR]	
Details	Get ID information on Slot 1. This command is used to recognize the inserted board and specify the valid Input source.	
Response	Acceptable	"000_%1" [CR]
	%1	"01" ----- D-sub board Valid Input Source: ANALOG "03" ----- Network board Valid Input Source: NONE (BLANK) "04" ----- Component board Valid Input Source: ANALOG, YPBPR "08" ----- DUAL-SDI board Valid Input Source: SDI1, SDI2 "09" ----- HDCP-DVI board Valid Input Source: DIGITAL, ANALOG, HDCP, SCART "10" ----- Warp board Valid Input Source: DIGITAL, HDCP "18" ----- New HDCP-DVI board Valid Input Source: DIGITAL, ANALOG, HDCP, SCART "19" ----- New Component & Video board Valid Input Source: ANALOG, YPBPR, VIDEO, S-VIDEO "20" ----- Wireless movie card Valid Input Source: HD-wireless "30" ----- On-board(DVI-DSub+D-Sub) Valid Input Source: DIGITAL, ANALOG, HDCP, SCART "42" ----- On-board(5BNC+S-video) Valid Input Source: ANALOG, YPBPR, VIDEO, S-VIDEO "99" ----- No board inserted
	Unacceptable	"?" [CR]

**9.7.14 CR\_IDSLOT2 Command**

Command	"CR_IDSLOT2" [CR]	
Details	Get ID information on Slot 2. This command is to recognize the inserted slot board and specify the valid Input source.	
Response	Acceptable	"000_%1" [CR]
	%1	The same as CR_IDSLOT1
	Unacceptable	"?" [CR]

**9.7.15 CR\_IDSLOT3 Command**

Command	"CR_IDSLOT3" [CR]	
Details	Get ID information on Slot 3. This command is to recognize the inserted slot board and specify the valid Input source.	
Response	Acceptable	"000_%1" [CR]
	%1	The same as CR_IDSLOT1
	Unacceptable	"?" [CR]

**9.7.16 CR\_IDSLOT4 Command**

Command	"CR_IDSLOT4" [CR]	
Details	Get ID information on Slot 4. This command is to recognize the inserted slot board and specify the valid Input source.	
Response	Acceptable	"000_%1" [CR]
	%1	The same as CR_IDSLOT1
	Unacceptable	"?" [CR]

## 9.8 Screen Status Read Commands

### 9.8.1 CR\_SCREEN Command

Command	"CR_SCREEN" [CR]	
Details	Get currently selected screen image size	
Response	Acceptable	"000_%1" [CR]
	%1	"NORMAL" ----- Normal mode "WIDE" ----- Wide mode "FULL" ----- Full mode "TRUE" ----- True mode "CUSTOM" ----- Custom mode
	Unacceptable	"Error Code" [CR] ----- When command is invalid in the given condition (such as being selected input) "?" [CR] ----- When unknown command is received

### 9.8.2 CR\_KYSTNMODE Command

Command	"CR_KYSTNMODE" [CR]	
Details	Get setting status of Keystone Store Mode	
Response	Acceptable	"000_%1" [CR]
	%1	"STR" ----- Store mode is "Store" "RST" ----- Store mode is "Reset"
	Unacceptable	"?" [CR] ----- When unknown command is received

### 9.8.3 CR\_CEIL Command

Command	"CR_CEIL" [CR]	
Details	Get setting status of Ceiling	
Response	Acceptable	"000_%1" [CR]
	%1	"ON" ----- Ceiling projection is enabled "OFF" ----- Ceiling projection is disabled
	Unacceptable	"Error Code" [CR]

### 9.8.4 CR\_REAR Command

Command	"CR_REAR" [CR]	
Details	Get setting status of Rear function	
Response	Acceptable	"000_%1" [CR]
	%1	"ON" ----- Rear projection is enabled "OFF" ----- Rear projection is disabled
	Unacceptable	"Error Code" [CR]

### 9.8.5 CR\_VSCALE Command

Command	"CR_VSCALE" [CR]	
Details	Get setting status of V scale	
Response	Acceptable	"000_%1" [CR]
	%1	"-32" – "035"
	Unacceptable	"Error Code" [CR]

### 9.8.6 CR\_VPOS Command

Command	"CR_VPOS" [CR]	
Details	Get setting status of V Position	
Response	Acceptable	"000_%1" [CR]
	%1	"-15"—"015"
	Unacceptable	"Error Code" [CR]

### 9.8.7 CR\_HSCALE Command

Command	"CR_HSCALE" [CR]	
Details	Get setting status of H scale	
Response	Acceptable	"000_%1" [CR]
	%1	"-32"—"035"
	Unacceptable	"Error Code" [CR]

### 9.8.8 CR\_HPOS Command

Command	"CR_HPOS" [CR]	
Details	Get setting status of H Position	
Response	Acceptable	"000_%1" [CR]
	%1	"-15"—"015"
	Unacceptable	"Error Code" [CR]

## 9.9 Lamp Status Read Commands

### 9.9.1 CR\_LAMPREPL Command

Command	"CR_LAMPREPL" [CR]	
Details	Get the information of Lamp Replacement time	
Response	Acceptable	"000_%1" [CR]
	%1	<p>"2**"</p> <p>2 ----- indicates 2 lamps are used in this model.                      * ----- indicates the status of each lamp in lamp number order.                      "Y" means the lamp operating time is over the threshold for lamp replacement, and "N" means it has not reached to.</p> <p>e.g.                      "2YN" ----- This indicates it is 2-lamp system, and Lamp #2 has not been reached to the replacement time while #1 should be replaced.</p>
	Unacceptable	"?" [CR]

### 9.9.2 CR\_LAMPMODE Command

Command	"CR_LAMPMODE" [CR]	
Details	Get Lamp mode setting status	
Response	Acceptable	"000_%1" [CR]
	%1	<p>"FULL" ----- Lamp mode is set to 2-lamp (FULL)                      "HALF" ----- Lamp mode is set to 1-lamp (HALF)</p>
	Unacceptable	"?" [CR]

### 9.9.3 CR\_AUTOLAMPCTRL Command

Command	"CR_AUTOLAMPCTRL" [CR]	
Details	Get selected Lamp control mode	
Response	Acceptable	"000_%1" [CR]
	%1	<p>"NORMAL" ----- NORMAL is selected.                      "ECO" ----- ECO is selected.                      "AUTO" ----- AUTO is selected.</p>
	Unacceptable	"Error Code" [CR]

### 9.9.4 CR\_LAMPSTS Command

Command	"CR_LAMPSTS" [CR]	
Details	Get the information of Lamp lighting status	
Response	Acceptable	"000_%1" [CR]
	%1	<p>"2**"</p> <p>The first character indicates 2 lamps are used in this model. The following characters indicate each lamp status in lamp number order as showed below.                      "I" ----- Lamp is ON                      "O" ----- Lamp is OFF                      "X" ----- Lamp Failure</p> <p>e.g.                      "2IO" ----- This indicates it is 2-lamps system, Lamp #1 is ON, and #2 is OFF.</p>
	Unacceptable	"?" [CR]

### 9.9.5 CR\_INFLAMP Command

Command	"CR_INFLAMP" [CR]	
Details	Get Lamp mode switching status	
Response	Acceptable	"000_%1" [CR]
	%1	"NML" ----- in Normal status (lamp switching operation is not active.) "CNG" ----- during lamp switching operation
	Unacceptable	"?" [CR]

### 9.9.6 CR\_PROJH Command

Command	"CR_PROJH" [CR]	
Details	Get total running time of projector (in hours)	
Response	Acceptable	"000_%1" [CR]
	%1	"0000000" – "0099999"
	Unacceptable	"?" [CR]

### 9.9.7 CR\_HMLAMP Command

Command	"CR_HMLAMP" [CR]	
Details	Get total lamp number	
Response	Acceptable	"000_%1" [CR]
	%1	"002"
	Unacceptable	"?" [CR]

### 9.9.8 CR\_LAMPH Command

Command	"CR_LAMPH" [CR]	
Details	Get Lamp running time (in hours) * return actual lamp running time	
Response	Acceptable	"000_%1_%2_%3_%4" [CR]
	%1_%2 %3_%4	Lamp 1 data comes first, and then one space, after that lamp 2 data is followed. %1 = lamp No.1 %2 = lamp No.2 %3 = lamp No.3 %4 = lamp No.4  ※ In the case of 2-lamps model, % 1 and % 2 are only used (There are no % 3 and % 4)  eg; "0410_0410_0410_0410" [CR] .... → Lamp No.1 = 410 Hours Lamp No.2 = 410 Hours Lamp No.3 = 410 Hours Lamp No.4 = 410 Hours  Note; -each data shall be 4 digits. -"9999" is returned for 10000 hours or more.
	Unacceptable	"Error Code" [CR]

## 9.10 Setting Status Read Commands

### 9.10.1 CR\_BACKGND Command

Command	"CR_BACKGND" [CR]	
Details	Get setting status of Screen for no signal	
Response	Acceptable	"000_%1" [CR]
	%1	"BLUE" ----- Blue Back is selected "USER" ----- User is selected "BLACK" ----- Black Back is selected
	Unacceptable	"Error Code" [CR]

### 9.10.2 CR\_DISP Command

Command	"CR_DISP" [CR]	
Details	Get Display setting status	
Response	Acceptable	"000_%1" [CR]
	%1	"ON" ----- Display is set to ON. "CNTDWN OFF" ----- Display is set to Count down OFF. "OFF" ----- Display is set to OFF.
	Unacceptable	"?" [CR]

### 9.10.3 CR\_LOGO Command

Command	"CR_LOGO" [CR]	
Details	Get Logo setting status	
Response	Acceptable	"000_%1" [CR]
	%1	"DFLT" ----- Default Logo is enabled "USER" ----- User is enabled "OFF" ----- Off is enabled
	Unacceptable	"?" [CR]

### 9.10.4 CR\_LOGOLOCK Command

Command	"CR_LOGOLOCK" [CR]	
Details	Get setting status of Logo Lock function	
Response	Acceptable	"000_%1" [CR]
	%1	"ON" ----- Logo Lock is ON "OFF" ----- Logo Lock is OFF
	Unacceptable	"Error Code" [CR]

### 9.10.5 CR\_RCODE Command

Command	"CR_RCODE" [CR]	
Details	Get currently selected Remote Control code	
Response	Acceptable	"000_%1" [CR]
	%1	"001" ----- Code1 "002" ----- Code2 : "007" ----- Code7 "008" ----- Code8
	Unacceptable	"?" [CR]

### 9.10.6 CR\_RSENS Command

Command	"CR_RSENS" [CR]	
Details	Get selected location of infrared remote receiver of remote control	
Response	Acceptable	"000_%1" [CR]
	%1	"BOTH" -----Select both front and back receiver of projector "FRONT" ---- Select only front receiver of projector "BACK" ----- Select only back receiver of projector
	Unacceptable	"?" [CR]

### 9.10.7 CR\_LANG Command

Command	"CR_LANG" [CR]	
Details	Get selected language	
Response	Acceptable	"000_%1" [CR]
	%1	"ENG" ----- English is selected "DEU" ----- German is selected "FRA" ----- French is selected "ITA" ----- Italian is selected "ESP" ----- Spanish is selected "POR" ----- Portuguese is selected "NED" ----- Dutch is selected "SVE" ----- Swedish is selected "CHI" ----- Chinese is selected "KOR" ----- Korean is selected "JPN" ----- Japanese is selected "RUS" ----- Russian is selected
	Unacceptable	"?" [CR]

### 9.10.8 CR\_ON-STA Command

Command	"CR_ON-STA" [CR]	
Details	Get Power ON Start setting status	
Response	Acceptable	"000_%1" [CR]
	%1	"ON" ----- Power ON Start is set to ON. "OFF" ----- Power ON Start is set to OFF.
	Unacceptable	"?" [CR]

### 9.10.9 CR\_P-MANE Command

Command	"CR_P-MANE" [CR]	
Details	Get setting status of Power management	
Response	Acceptable	"000_%1" [CR]
	%1	"OFF" ----- Power Management is disabled "READY" ----- Power Management is set to Ready "SHUTDOWN" -----Power Management is set to Shut Down mode
	Unacceptable	"?" [CR]

### 9.10.10 CR\_P-MANETIME Command

Command	"CR_P-MAETIME" [CR]	
Details	Get setting time for starting Power Management function	
Response	Acceptable	"000_%1" [CR]
	%1	"001 – 030" ----- 1 to 30 minutes
	Unacceptable	"?" [CR]

### 9.10.11 CR\_FANSPEED Command

Command	"CR_FANSPEED" [CR]	
Details	Get currently selected Fan Control Speed	
Response	Acceptable	"000_%1" [CR]
	%1	"MAX" ----- Max speed of Fan Control is selected "NOR" ----- Normal speed of Fan Control is selected
	Unacceptable	"?" [CR]

### 9.10.12 CR\_KEYDIS Command

Command	"CR_KEYDIS" [CR]	
Details	Get setting status of RC/KEY use limitation (valid or invalid)	
Response	Acceptable	"000_%1" [CR]
	%1	"NONE" ----- RC & KEY are valid "RC" ----- RC is invalid "KEY" ----- KEY is invalid
	Unacceptable	"?" [CR]

### 9.10.13 CR\_SHUTRCPROT Command

Command	"CR_SHUTRCPROT" [CR]	
Details	Get status if Shutter can be controlled by R/C	
Response	Acceptable	"000_%1" [CR]
	%1	"ON" ----- Shutter is not controllable by R/C "OFF" ----- Shutter is controllable by R/C
	Unacceptable	"?" [CR]

### 9.10.14 CR\_SHUTKEYPROT Command

Command	"CR_SHUTKEYPROT" [CR]	
Details	Get status if Shutter can be controlled by key on the top panel	
Response	Acceptable	"000_%1" [CR]
	%1	"ON" ----- Shutter is not controllable by key on the top panel "OFF" ----- Shutter is controllable by key on the top panel
	Unacceptable	"?" [CR]

**9.10.15 CR\_SHUTH Command**

Command	"CR_SHUTH" [CR]	
Details	Get time setting to start the shutter management	
Response	Acceptable	"000_%1" [CR]
	%1	"005" ----- 5 minutes "006" ----- 6 minutes : "179" ----- 179 minutes "180" ----- 180 minutes
	Unacceptable	"?" [CR]

**9.10.16 CR\_SECURITY Command**

Command	"CR_SECURITY" [CR]	
Details	Get ON/OFF setting status of Security on menu.	
Response	Acceptable	"000_%1" [CR]
	%1	"ON" ----- PJ is locked "OFF" ----- PJ is not locked.
	Unacceptable	"Error Code" [CR]

**9.10.17 CR\_PJLOCKNOW Command**

Command	"CR_PJLOCKNOW" [CR]	
Details	Get actual setting status of PIN code lock	
Response	Acceptable	"000_%1" [CR]
	%1	"LOCK" ----- PJ is locked PIN code lock is set to ON1/ON2 on the menu and PJ PIN code is not entered, therefore PJ is actually locked. "FREE" ----- PJ is unlocked (either A or B) A) PJ lock is set to OFF on the menu B) PJ lock is set to ON1/ON2 on the menu, but PIN code Lock mode is canceled because PJ PIN code is entered.
	Unacceptable	"Error Code" [CR]

**9.10.18 CR\_PJLOCMENU Command**

Command	"CR_PJLOCKMENU" [CR]	
Details	Get ON/OFF setting status of PIN code lock on menu	
Response	Acceptable	"000_%1" [CR]
	%1	"ON1" ----- PIN code lock ON 1 is set on the menu "ON2" ----- PIN code lock ON 2 is set on the menu "OFF" ----- PIN code lock OFF is set on the menu
	Unacceptable	"Error Code" [CR]

**9.10.19 CR\_FILH Command**

Command	"CR_FILH" [CR]	
Details	Get Filter used time	
Response	Acceptable	"000_%1" [CR]
	%1	"00000 - 99999"
	Unacceptable	"Error Code" [CR]

### 9.10.20 CR\_FILCOND Command

Command	"CR_FILCOND" [CR]	
Details	Get status of filter clog	
Response	Acceptable	"000_%1" [CR]
	%1	"CLOG" = Filter is clogged "WARN" = Filter is nearly clogged "CLEAN" = Filter is not clogged
	Unacceptable	"Error Code" [CR]

### 9.10.21 CR\_FILREPL Command

Command	"CR_FILREPL" [CR]	
Details	Get status of Filter cleaning / replacement time	
Response	Acceptable	"000_%1" [CR]
	%1	"1Y"-----Filter Exchange time is over value of Filter Message. "1N"--Filter Exchange time is not over value of Filter Message.
	Unacceptable	"Error Code" [CR]

### 9.10.22 CR\_FILTIMER Command

Command	"CR_FILTIMER" [CR]	
Details	Get time to display Filter cleaning / replacement warning on screen	
Response	Acceptable	"000_%1" [CR]
	%1	"0400" ----- Display message by 400h used. "0700" ----- Display message by 700h used. "1000" ----- Display message by 1000h used. "OFF" ----- Off(Warning display is not displayed)
	Unacceptable	"Error Code" [CR]

### 9.10.23 CR\_FILREMAIN Command

Command	"CR_FILREMAIN" [CR]	
Details	Get remaining number of usable Filter scroll	
Response	Acceptable	"000_%1" [CR]
	%1	"09" = Remaining number of usable Filter scroll : 9 times : "00" = Remaining number of usable Filter scroll : 0 time
	Unacceptable	"Error Code" [CR]

### 9.10.24 CR\_TESTPAT Command

Command	"CR_TESTPAT" [CR]	
Details	Get setting status of Test pattern	
Response	Acceptable	"000_%1" [CR]
	%1	"COLOR" ----- Color bar is displayed "GRAD1" ----- 16step(white→black) is displayed "GRAD2" ----- 16step(white←black) is displayed "GRAD3" ----- 16step(white↓black) is displayed "GRAD4" ----- 16step(white↑black) is displayed "WHITE" ----- All white is displayed "BLACK" ----- All black is displayed "CROSS" ----- Cross is displayed "OFF" ----- Test pattern display is not displayed
	Unacceptable	"Error Code" [CR]

## 9.11 Other Status Read Commands

### 9.11.1 CR\_STATUS Command

Command	"CR_STATUS" [CR]	
Details	Get operating status of Projector Same as "CR0" in basic command except error code follows it.	
Response	Acceptable	"000_%1" [CR]
	%1	"00" = Power ON "80" = Standby "40" = Countdown in process "20" = Cooling Down in process "10" = Power Failure "28" = Cooling Down in process due to abnormal temperature "88" = Standby after Cooling Down due to abnormal temperature "02" = Invalid RS-232C Command "24" = Power Save/Cooling Down in process "21" = Cooling Down in process after turned Off due to lamp failure "81" = Standby after Cooling Down due to lamp failure "2C" = Cooling Down in process after Power Off due to Shutter management "8C" = Standby after Cooling Down due to Shutter management
	Unacceptable	"Error Code" [CR]

### 9.11.2 CR\_SIGNAL Command

Command	"CR_SIGNAL" [CR]	
Details	Get status if there is any signal or not	
Response	Acceptable	"000_%1" [CR]
	%1	"ON" ----- There is signal "OFF" ----- There is no signal
	Unacceptable	"?" [CR]

### 9.11.3 CR\_VMUTE Command

Command	"CR_VMUTE" [CR]	
Details	Get Video mute setting status	
Response	Acceptable	"000_%1" [CR]
	%1	"ON" ----- Video mute is set to ON (Shutter Close). "OFF" ----- Video mute is set to OFF (Shutter Open).
	Unacceptable	"?" [CR]

### 9.11.4 CR\_FREEZE Command

Command	"CR_FREEZE" [CR]	
Details	Get Freeze setting status	
Response	Acceptable	"000_%1" [CR]
	%1	"ON" ----- Freeze is set to ON. "OFF" ----- Freeze is set to OFF.
	Unacceptable	"?" [CR]

### 9.11.5 CR\_P-TIMER Command

Command	"CR_P-TIMER" [CR]	
Details	Get Presentation Timer operating status	
Response	Acceptable	"000_%1" [CR]
	%1	"ON" ----- Presentation Timer is ongoing. "STOP" ----- Presentation Timer is paused. "OFF" ----- Presentation Timer is not active.
	Unacceptable	"?" [CR]

### 9.11.6 CR\_TEMPWARN Command

Command	"CR_TEMPWARN" [CR]	
Details	Get the information about the temperature inside the projector (close to the abnormal or in the abnormal status/in the safe temperature level/abnormal status is not detected). It is possible to get the information about more than one sensor all at once if it is applicable.	
Response	Acceptable	"000_%1" [CR]
	%1	"* _ *" Sensor 1 data comes first, and then one space, after that sensor 2 data is followed. Each data is as below: "W"--- in or close to the abnormal temp. (Warning Temp.) "S"--- in the safe level of temperature (Safe Temp.) "N"--- the given sensor does not detect abnormal temp.  e.g. "S_W" [CR] indicates that the temperature detected at Sensor 1 is in the safe level while Sensor 2 in the abnormal temperature.
	Unacceptable	"?" [CR]

**9.11.7 CR\_TEMPFAIL Command**

Command	"CR_TEMPFAIL" [CR]	
Details	Get the temperature inside the projector when the abnormal status occurs. It is possible to get the temperatures for more than one sensor all at once if it is applicable.	
Response	Acceptable	"000_%1" [CR]
	%1	<p>e.g. "_31.5F"[CR]                      _ indicates a space. When the temperature goes under 0, the first character is "-", not a space, as in "-05.5F".                      With more than one temperature sensors installed, projector returns the responses for each sensor in a row.</p> <p>e.g. "_31.5F_35.2S" [CR]                      The first data indicates sensor 1 data, then one space, and sensor 2 data is followed.                      Last character in each data indicates the sensor's status.                      In the abnormal temperature ----- "F"                      In the safe level of temperature ----- "S"                      Neither in or close to the abnormal temp. ----- "N"</p> <p>The second example above indicates that the temperature detected by sensor 1 is 31.5 which means in the abnormal temperature, and at sensor 2 is 32.5 degrees which is in the safe temperature.</p> <p>When the abnormal temperature status is not occurred the data should be "_00.0S".                      When the projector is reset, "_00.0S" is set. Every time abnormal temperature status is detected, it renews the data and returns it. It only returns the renewed data of the latest abnormal temperature and the previous data is cleared.</p>
	Unacceptable	"?" [CR]

**9.11.8 CR\_SERIALNO Command**

Command	"CR_SERIALNO" [CR]	
Details	Get value of the serial number. (For Dealer)	
Response	Acceptable	"000_%1" [CR]
	%1	Eight digits of alphanumeric characters
	Unacceptable	"?" [CR]

**9.11.9 CR\_SHUTCOND Command**

Command	"CR_SHUTCOND" [CR]	
Details	Get setting status of Shutter	
Response	Acceptable	"000_%1" [CR]
	%1	<p>"SAFE" ----- Shutter operation is normal.                      "FAIL" ----- Shutter operation is abnormal.</p>
	Unacceptable	"?" [CR]

## 9.12 HD-wireless Read Commands

### 9.12.1 CR\_HDWLMODE Command

Command	"CR_HDWLMODE"[CR]	
Details	Get communication mode with a radio transmitter. (Valid only when HD-wireless input is selected)	
Response	Acceptable	"000_%1" [CR]
	%1	"SINGLE"----- 1-1 mode is set "BROADCAST"----- 1-N mode is set
	Unacceptable	"Error Code" [CR]

### 9.12.2 CR\_HDWLAUTH Command

Command	"CR_HDWLAUTH"[CR]	
Details	Get status of the authentication between Tx-Rx. (Valid only when HD-wireless input is selected and Single mode is set)	
Response	Acceptable	"000_%1" [CR]
	%1	"CONNECT"-----Authentication is success "CONNECTING"-----Authentication in process "DISCONNECT"----- Authentication is failure
	Unacceptable	"Error Code" [CR]

### 9.12.3 CR\_HDWLINID Command

Command	"CR_HDWLINID" [CR]	
Details	Get the ID of the transmitters. (Valid only when HD-wireless input is selected and Broadcast mode is set)	
Response	Acceptable	"000_%1" [CR]
	%1	"*****" (Eight digits)---- ID of Tx * is shown in capitalized letter, from 0 - F.
	Unacceptable	"Error Code" [CR]

### 9.12.4 CR\_HDWLRECEPLV Command

Command	"CR_HDWLRECEPLV"[CR]																	
Details	Get status of the reception level of a radio beam (Valid only when HD-wireless input is selected)																	
Response	Acceptable	"000_%1" [CR]																
	%1	<table style="border: none; width: 100%;"> <tr> <td style="width: 150px;">"LV0"-----</td> <td style="text-align: right;">reception strength: High</td> </tr> <tr> <td>"LV1"-----</td> <td style="text-align: center;">↑</td> </tr> <tr> <td>"LV2"-----</td> <td style="text-align: center;"> </td> </tr> <tr> <td>"LV3"-----</td> <td style="text-align: center;"> </td> </tr> <tr> <td>"LV4"-----</td> <td style="text-align: center;"> </td> </tr> <tr> <td>"LV5"-----</td> <td style="text-align: center;"> </td> </tr> <tr> <td>"LV6"-----</td> <td style="text-align: center;"> </td> </tr> <tr> <td>"LV7"-----</td> <td style="text-align: right;">reception strength: Low</td> </tr> </table>	"LV0"-----	reception strength: High	"LV1"-----	↑	"LV2"-----		"LV3"-----		"LV4"-----		"LV5"-----		"LV6"-----		"LV7"-----	reception strength: Low
	"LV0"-----	reception strength: High																
	"LV1"-----	↑																
	"LV2"-----																	
	"LV3"-----																	
"LV4"-----																		
"LV5"-----																		
"LV6"-----																		
"LV7"-----	reception strength: Low																	
Unacceptable	"Error Code" [CR]																	
%1	"ON" ----- Freeze is set to ON. "OFF" ----- Freeze is set to OFF.																	
Unacceptable	"Error Code" [CR]																	

## 10. Command with Address Specification

### 10.1. Overview

- Commands with address are used to remote control more than one projector through RS-232C by a computer.
- The command with address is defined as a single command per line that starts with "A" and ends with carriage return (0x0D).
- When a projector receives carriage return (0x0D), it starts decoding.
- The address such as "A001" is prefixed to the Basic Serial Command or Expand Serial Command already mentioned.

e.g.) Functional Execution Command: "A001C05" [CR]

e.g.) Status Read Command: "A001CR0" [CR]

- Projector has the function to set up its own address in Service mode.

Initial setting value is "No.001"

Available range of the value is "001" to "999"

- It clears the data in the receive buffer in the following cases.
  - When receiving LF (0x0A) or EOF (0x1A)
  - When it takes more than one second to receive a single command.  
(Until receiving carriage return after the reception of the first data)
- It returns the response within 60ms.

### 10.2. Functional Execution Command with address

#### 10.2.1. Format

- 1) PC issues a command in the format below:

"A" **Address** "C" **Command** [CR]

or

"A" **Address** "CF\_" **Command** "\_" **Parameter** [CR]

Address: 3-digit number ("001" – "999")

Commands with "FFF" as the address are valid to all projectors.

Command: string (Refer to Basic and Expand Serial Command)

- 2) The only projector with the appropriate address decodes the received command, and when it is ready to receive the next command, it returns the response.

**[ACK] [CR]**: When receiving Functional Execution Command (0x06, 0x0D)

" – " **[CR]**: When the received data cannot be decoded

However, when the address is "FFF", the projector executes the function but does not return the response.

### 10.2.2. When the command pipelining is needed

When it needs command pipelining, the operation is the same as the remote control as below:

- 1) Sending-side system issues commands every 100ms
- 2) When receiving an applicable command, the function is executed repeatedly for 120ms.
- 3) When receiving the same command in a row within 120ms, the function is repeatedly executed for another 120ms from the moment of the second command reception.
- 4) When there is no incoming command after 120ms, the execution of pipelining is stopped.
- 5) When the projector receives other command within 120ms, the execution of pipelining is stopped.

## 10.3. Status Read Command with Address

### 10.3.1. Format

- 1) PC issues a command in the format as below:

**"A" Address "CR" Command [CR]**

or

**"A" Address "CR\_" Command [CR]**

Address: 3-digit number ("001" – "999")

Command: string (Refer to Basic and Expand Serial Commands)

The only projectors that have the address matching with the one in the received data decode the command, and it returns required data.

**Required Data [CR]**

Required Data: String (Refer to Basic Status Read Commands)

- 3) When the received data cannot be decoded, it returns "? " [CR]