

EXPAND SERIAL COMMAND FUNCTIONAL SPECIFICATIONS

PLC-XP100L

SANYO Electric Co., Ltd
Personal Mobile Group
DI Company
Projector Division

Contents

1 . Overview	8
2 . Serial Interface Specification.....	8
2.1 Transfer Specification	8
2.2 Connection	8
3 . Notes for communication.....	9
4 . Notation Convention.....	9
5 . Functional Execution Command Table.....	10
5.1 Image Command Table.....	10
5.2 PC Adjust Control Command Table.....	10
5.3 Input Control Command Table	10
5.4 Screen Control Command Table.....	11
5.5 Lamp Command Table	11
5.6 Setting Command Table.....	11
5.7 Other Command Table	11
6 . Status Read Command Table.....	12
6.1 Image Status Read Command Table.....	12
6.2 PC Adjust Status Read Command Table.....	12
6.3 Video Status Read Command Table	12
6.4 Input Status Read Command Table	13
6.5 Screen Status Read Command Table	13
6.6 Lamp Status Read Command Table.....	13
6.7 Setting Status Read Command Table.....	13
6.8 Other Status Read Command Table.....	14
7 . Error Code Table	14
8 . Functional Execution Command.....	15
8.1 Format.....	15
8.2 Transfer Example.....	15
8.3 Operation Requirements.....	15
8.4 Image Command.....	16
8.4.1 CF_ BRIGHT Command.....	16
8.4.2 CF_ CONT Command.....	16
8.4.3 CF_ COLOR Command.....	16
8.4.4 CF_ TINT Command.....	16
8.4.5 CF_ SHARP Command.....	17
8.4.6 CF_ GAMMA Command.....	17
8.4.7 CF_ WBAL- Command.....	17
8.4.8 CF_ COLTEMP Command	17
8.4.9 CF_ OFFSET- Command	18
8.4.10 CF_ NZRED Command	18

8.4.11	CF_PROGV Command	18
8.4.12	CF_IMAGE Command	19
8.4.13	CF_IMAGEADJ Command	19
8.4.14	CF_APCTRL Command	19
8.4.15	CF_COLMNSAV Command	20
8.4.16	CF_COLMNLD Command	20
8.5	PC Adjust Control Command	21
8.5.1	CF_FSYNC Command	21
8.5.2	CF_TDOTS Command	21
8.5.3	CF_CLPPHASE Command	21
8.5.4	CF_H-POS Command	21
8.5.5	CF_V-POS Command	22
8.5.6	CF_DDOTS Command	22
8.5.7	CF_DLINE Command	22
8.5.8	CF_SETPCADJ Command	22
8.5.9	CF_ORGMODE Command	23
8.5.10	CF_PCSTORE Command	23
8.5.11	CF_PCMODEFREE Command	24
8.6	Input Control Command	25
8.6.1	CF_INPUT Command	25
8.6.2	CF_SOURCE Command	25
8.6.3	CF_INPUT 1 Command	26
8.6.4	CF_INPUT 2 Command	26
8.6.5	CF_INPUT 3 Command	26
8.6.6	CF_INPUT 4 Command	26
8.6.7	CF_SYSTEM Command	26
8.7	Screen Control Command	28
8.7.1	CF_SCREEN Command	28
8.7.2	CF_VSCALE Command	28
8.7.3	CF_VPOS Command	28
8.7.4	CF_HSCALE Command	29
8.7.5	CF_HPOS Command	29
8.7.6	CF_DZCENT Command	29
8.7.7	CF_KEYSTONE Command	30
8.7.8	CF_KYSTNMODE Command	30
8.8	Lamp Command	31
8.8.1	CF_LAMPH Command	31
8.8.2	CF_LAMPMODE Command	31
8.9	Setting Command	32
8.9.1	CF_BACKGND Command	32

8.9.2	CF_DISP Command	32
8.9.3	CF_LOGO Command	32
8.9.4	CF_CEIL Command	33
8.9.5	CF_REAR Command	33
8.9.6	CF_RCODE Command	33
8.9.7	CF_RSENS Command	33
8.9.8	CF_LANG Command	34
8.9.9	CF_ON-STA Command	34
8.9.10	CF_P-MANE Command	34
8.9.11	CF_P-MANETIME Command	35
8.9.12	CF_FANSPEED Command	35
8.9.13	CF_KEYDIS Command	35
8.9.14	CF_FDEFAULT Command	35
8.9.15	CF_PJPINCODE Command	36
8.9.16	CF_TESTPAT Command	36
8.9.17	CF_FILH Command	36
8.9.18	CF_FILTIMER Command	36
8.9.19	CF_FILCTL Command	37
8.9.20	CF_FILSCRL Command	37
8.9.21	CF_POINTER Command	37
8.10	Other Commands	37
8.10.1	CF_KEYEMU Command	37
8.10.2	CF_MENU Command	37
8.10.3	CF_POWER Command	38
8.10.4	CF_FREEZE Command	38
9.	Status Read Command	39
9.1	Format	39
9.2	Transfer Example	39
9.3	Operation Condition	39
9.4	Image Status Read Command	39
9.4.1	CR_BRIGHT Command	39
9.4.2	CR_CONT Command	39
9.4.3	CR_COLOR Command	39
9.4.4	CR_TINT Command	40
9.4.5	CR_SHARP Command	40
9.4.6	CR_GAMMA Command	40
9.4.7	CR_WBAL-R Command	40
9.4.8	CR_WBAL-G Command	40
9.4.9	CR_WBAL-B Command	40
9.4.10	CR_COLTEMP Command	41

9.4.11	CR_OFFSET-R Command	41
9.4.12	CR_OFFSET-G Command	41
9.4.13	CR_OFFSET-B Command	41
9.4.14	CR_NZRED Command	41
9.4.15	CR_PROGV Command	41
9.4.16	CR_IMAGE Command	42
9.4.17	CR_IMGGMD Command	42
9.4.18	CR_APCTRL Command	42
9.5	PC Adjust Status Read Command	43
9.5.1	CR_FSYNC Command	43
9.5.2	CR_TDOTS Command	43
9.5.3	CR_CLPPHASE Command	43
9.5.4	CR_H-POS Command	43
9.5.5	CR_V-POS Command	43
9.5.6	CR_DDOTS Command	44
9.5.7	CR_DLINE Command	44
9.5.8	CR_ORGMODE Command	44
9.5.9	CR_PCSTORE Command	45
9.5.10	CR_SETPCADJ Command	45
9.6	Video Status Read Command	46
9.6.1	CR_SERSYS Command	46
9.7	Input Read Command	46
9.7.1	CR_INPUT Command	46
9.7.2	CR_SOURCE Command	46
9.7.3	CR_SRCINP1 Command	46
9.7.4	CR_SRCINP2 Command	47
9.7.5	CR_SRCINP3 Command	47
9.7.6	CR_SRCINP4 Command	47
9.7.7	CR_SYSTEM Command	47
9.7.8	CR_SYSLIST Command	48
9.7.9	CR_MODELIST Command	49
9.7.10	CR_HMSLOT Command	49
9.7.11	CR_NMSLOT1 Command	49
9.7.12	CR_NMSLOT2 Command	50
9.7.13	CR_NMSLOT3 Command	50
9.7.14	CR_NMSLOT4 Command	50
9.7.15	CR_IDSLOT1 Command	50
9.7.16	CR_IDSLOT2 Command	50
9.7.17	CR_IDSLOT3 Command	51
9.7.18	CR_IDSLOT4 Command	51

9.8 Screen Status Read Command	51
9.8.1 CR_SCREEN Command	51
9.8.2 CR_VSCALE Command	51
9.8.3 CR_VPOS Command	51
9.8.4 CR_HSCALE Command	52
9.8.5 CR_HPOS Command	52
9.8.6 CR_KYSTNMODE Command	52
9.9 Lamp Status Read Command	53
9.9.1 CR_LAMPREPL Command	53
9.9.2 CR_LAMPH Command	53
9.9.3 CR_LAMPCORRESPH Command	53
9.9.4 CR_LAMPMODE Command	53
9.9.5 CR_LAMPSTS Command	53
9.9.6 CR_PROJH Command	54
9.9.7 CR_HMLAMP Command	54
9.10 Setting Status Read Command	55
9.10.1 CR_BACKGND Command	55
9.10.2 CR_DISP Command	55
9.10.3 CR_LOGO Command	55
9.10.4 CR_LOGOLOCK Command	55
9.10.5 CR_CEIL Command	55
9.10.6 CR_REAR Command	56
9.10.7 CR_RCODE Command	56
9.10.8 CR_RSENS Command	56
9.10.9 CR_RTYPE Command	56
9.10.10 CR_LANG Command	56
9.10.11 CR_ON-STA Command	57
9.10.12 CR_P-MANE Command	57
9.10.13 CR_P-MANETIME Command	57
9.10.14 CR_FANSPEED Command	57
9.10.15 CR_KEYDIS Command	57
9.10.16 CR_SECURITY Command	58
9.10.17 CR_PJLOCKNOW Command	58
9.10.18 CR_PJLOCKMENU Command	58
9.10.19 CR_TESTPAT Command	58
9.10.20 CR_FILH Command	59
9.10.21 CR_FILCOND Command	59
9.10.22 CR_FILREPL Command	59
9.10.23 CR_FILTIMER Command	59
9.10.24 CR_FILREMAIN Command	59

9.10.25 CR_POINTER Command	59
9.11 Other Status Read Commands	60
9.11.1 CR_STATUS Command	60
9.11.2 CR_PRESSURE Command	60
9.11.3 CR_SIGNAL Command	60
9.11.4 CR_VMUTE Command	60
9.11.5 CR_FREEZE Command	61
9.11.6 CR_ALLPFAIL Command	61
9.11.7 CR_HMPFAIL Command	61
9.11.8 CR_PFAIL01 Command	61
9.11.9 CR_PFAIL02 Command	62
9.11.10 CR_PFAIL03 Command	62
9.11.11 CR_PFAIL04 Command	62
9.11.12 CR_PFAIL05 Command	62
9.11.13 CR_PFAIL06 Command	62
9.11.14 CR_PFAIL07 Command	63
9.11.15 CR_PFAIL08 Command	63
9.11.16 CR_PFAIL09 Command	63
9.11.17 CR_PFAIL10 Command	63
9.11.18 CR_PFAIL11 Command	63
9.11.19 CR_PFAIL12 Command	64
9.11.20 CR_PFAIL13 Command	64
9.11.21 CR_PFAIL14 Command	64
9.11.22 CR_PFAIL15Command	64
9.11.23 CR_PFAIL16 Command	64
9.11.24 CR_PFAIL17 Command	65
9.11.25 CR_PFAIL18 Command	65
9.11.26 CR_PFAIL19 Command	65
9.11.27 CR_PFAIL20 Command	65
9.11.28 CR_PFAIL21 Command	65
9.11.29 CR_PFAIL22 Command	66
9.11.30 CR_PFAIL23 Command	66
9.11.31 CR_PFAIL24 Command	66
9.11.32 CR_PFAIL25 Command	66
9.11.33 CR_PFAIL26 Command	66
9.11.34 CR_PFAIL27 Command	67
9.11.35 CR_TEMPFAIL Command	67
9.11.36 CR_TEMP Command	67

PLC-XP100L Expand Serial Command Functional Specifications

1 . Overview

- This Functional Specification defines communication with PJ-Net organizer for PLC-XP100L.
- Supporting Firmware Ver. 1.x of the projector.
- Commands in this document are to communicate with PJ-Net organizer, but most commands are used to control a projector remotely from a computer with RS-232C. Therefore commands in this document are defined as Expand Serial Commands.

2 . Serial Interface Specification

2.1 Transfer Specification

Item	Specification
Synchronous System	Asynchronous
Transmission Speed	9600 / 19200
Data Length	8 bits
Parity	N/A
Stop Bit	1
Flow Control	N/A

Note1) Transmission Speed: initial setting value is 19200

Note2) Transmission Speed can be changed in Service mode.

2.2 Connection

Dedicated serial cables that come with the projector must be used for the connection between a computer and a projector.

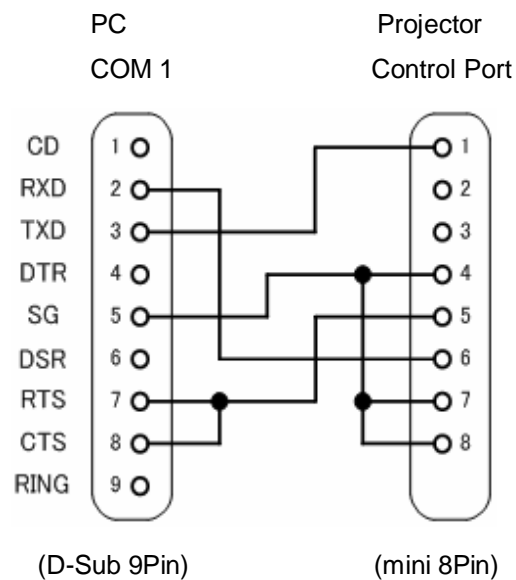

3 . Notes for communication

- Expand Serial Command is defined as a single command per line that starts with "C" and ends with carriage return (0x0D).
- There are two types of commands; Functional Execution Commands and Status Read Command.
 - Example of Functional Execution Command: "CF_BRIGHT_032" [CR]
 - Example of Status Read Command: "CR_BRIGHT" [CR]

Note) "_" means a space

- When it takes more than a second to receive a single command, it is not executed.
When it takes more than a second to receive carriage return (0x0D) since the reception of the first data "C", it clears the information of the receive buffer.
- When the command pipelining, allow the interval time of no less than 100ms after receiving return value.

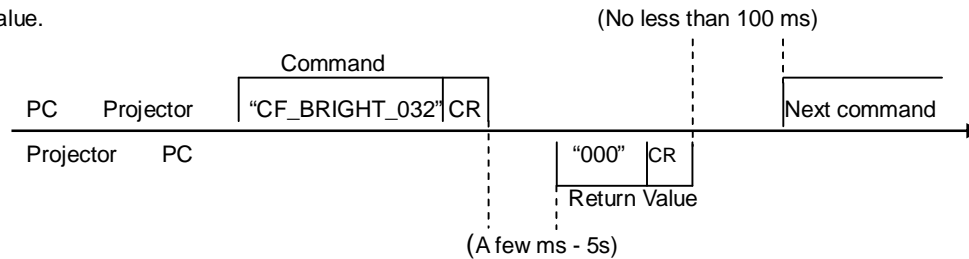

- Do not send another command before the reception of the return value; the operation by the command is not ensured.
However this is not the case when no response is returned after more than 5 seconds.
- It takes about 5 seconds for internal initialization after plugging in AC power. During this time, it cannot process commands. Do not issue any command.

4 . Notation Convention

- Data from a controller to a projector is represented as COMMAND, and data from a projector to a controller in response to the incoming command is represented as RESPONSE.
- [CR]: Carriage Return Code
Carriage Return code is added to the end of the command.
Response is also followed by carriage return code.
- _ : Space Code
Space Code is represented as (_).
- %1: Parameter included in Command
When there are more than one parameter, they are defined as %2, %3...
- %%: Error Code returned from a projector
Acceptable: "000".
Unacceptable: See [7. Error Code Table].

5 . Functional Execution Command Table

5.1 Image Command Table

Execute command	Item
CF_BRIGHT_%1 [CR]	Set value of Brightness
CF_CONT_%1 [CR]	Set value of Contrast
CF_COLOR_%1 [CR]	Set value of Color
CF_TINT_%1 [CR]	Set value of Tint
CF_SHARP_%1 [CR]	Set value of Sharpness
CF_GAMMA_%1 [CR]	Set value of Gamma
CF_WBAL-R_%1 [CR]	Set Red value of White Balance
CF_WBAL-G_%1 [CR]	Set Green value of White Balance
CF_WBAL-B_%1 [CR]	Set Blue value of White Balance
CF_COLTEMP_%1 [CR]	Set level of Color Temperature
CF_OFFSET-R_%1 [CR]	Set Red value of Offset
CF_OFFSET-G_%1 [CR]	Set Green value of Offset
CF_OFFSET-B_%1 [CR]	Set Blue value of Offset
CF_NZRED_%1 [CR]	Set ON/OFF of Noise reduction
CF_PROGV_%1 [CR]	Set mode of Progressive scan
CF_IMAGE_%1 [CR]	Set Image mode
CF_IMAGEADJ_%1 [CR]	Set Store/Reset of values in Image Adjustment
CF_APCTRL_%1 [CR]	Set level of Auto Picture Control
CF_COLMNSAV_%1 [CR]	Set area to store current values of Color Management
CF_COLMNLD_%1 [CR]	Set area to load values of Color Management

5.2 PC Adjust Control Command Table

Execute command	Item
CF_FSYNC_%1 [CR]	Set value of Fine Sync
CF_TDOTS_%1 [CR]	Set value of Total Dots
CF_CLPPHASE_%1 [CR]	Set value of Clamp Phase
CF_CLPWIDTH_%1 [CR]	Set value of Clamp Width
CF_H-POS_%1 [CR]	Set value of Horizontal Position
CF_V-POS_%1 [CR]	Set value of Vertical Position
CF_DDOTS_%1 [CR]	Set value of Display Dots
CF_DLINE_%1 [CR]	Set value of Display Line
CF_SETPCADJ_%1 [CR]	Apply values set in PC Adjust menu to screen image
CF_ORGMODE_%1 [CR]	Specify the original signal for PC mode
CF_PCSTORE_%1 [CR]	Store current setting values in PC Adjust menu to Mode %1
CF_PCMODEFREE_%1 [CR]	Delete the values registered in Mode %1 and return it to Free status.

5.3 Input Control Command Table

Execute command	Item
CF_INPUT_%1 [CR]	Select Input
CF_SOURCE_%1 [CR]	Select Source of selected Input
CF_INPUT1_%1 [CR]	Select Input1 and also set input source to %1
CF_INPUT2_%1 [CR]	Select Input2 and also set input source to %1
CF_INPUT3_%1 [CR]	Select Input3 and also set input source to %1
CF_INPUT4_%1 [CR]	Select Input4 and also set input source to %1
CF_SYSTEM_%1 [CR]	Select System of curretnly selected Input

5.4 Screen Control Command Table

Execute command	Item
CF_SCREEN_%1 [CR]	Select Screen size
CF_VSCALE_%1[CR]	Set V Scale
CF_VPOS_%1[CR]	Set V Position
CF_HSCALE_%1[CR]	Set H Scale
CF_HPOS_%1[CR]	Set H Position
CF_DZCENT_%1 [CR]	Cancel Digital Zoom mode
CF_KEystone_%1 [CR]	Set Keystone correction
CF_KYSTNMODE_%1 [CR]	Set Keystone store mode

5.5 Lamp Command Table

Execute command	Item
CF_LAMPH_%1 [CR]	Reset total running time for each lamp
CF_LAMPMODE_%1 [CR]	Select Lamp mode

5.6 Setting Command Table

Execute command	Item
CF_BACKGND_%1[CR]	Select screen for no signal
CF_DISP_%1 [CR]	Set ON/OFF of On Screen Display
CF_LOGO_%1 [CR]	Set PIN code and mode for Logo
CF_CEIL_%1 [CR]	Set ON/OFF of Ceiling
CF_REAR_%1 [CR]	Set ON/OFF of Rear
CF_RCODE_%1 [CR]	Select Remote Control Code
CF_RSENS_%1 [CR]	Select location of infrared remote receiver of remote control
CF_LANG_%1 [CR]	Select language for OSD
CF_ON-STA_%1 [CR]	Set ON/OFF of Power ON Start
CF_P-MANE_%1 [CR]	Set Power Management function
CF_P-MANETIME_%1 [CR]	Set time of Power Management
CF_FANSPEED_%1 [CR]	Set level of Fan Speed
CF_KEYDIS_%1 [CR]	Prohibit RC/KEY control
CF_FDEFAULT_%1 [CR]	Reset to Factory Default settings
CF_PJPINCODE_%1[CR]	Enter PJ PIN code to cancel PJ lock
CF_TESTPAT_%1[CR]	Set Test pattern display function
CF_FILH_%1[CR]	Reset Filter used time
CF_FILTIMER_%1[CR]	Set time to display Filter cleaning / replacement warning on screen
CF_FILCTL_%1[CR]	Execute operation of scroll of filter
CF_FILSCRL_%1[CR]	Reset Filter scroll counter
CF_POINTER_%1[CR]	Set Pointer function

5.7 Other Command Table

Execute command	Item
CF_KEYEMU_%1 [CR]	The same operation as RC/Control Key
CF_MENU_%1 [CR]	Set ON/OFF of Menu
CF_POWER_%1 [CR]	Set ON/OFF of Power
CF_FREEZE_%1 [CR]	Set ON/OFF of Freeze

6 . Status Read Command Table

6.1 Image Status Read Command Table

Status Read command	Item
CR_BRIGHT [CR]	Get value of Brightness
CR_CONT [CR]	Get value of Contrast
CR_COLOR [CR]	Get value of Color
CR_TINT [CR]	Get value of Tint
CR_SHARP [CR]	Get value of Sharpness
CR_GAMMA [CR]	Get value of Gamma
CR_WBAL-R [CR]	Get Red value of White Balance
CR_WBAL-G [CR]	Get Green value of White Balance
CR_WBAL-B [CR]	Get Blue value of White Balance
CR_COLTEMP [CR]	Get value of Color temperature
CR_OFFSET-R[CR]	Get Offset Red
CR_OFFSET-G[CR]	Get Offset Green
CR_OFFSET-B[CR]	Get Offset Blue
CR_NZRED [CR]	Get setting status of Noise reduction
CR_PROGV [CR]	Get setting status of Progressive scan
CR_IMAGE [CR]	Get Selected Image status
CR_IMGGMD [CR]	Get setting value of Image Gamma
CR_APCTRL [CR]	Get setting status of Auto Picture Control

6.2 PC Adjust Status Read Command Table

Status Read command	Item
CR_FSYNC [CR]	Get setting value of Fine Sync
CR_TDOTS [CR]	Get setting value of Total Dots
CR_CLPPHASE [CR]	Get setting value of Clamp phase
CR_CLPWIDTH [CR]	Get setting value of Clamp width
CR_H-POS [CR]	Get setting value of Horizontal Position
CR_V-POS [CR]	Get setting value of Vertical Position
CR_DDOTS [CR]	Get setting value of Display Dots
CR_DLINE [CR]	Get setting value of Display Line
CR_ORGMODE [CR]	Get the original signal for PC-Adjusted mode
CR_PCSTORE [CR]	Get status Free/ Stored for PC Adj. mode 1-10
CR_SETPCADJ [CR]	Get currently displayed PC signal in system

6.3 Video Status Read Command Table

Status Read command	Item
CR_SERSYS [CR]	Get currently selected signal. In Auto mode, it returns a result by Auto detection.

6.4 Input Status Read Command Table

Status Read command	Item
CR_INPUT [CR]	Get selected Input
CR_SOURCE [CR]	Get selected Source
CR_SRCINP1 [CR]	Get selected source for Input 1
CR_SRCINP2 [CR]	Get selected source for Input 2
CR_SRCINP3 [CR]	Get selected source for Input 3
CR_SRCINP4 [CR]	Get selected source for Input 4
CR_SYSTEM [CR]	Get selected system in current Input mode
CR_SYSLIST [CR]	Get possible system list
CR_MODELIST [CR]	Get possible mode list
CR_HMSLOT [CR]	Get total number of Inputs
CR_NMSLOT1 [CR]	Get terminal information of Input1.
CR_NMSLOT2[CR]	Get terminal information of Input2.
CR_NMSLOT3[CR]	Get terminal information of Input3
CR_NMSLOT4[CR]	Get terminal information of Input4.
CR_IDSLOT1[CR]	Get ID information of Input1
CR_IDSLOT2[CR]	Get ID information of Input2
CR_IDSLOT3[CR]	Get ID information of Input3
CR_IDSLOT4[CR]	Get ID information of Input4

6.5 Screen Status Read Command Table

Status Read command	Item
CR_SCREEN [CR]	Get selected screen size
CR_VSCALE[CR]	Get setting status of V Scale
CR_VPOS[CR]	Get setting status of V Position
CR_HSCALE[CR]	Get setting status of H Scale
CR_HPOS[CR]	Get setting status of H Position
CR_KYSTNMODE[CR]	Get selected Keystone store mode

6.6 Lamp Status Read Command Table

Status Read command	Item
CR_LAMPREPL [CR]	Get information of Lamp replacement time
CR_LAMPH [CR]	Get information of actual Lamp running time
CR_LAMPCORRESPH [CR]	Get lamp running time multiplied by a coefficient
CR_LAMPMODE [CR]	Get selected Lamp mode
CR_PROJH [CR]	Get total running time of projector

6.7 Setting Status Read Command Table

Status Read command	Item
CR_BACKGND [CR]	Get setting status of Screen for no signal
CR_DISP [CR]	Get setting status of Display
CR_LOGO [CR]	Get setting status of Logo
CR_LOGOLOCK[CR]	Get setting status of Logo Lock
CR_CEIL [CR]	Get setting status of Ceiling
CR_REAR [CR]	Get setting status of Rear
CR_RCODE [CR]	Get selected Remote Control code
CR_RSNS [CR]	Get selected location of infrared remote receiver of remote control
CR_RTYPE [CR]	Get supported Remote Control type (IR/RF)
CR_LANG [CR]	Get selected language
CR_ON-STA [CR]	Get ON Start setting status
CR_P-MANE [CR]	Get Power management setting status
CR_P-MANETIME [CR]	Get setting time for Power Management
CR_FANSPEED [CR]	Get selected Fan Control Speed

CR_KEYDIS [CR]	Get RC/KEY prohibited status
CR_SECURITY [CR]	Get setting status of Security
CR_PJLOCKNOW [CR]	Get setting status of current PJ Lock
CR_PJLOCKMENU [CR]	Get PJ Lock setting status on the menu
CR_TESTPAT[CR]	Get setting status of Test pattern
CR_FILH[CR]	Get Filter used time
CR_FILCOND[CR]	Get status of filter clog
CR_FILREPL[CR]	Get status of Filter cleaning / replacement time
CR_FILTIMER[CR]	Get time to display Filter cleaning / replacement warning on screen
CR_FILREMAIN[CR]	Get remaining number of usable Filter scroll
CR_POINTER[CR]	Get setting status of Pointer

6.8 Other Status Read Command Table

Status Read command	Item
CR_STATUS [CR]	Get operating status of Projector
CR_PRESSURE [CR]	Get air pressure information.
CR_SIGNAL [CR]	Get status of signal existence
CR_VMUTE [CR]	Get setting status of No show
CR_FREEZE [CR]	Get setting status of Freeze
CR_ALLPFAIL [CR]	Get all information of Power Failure
CR_HMPFAIL [CR]	Get total number of detectable Power Failure
CR_PFAIL01 [CR]	Get Item name of Power Failure No.01 and error status
CR_PFAIL02 [CR]	Get Item name of Power Failure No.02 and error status
⋮	⋮
CR_PFAIL50 [CR]	Get Item name of Power Failure No.50 and error status
CR_TEMPFAIL [CR]	Get temperature when sensors approach abnormal temperature
CR_TEMP [CR]	Get current temperature

7 . Error Code Table

Error Code	Contents
?	-When the received data cannot be decoded -Parameter designation error (wrong digit number, including invalid value, etc.)
000	Normal reception (This is “Not” error)
102	Directly specified value or values are out of range. (Not reflected)
103	Command mismatched to Hardware (the command is for Optional function which is not implemented)
201	Incremented or decremented value or values are beyond upper or lower limits.
301	Not executable due to screen capturing in process. Prompting reissue of the command after a while.
402	Not executable due to PIN code in operation. Prompting reissue of the command after a while.
101	Error not applicable to above errors

8 . Functional Execution Command

8.1 Format

1) PC issues commands in format as below:

Pattern1: "CF_ **COMMAND**" [CR]

Pattern2: "CF_ **COMMAND** _" %1 [CR]

CF_: Header

COMMAND: String

%1: Parameter (String)

_: Space (To separate COMMAND and Parameter)

2) The projector decodes the received command and when it is ready to receive the next command, it returns the response.

"000" [CR]: (0x06,0x0D) When receiving Functional Execution Command

"nnn" [CR]: Except "000", when it is unable to execute command for any specific reason.

See Error Code Table for details

3) When the received data cannot be decoded, the projector returns "?" [CR]

8.2 Transfer Example

When setting projector's total dots to 1344 by Expand Serial command

PC → PJ: "CF_TDOTS_1344" [CR]

PC → PJ: "000" [CR] ----- Acceptable

8.3 Operation Requirements

Functional Execution Command is limited when the projector status is as below.

However, Status Read Command is still effective under following conditions.

Projector Status	Available Functional Execution Command
Standby Mode	C00: Power ON CF POWER ON
Countdown in process	C00: Power ON CF POWER ON (Terminates Count Down)
Cooling Down in process	N/A
Cooling Down due to Abnormal Temperature	N/A
Abnormal Temperature	N/A
Power Failure (60 seconds after Power failure occurred)	N/A
Abnormal Filter	N/A
Power-Save Cooling Down in process	N/A
Cooling Down in process due to Shutter management	N/A
Power Save in process	C00: Power ON C01: Power OFF CF POWER ON CF POWER OFF

Note) When projector receives another command in the above status, it returns error code which shows the status.

8.4 Image Command

8.4.1 CF_BRIGHT Command

Command	"CF_BRIGHT_%1" [CR]	
%1	"000-063"----- Directly specify setting value of Brightness "UP"----- Increment setting value of Brightness by 1 "DN"----- Decrement setting value of Brightness by 1	
Details	Set user controlled value of Brightness (Available only in the normal Power ON status) The value set by this command will not be stored in the projector's memory. Therefore, when the power is turned to ALL OFF status, the value returns to the original setting. (It is stored in Standby mode.)	
Response	Acceptable	"000" [CR]
	Unacceptable	"Error Code" [CR]

8.4.2 CF_CONT Command

Command	"CF_CONT_%1" [CR]	
%1	"000-063"----- Directly specify setting value of Contrast "UP"----- Increment setting value of Contrast by 1 "DN"----- Decrement setting value of Contrast by 1	
Details	Set user controlled value of Contrast (Available only in the normal Power ON status) The value set by this command will not be stored in the projector. Therefore, when the power is turned to ALL OFF status, the value returns to the original setting. (It is stored in Standby mode.)	
Response	Acceptable	"000" [CR]
	Unacceptable	"Error Code" [CR]

8.4.3 CF_COLOR Command

Command	"CF_COLOR_%1" [CR]	
%1	"000-063"----- Directly specify setting value of Color "UP"----- Increment setting value of Color by 1 "DN"----- Decrement setting value of Color by 1	
Details	Set user controlled value of Color (Available only in the normal Power ON status) The value set by this command will not be stored in the projector's memory. Therefore, when the power is turned to ALL OFF status, the value returns to the original setting. (It is stored in Standby mode.)	
Response	Acceptable	"000" [CR]
	Unacceptable	"Error Code" [CR]

8.4.4 CF_TINT Command

Command	"CF_TINT_%1" [CR]	
%1	"000-063"----- Directly specify setting value of Tint "UP"----- Increment setting value of Tint by 1 "DN"----- Decrement setting value of Tint by 1	
Details	Set Tint value (Available only in the normal Power ON status) The value set by this command will not be saved to the projector's memory. Therefore, when the power is turned to ALL OFF status, the value returns to the original setting. (It is stored in Standby mode.)	
Response	Acceptable	"000" [CR]
	Unacceptable	"Error Code" [CR]

8.4.5 CF_SHARP Command

Command	"CF_SHARP_%1" [CR]	
%1	"000-031"----- Directly specify setting value of Sharpness "UP"----- Increment setting value of Sharpness by 1 "DN"----- Decrement setting value of Sharpness by 1	
Details	Set user controlled value of Sharpness (Available only in the normal Power ON status) The value set by this command will not be stored in the projector's memory. Therefore, when the power is turned to ALL OFF status, the value returns to the original setting. (It is stored in Standby mode.)	
Response	Acceptable	"000" [CR]
	Unacceptable	"Error Code" [CR]

8.4.6 CF_GAMMA Command

Command	"CF_GAMMA_%1" [CR]	
%1	"000-015"----- Directly specify setting value of Gamma "UP"----- Increment setting value of Gamma by 1 "DN"----- Decrement setting value of Gamma by 1	
Details	Set user controlled value of Gamma (Available only in the normal Power ON status) The value set by this command will not be stored in the projector's memory. Therefore, when the power is turned to ALL OFF status, the value returns to the original setting. (It is stored in Standby mode.)	
Response	Acceptable	"000" [CR]
	Unacceptable	"Error Code" [CR]

8.4.7 CF_WBAL- Command

Command	"CF_WBAL-%1_%2" [CR]	
%1	"R" ----- RED "G" ----- GREEN "B" ----- BLUE	
%2	"000-063"----- Directly specify value of Color selected in %1 of White Balance. "UP"----- Increment setting value of Color specified in %1 of White Balance by 1 "DN"----- Decrement setting value of Color specified in %1 of White Balance by 1	
Details	Set value of Color specified in %1 of White Balance (Available only in the normal Power ON status) The value set by this command will not be stored in the projector's memory. Therefore, when the power is turned to ALL OFF status, the value returns to the original setting. (It is stored in Standby mode.)	
Response	Acceptable	"000" [CR]
	Unacceptable	"Error Code"[CR]

8.4.8 CF_COLTEMP Command

Command	"CF_COLTEMP_%1" [CR]	
%1	"000" ----- Xlow "001" ----- Low "002" ----- Mid "003" ----- High	

Details	Set Color Temperature (Available only in the normal Power ON status) The value set by this command will not be stored in the projector's memory. Therefore, when the power is turned to ALL OFF status, the value returns to the original setting. (It is stored in Standby mode.)	
Response	Acceptable	"000" [CR]
	Unacceptable	"Error Code" [CR]

8.4.9 CF_OFFSET- Command

Command	"CF_OFFSET-%1_%2" [CR]	
%1	"R" ----- RED "G" ----- GREEN "B" ----- BLUE	
%2	"000-063"----- Directly specify value of Color selected in %1 of Offset. "UP"----- Increment setting value of Color specified in %1 of Offset by 1 "DN"----- Decrement setting value of Color specified in %1 of Offset by 1	
Details	Set value of Color specified in %1 of Offset (Available only in the normal Power ON status) The value set by this command will not be stored in the projector's memory. Therefore, when the power is turned to ALL OFF status, the value returns to the original setting. (It is stored in Standby mode.)	
Response	Acceptable	"000" [CR]
	Unacceptable	"Error Code"[CR]

8.4.10 CF_NZRED Command

Command	"CF_NZRED_%1" [CR]	
%1	"OFF" ----- Cancel Noise Reduction "ON" ----- Set Noise Reduction "UP" ----- Toggle between ON and OFF. (On→OFF→On→...) "DN" ----- Toggle between ON and OFF. (On→OFF→On→...) **"UP" and "DN" are exactly same operation.	
Details	Set Noise Reduction level (Available only in the normal Power ON status) The value set by this command will not be stored in the projector's memory. Therefore, when the power is turned to ALL OFF status, the value returns to the original setting. (It returns to the original setting in Standby mode as well.)	
Response	Acceptable	"000" [CR]
	Unacceptable	"Error Code" [CR]

8.4.11 CF_PROGV Command

Command	"CF_PROGV_%1" [CR]	
%1	"ON" ----- Set Progressive scan to On. "FILM" ----- Set Progressive scan to Film. "OFF" ----- Set Progressive scan to OFF. "UP" ----- Switch setting forward direction (OFF→ON→FILM→OFF) "DN" ----- Switch setting backward direction (OFF→FILM→ON→OFF)	
Details	Set Progressive scan mode. (Available only in the normal Power ON status) The value set by this command will not be stored in the projector's memory. Therefore, when the power is turned to ALL OFF status, the value returns to the original setting. (It is stored in Standby mode.)	
Response	Acceptable	"000" [CR]
	Unacceptable	"Error Code" [CR]

8.4.12 CF_IMAGE Command

Command	"CF_IMAGE_%1" [CR]	
%1	<p>"STAND" ----- Standard(Image adjust value is set to factory default for Still Image)</p> <p>"REAL"----- Real (Fixed value to display graphic image with natural tone)</p> <p>"CINEMA"----- Cinema (Fixed value to focus on tone reproduction for movie)</p> <p>"CUSTOM1" ----- Image1 (the value adjusted and stored by user)</p> <p>"CUSTOM2" ----- Image2 (the value adjusted and stored by user)</p> <p>"CUSTOM3" ----- Image3 (the value adjusted and stored by user)</p> <p>"CUSTOM4" ----- Image4 (the value adjusted and stored by user)</p> <p>"CUSTOM5" ----- Image5 (the value adjusted and stored by user)</p> <p>"CUSTOM6" ----- Image6 (the value adjusted and stored by user)</p> <p>"CUSTOM7" ----- Image7 (the value adjusted and stored by user)</p> <p>"CUSTOM8" ----- Image8 (the value adjusted and stored by user)</p> <p>"CUSTOM9" ----- Image9 (the value adjusted and stored by user)</p> <p>"CUSTOM10" ----- Image10 (the value adjusted and stored by user)</p>	
Details	<p>Select Image Mode (Available only in the normal Power ON status)</p> <p>Parameter "CUSTOM1" to "CUSTOM10" corresponds to "Image1" to "Image10" displayed in projector OSD menu on selecting Image.</p> <p>The value set by this command is stored in EEPROM so that the setting can remain effective even after the power is turned to ALL OFF status.</p>	
Response	Acceptable	"000" [CR]
	Unacceptable	"Error Code" [CR]

8.4.13 CF_IMAGEADJ Command

Command	"CF_IMAGEADJ_%1"[CR]	
%1	<p>"RST"----- Reset adjusted value for the Image</p> <p>"STR1"---- Store current adjusted value to Image 1</p> <p>"STR2"---- Store current adjusted value to Image 2</p> <p>"STR3"---- Store current adjusted value to Image 3</p> <p>"STR4"---- Store current adjusted value to Image 4</p> <p>"STR5"---- Store current adjusted value to Image 5</p> <p>"STR6"---- Store current adjusted value to Image 6</p> <p>"STR7"---- Store current adjusted value to Image 7</p> <p>"STR8"---- Store current adjusted value to Image 8</p> <p>"STR9"---- Store current adjusted value to Image 9</p> <p>"STR10"---- Store current adjusted value to Image 10</p>	
Details	<p>Reset or Store adjusted value for Image.</p> <p>(Available only in the normal Power ON status)</p> <p>"STR1"-"STR10" corresponds to "Image1"-"Image10" displayed in projector OSD menu on selecting "Store" for adjusted value of Image. The setting value set in "Image1" to "Image10" is stored and can be retrieved when turning on the projector again after the power is turned to ALL OFF status.</p>	
Response	Acceptable	"000" [CR]
	Unacceptable	"Error Code" [CR]

8.4.14 CF_APCTRL Command

Command	"CF_APCTRL_%1" [CR]	
%1	<p>"L1" ----- Set Auto Picture Control to Level 1.</p> <p>"L2" ----- Set Auto Picture Control to Level 2.</p> <p>"OFF" ----- Set Auto Picture Control OFF.</p> <p>" UP" ----- Switch setting forward direction (OFF→L1→L2→OFF)</p> <p>" DN" ----- Switch setting backward direction (OFF→L2→L1→OFF)</p>	
Details	Set Auto Picture Control (Available only in the normal Power ON status)	
Response	Acceptable	"000" [CR]

	Unacceptable	"Error Code" [CR]
--	--------------	-------------------

8.4.15 CF_COLMNSAV Command

Command	"CF_COLMNSAV_%1" [CR]	
%1	"000 – 009" ----- Specify the area to store	
Details	Store current setting status of Color Management to the area specified in %1. (Available only in the normal Power ON status)	
Response	Acceptable	"000" [CR]
	Unacceptable	"Error Code" [CR]

8.4.16 CF_COLMNL D Command

Command	"CF_COLMNL D_%1" [CR]	
%1	"000 – 009" ----- Specify the area to store	
Details	Retrieve Color Management setting status from the area specified in %1. (Available only in the normal Power ON status)	
Response	Acceptable	"000" [CR]
	Unacceptable	"Error Code" [CR]

8.5 PC Adjust Control Command

8.5.1 CF_FSYNC Command

Command	"CF_FSYNC_%1" [CR]	
%1	"0000-0031" ----- Directly specify setting value of Fine Sync "UP" ----- Increment setting value of Fine Sync by 1 "DN" ----- Decrement setting value of Fine Sync by 1	
Details	Set value of Fine Sync in PC signal (Available only in the normal Power ON status) The value set by this command will not be stored in the projector's memory. Therefore, when the power is turned to ALL OFF status, the value returns to the original setting. (It is stored in Standby mode.)	
Response	Acceptable	"000" [CR]
	Unacceptable	"101" [CR] --- When input is Video signal

8.5.2 CF_TDOTS Command

Command	"CF_TDOTS_%1" [CR]	
%1	"mmmm - nnnn" ----- Directly specify setting value of Total Dots "mmmm" indicates minimum value, which is current (Display area H + Position H) value "nnnn" indicates maximum value, which is <i>less than 140 MHz in Dot Clocks</i> "UP" ----- Increment setting value of Total Dots by 1 "DN" ----- Decrement setting value of Total Dots by 1	
Details	Set value of Total Dots in PC signal (Available only in the normal Power ON status) The value set by this command will not be stored in the projector's memory. Therefore, when the power is turned to ALL OFF status, the value returns to the original setting. (It is stored in Standby mode.)	
Response	Acceptable	"000" [CR]
	Unacceptable	"101" [CR] --- When input is Video signal

8.5.3 CF_CLPPHASE Command

Command	"CF_CLPPHASE_%1" [CR]	
%1	"0001-0255" ----- Directly specify setting value of Clamp Phase "UP" ----- Increment setting value of Clamp Phase by 1 "DN" ----- Decrement setting value of Clamp Phase by 1	
Details	Set value of Clamp Phase (Available only in the normal Power ON status) The value set by this command will not be stored in the projector. Therefore, when the power is turned to ALL OFF, the value returns to the original setting. (It is stored in Standby mode.)	
Response	Acceptable	"000" [CR]
	Unacceptable	"Error Code" [CR]

8.5.4 CF_H-POS Command

Command	"CF_H-POS_%1" [CR]	
%1	"0000-nnnn" ----- Directly specify setting value of Horizontal Position "nnnn" indicates maximum value, which is current value of (Total dots - Display area H) "UP" ----- Increment setting value of Horizontal Position by 1 "DN" ----- Decrement setting value of Horizontal Position by 1	
Details	Set value of Horizontal Position in PC signal (Available only in the normal Power ON status) The value set by this command will not be stored in the projector's memory. Therefore, when the power is turned to ALL OFF status, the value returns to the	

	original setting. (It is stored in Standby mode.)	
Response	Acceptable	"000" [CR]
	Unacceptable	"101" [CR] --- When input is Video signal

8.5.5 CF_V-POS Command

Command	"CF_V-POS_%1" [CR]	
%1	<p>"0000-nnnn" ----- Directly specify setting value of Vertical Position "nnnn" indicates maximum value, which is current (Total Line – Display Area V) value "UP" ----- Increment setting value of Vertical Position by 1 "DN" ----- Decrement setting value of Vertical Position by 1</p>	
Details	<p>Set Vertical Position value (Available only in the normal Power ON status) The value set by this command will not be stored in the projector's memory. Therefore, when the power is turned to ALL OFF status, the value returns to the original setting. (It is stored in Standby mode.)</p>	
Response	Acceptable	"000" [CR]
	Unacceptable	"101" [CR] ---- When input is Video signal

8.5.6 CF_DDOTS Command

Command	"CF_DDOTS_%1" [CR]	
%1	<p>"0100-nnnn" ----- Directly specify setting value of Display Dots "nnnn" indicates maximum value, which is current value of (Total Dots - Position H). In this projector, the value should be "even number" and if "odd number" is specified, it adds 1 to make the value even number. "UP" ----- Increment setting value of Display Dots by 2 "DN" ----- Decrement setting value of Display Dots by 2</p>	
Details	<p>Set setting value of Display Dots in PC signal (Available only in the normal Power ON status) The value set by this command will not be stored in the projector's memory. Therefore, when the power is turned to ALL OFF status, the value returns to the original setting. (It is stored in Standby mode.)</p>	
Response	Acceptable	"000" [CR]
	Unacceptable	"101" [CR] --- When input is Video signal

8.5.7 CF_DLINE Command

Command	"CF_DLINE_%1" [CR]	
%1	<p>"0100-nnnn" ----- Directly specify setting value of Display Line "nnnn" indicates maximum value, which is current value of (Total Line - Position V). "UP" ----- Increment setting value of Display Line by 1 "DN" ----- Decrement setting value of Display line by 1</p>	
Details	<p>Set setting value of Display Line in PC signal (Available only in the normal Power ON status) The value set by this command will not be stored in the projector's memory. Therefore, when the power is turned to ALL OFF status, the value returns to the original setting. (It is stored in Standby mode.)</p>	
Response	Acceptable	"000" [CR]
	Unacceptable	"101" [CR] --- When input is Video signal

8.5.8 CF_SETPCADJ Command

Command	"CF_SETPCADJ_%1" [CR]	
%1	None "EXT11-60"	

PLC-XP100L Expand Serial Command Functional Specifications

Details	When "EXT11-60" is specified in %1, "Ex Mode" (not like XGA1) is displayed in "SYSTEM" menu.	
Response	Acceptable	"000" [CR]
	Unacceptable	"101" [CR] --- When input is Video signal

8.5.9 CF_ORGMODE Command

Command	"CF_ORGMODE_%1" [CR]	
%1	When input signal is PC Analog; "VGA1" ----- Specify VGA1 "VGA2" ----- Specify VGA2 : : "XGA1" ----- Specify XGA1 : : "WXGA3" ----- Specify WXGA3 "1080i60" ----- Specify 1080i60 "1080i50" ----- Specify 1080i50 "1035i" ----- Specify 1035i "720p60" ----- Specify 720p60 "720p50" ----- Specify 720p50 "575p" ----- Specify 575p "480p" ----- Specify 480p "575i" ----- Specify 575i "480i" ----- Specify 480i "1080psf/24" ----- Specify 1080psf/24 "1080psf/25" ----- Specify 1080psf/25 "1080psf/30" ----- Specify 1080psf/30 * When input signal is not PC Analog, error code "101" is returned.	
Details	After "EXT n" is set by PC control command such as CF_FSYNC/CF_TDOTS and CF_SETPCADJ command, specify the signal originated with by issuing this command. This command is used to specify projector internal settings such as whether or not to get PC signal through IP (Available only in the normal Power ON status) Note; To differentiate between 60Hz and 50Hz in 1080i and 720p, "60" or "50" is necessary to add to the parameter in this command.	
Response	Acceptable	"000" [CR]
	Unacceptable	"101" [CR] --- When input is Video signal

8.5.10 CF_PCSTORE Command

Command	"CF_PCSTORE_%1" [CR]	
%1	"1" ----- Store current value of PC Adjust to Mode1 "2" ----- Store current value of PC Adjust to Mode2 "3" ----- Store current value of PC Adjust to Mode3 "4" ----- Store current value of PC Adjust to Mode4 "5" ----- Store current value of PC Adjust to Mode5 "6" ----- Store current value of PC Adjust to Mode6 "7" ----- Store current value of PC Adjust to Mode7 "8" ----- Store current value of PC Adjust to Mode8 "9" ----- Store current value of PC Adjust to Mode9 "10" ----- Store current value of PC Adjust to Mode10	
Details	Store current value of PC Adjust (each parameter status such as Total dots) to Mode1-10. This command operates the same way as storing to Mode1-10 in PC Adjust Menu. (Available only in the normal Power ON status)	
Response	Acceptable	"000" [CR]
	Unacceptable	"101" [CR] --- When input is Video signal

8.5.11 CF_PCMODEFREE Command

Command	"CF_PCMODEFREE_%1" [CR]	
%1	"1" ----- Set Mode1 to Free status "2" ----- Set Mode2 to Free status "3" ----- Set Mode3 to Free status "4" ----- Set Mode4 to Free status "5" ----- Set Mode5 to Free status "6" ----- Set Mode6 to Free status "7" ----- Set Mode7 to Free status "8" ----- Set Mode8 to Free status "9" ----- Set Mode9 to Free status "10" ----- Set Mode10 to Free status	
Details	Delete the data registered in Custom Mode1–10 and returns it to Free status. This command operates the same way as storing to Mode1-10 in PC Adjust Menu. (Available only in the normal Power ON status)	
Response	Acceptable	"000" [CR]
	Unacceptable	"101" [CR] --- When input is Video signal

8.6 Input Control Command

8.6.1 CF_INPUT Command

Command	"CF_INPUT_%1" [CR]	
%1	"1"----- Select Input 1 (not switching Source) "2"----- Select Input 2 (not switching Source) "3"----- Select Input 3 (not switching Source) "4"----- Select Input 4 (Network viewer) "UP"----- Increment Input No. by 1 <with PJ-Net attached>Input1→Input2→Input3→Input4→Input1→ - - - <with PJ-Net unattached>Input1→Input2→Input3→Input1→ - - - "DN"----- Decrement Input No. by 1 <with PJ-Net attached>Input1→Input2→Input3→Input4→Input1→ - - - <with PJ-Net unattached>Input1→Input2→Input3→Input1→ - - -	
Details	Select Input (Available only in the normal Power ON status) This command switches only Input No, not Source. For instance, when Input 1 has been selected, receiving the command to select Input 1 does not invoke source-switching operation. That means it operates differently from "INPUT" button of Projector or Remote Control. *When selecting Input4 on a projector with PJ-Net unattached, it comes to "103". *When selecting Input1 on a projector with PJ-Net attached and power OFF, It comes to "101".	
Response	Acceptable	"000" [CR]
	Unacceptable	"%%%" [CR]

8.6.2 CF_SOURCE Command

Command	"CF_SOURCE_%1" [CR]	
%1	Input 1	"DIGITAL" ----- Select RGB (PC Digital) Input "ANALOG" ----- Select RGB (PC Analog) Input "SCART" ----- Select RGB (Scart) input "HDCP" ----- Select RGB (AV HDCP) input "UP" ----- Select in PC Analog → Scart → PC Digital → AV HDCP → PC Analog order "DN" ----- Select in PC Analog → AV HDCP → PC Digital → Scart → PC Analog order
	Input 2	"VIDEO" ----- Select Video input "YPBPR" ----- Select Y,Pb/Cb,Pr/Cr input "ANALOG" ----- Select RGB input "UP" ----- Select in VIDEO → YPBPR → RGB → VIDEO order "DN" ----- Select in VIDEO → RGB → YPBPR → VIDEO order
	Input 3	"VIDEO" -----Select Video input "S-VIDEO" ----- Select S-Video input "YPBPR" ----- Select Y,Pb/Cb,Pr/Cr input "UP" ----- Select in VIDEO → YPBPR → S-VIDEO → VIDEO order "DN" ----- Select in VIDEO → S-VIDEO → YPBPR → VIDEO order
	Input 4	"NETWORK", "UP", "DN" *Input can not be selected, but above parameter is processed as Acceptable.
Details	Select Source of currently selected Input (Available only in the normal Power ON status) When selected input does not include specified %1, error code "101" is returned and it is not executed. When Input No is 4 and PJ-Net power is OFF, error code "101" is returned.	
Response	Acceptable	"000" [CR]
	Unacceptable	"%%%" [CR]

8.6.3 CF_INPUT 1 Command

Command	"CF_INPUT1_%1" [CR]	
%1	"DIGITAL" ----- Select PC Digital Input "ANALOG" ----- Select PC Analog Input "SCART" ----- Select SCART Input "HDCP" ----- Select DVI HDCP Input	
Details	Select Input 1 as well as Source specified in %1 (Available only in the normal Power ON status)	
Response	Acceptable	"000" [CR]
	Unacceptable	"%%%" [CR]

8.6.4 CF_INPUT 2 Command

Command	"CF_INPUT2_%1" [CR]	
%1	"VIDEO" ----- Select Composite Video Input "YPBPR" ----- Select Y/Pb/Pr Input "ANALOG" ----- Select RGB Input	
Details	Select Input 2 as well as Source specified in %1. (Available only in the normal Power ON status)	
Response	Acceptable	"000" [CR]
	Unacceptable	"%%%" [CR]

8.6.5 CF_INPUT 3 Command

Command	"CF_INPUT3_%1" [CR]	
%1	"VIDEO" ----- Select Composite Video Input "S-VIDEO" ----- Select S-Video Input "YPBPR" ----- Select Y/Pb/Pr Input	
Details	Select Input 3 as well as Source specified in %1. (Available only in the normal Power ON status)	
Response	Acceptable	"000" [CR]
	Unacceptable	"%%%" [CR]

8.6.6 CF_INPUT 4 Command

Command	"CF_INPUT4_%1" [CR]	
%1	"NETWORK" ----- Select input from PJ-Net	
Details	Select Input 4 as well as Source specified in %1. (Available only in the normal Power ON status) *With PJ-Net unattached, this command is invalid and error code "103" is returned. *With PJ-Net attached and the power OFF, error code "101" is returned.	
Response	Acceptable	"000" [CR]
	Unacceptable	"%%%" [CR]

8.6.7 CF_SYSTEM Command

Command	"CF_SYSTEM_%1" [CR]	
%1	Input is PC Analog	"VGA1" ----- Select VGA1 "VGA2" ----- Select VGA2 : : "XGA1" ----- Select XGA1 :

PLC-XP100L Expand Serial Command Functional Specifications

		<p> : "WXGA3" ----- Select WXGA3 "1080I" ----- Select 1080i "1035I" ----- Select 1035i "720p" ----- Select 720p "575p" ----- Select 575p "480p" ----- Select 480p "575I" ----- Select 575i "480I" ----- Select 480i "1080psf/24" ----- Select 1080psf/24 "1080psf/25" ----- Select 1080psf/25 "1080psf/30" ----- Select 1080psf/30 "MODE 1 - 10" ----- Select MODE1 – MODE10 "EXT11 - 60" ----- Select Ex Mode11-60 * Mode1-10 is not returned. </p>
	Input is PC Digital/AV HDCP	<p> "D-XGA1" ----- Select D-XGA1 : : "D-WXGA3"----- Select D-WXGA3 "D-1080I" ----- Select D-1080i "D-1035I" ----- Select D-1035i "D-720p" ----- Select D-720p "D-575p" ----- Select D-575p "D-480p" ----- Select D-480p "D-1080psf/24" ----- Select D-1080psf/24 "D-1080psf/25" ----- Select D-1080psf/25 "D-1080psf/30" ----- Select D-1080psf/30 </p>
	Input is Y,Pb/Cb,Pr/Cr	<p> "AUTO" ----- Select System "Auto" "1080I" ----- Select 1080i "1035I" ----- Select 1035i "720P" ----- Select 720p "575P" ----- Select 575p "480P" ----- Select 480p "575I" ----- Select 575i "480I" ----- Select 480i </p>
	Input is Video / S-Video	<p> "AUTO" ----- Select System "Auto" "NTSC" ----- Select NTSC "NTSC443" ----- Select NTSC4.43 "PAL" ----- Select PAL "SECAM" ----- Select SECAM "PAL-M" ----- Select PAL-M "PAL-N" ----- Select PAL-N </p>
Details	<p> Select System of currently selected Input (Available only in the normal Power ON status) When selected input does not include specified %1, error code "101" [CR] is returned and it is not executed. When Input No is 4, error code "101" [CR] is returned and it is not executed. </p>	
Response	Acceptable	"000" [CR]
	Unacceptable	"Error Code" [CR]

8.7 Screen Control Command

8.7.1 CF_SCREEN Command

Command	"CF_SCREEN_%1" [CR]	
%1	Input is Computer	"NORMAL" ----- Select Normal mode "WIDE" ----- Select Wide mode "TRUE" ----- Select True mode "FULL" ----- Select Full screen mode "CUSTOM" ----- Select Custom mode "DZOOM_UP" ----- Scale up with Digital zoom "DZOOM_DN" ----- Scale down with Digital zoom "UP" ----- Select screen size with forward swiching in possible range "DN" ----- Select screen size with backward swiching in possible range
	Input is Video	"NORMAL" ----- Select Normal mode "WIDE" ----- Select Wide mode "FULL" ----- Select Full mode "UP" ----- Select screen size with forward swiching in possible range "DN" ----- Select screen size with backward swiching in possible range
	Common in AV/PC	"RST" ----- Reset Screen adjustment
Details	Select screen size (Available only in the normal Power ON status) When selected input does not include specified %1, error code "101" [CR] is returned and it is not executed. Receiving "DZOOM_UP" or "DZOOM_DN" command immediately executes the function.	
Response	Acceptable	"000" [CR]
	Unacceptable	"Error Code" [CR]

8.7.2 CF_VSCALE Command

Command	"CF_VSCALE_%1" [CR]	
%1	"035" ----- +35 "031" ----- +31 : "002" ----- +2 "001" ----- +1 "000" ----- ±0 " 01" ----- 1 " 02" ----- 2 : " 31" ----- 31 " 32" ----- 32 "UP" ----- Increment setting value of Vscale by 1 "DN" ----- Decrement setting value of Vscale by 1	
	Details	Set Vscale (Available only in the normal Power ON status)
Response	Acceptable	"000" [CR]
	Unacceptable	"Error Code" [CR]

8.7.3 CF_VPOS Command

Command	"CF_VPOS_%1" [CR]	
%1	"015" ----- +15 "014" ----- +14 : "002" ----- +2 "001" ----- +1	

	"000" ----- ±0 " 01" ----- 1 " 02" ----- 2 : " 14" ----- 14 " 15" ----- 15 "UP" ----- Increment setting value of Vposition by 1 "DN" ----- Decrement setting value of Vposition by 1
Details	Set V Position (Available only in the normal Power ON status)
Response	Acceptable "000" [CR]
	Unacceptable "Error Code" [CR]

8.7.4 CF_HSCALE Command

Command	"CF_HSCALE_%1" [CR]	
%1	"035" ----- +35 "031" ----- +31 : "002" ----- +2 "001" ----- +1 "000" ----- ±0 " 01" ----- 1 " 02" ----- 2 : " 31" ----- 31 " 32" ----- 32 "UP" ----- Increment setting value of Hscale by 1 "DN" ----- Decrement setting value of Hscale by 1	
Details	Set Hscale (Available only in the normal Power ON status)	
Response	Acceptable	"000" [CR]
	Unacceptable	"Error Code" [CR]

8.7.5 CF_HPOS Command

Command	"CF_HPOS_%1" [CR]	
%1	"015" ----- +15 "014" ----- +14 : "002" ----- +2 "001" ----- +1 "000" ----- ±0 " 01" ----- 1 " 02" ----- 2 : " 14" ----- 14 " 15" ----- 15 "UP" ----- Increment setting value of Hposition by 1 "DN" ----- Decrement setting value of Hposition by 1	
Details	Set H Position (Available only in the normal Power ON status)	
Response	Acceptable	"000" [CR]
	Unacceptable	"Error Code" [CR]

8.7.6 CF_DZCENT Command

Command	"CF_DZCENT_%1" [CR]
%1	"CENT" ----- Cancel Digital Zoom (CENT: "CENTER")

Details	Cancel Digital Zoom (Available only in the normal Power ON status and Input for Computer is selected)	
Response	Acceptable	"000" [CR]
	Unacceptable	"101" [CR] ----- When input is Video

8.7.7 CF_KEYSTONE Command

Command	"CF_KEYSTONE_%1" [CR]	
%1	"UP" ----- Correct Keystone distortion to reduce upper part of image "FUP" ----- Correct Keystone distortion to reduce upper part largely "DN" ----- Correct Keystone distortion to reduce lower part of image "FDN" ----- Correct Keystone distortion to reduce lower part largely "LEFT" ----- Correct Keystone distortion to reduce left part of image "FLFT" ----- Correct Keystone distortion to reduce left part largely "RIGHT" ----- Correct Keystone distortion to reduce right part of image "FRGT" ----- Correct Keystone distortion to reduce right part largely "RST" ----- Set Keystone OFF	
Details	Change level of Keystone distortion correction (Available only in the normal Power ON status). When reached the limit of the correction level, projector accepts the command but does not execute it. Receiving this command immediately invokes the operation. When trying to set the value beyond available range, error code "201" is returned and the operation is not executed. Example 1: When the correction level of the right part has reached its upper limit and then the command "RIGHT" is received Example 2: When the upper part correction allows only another step, and then the command "FUP" is received.	
Response	Acceptable	"000" [CR]
	Unacceptable	"Error Code" [CR]

8.7.8 CF_KYSTNMODE Command

Command	"CF_KYSTNMODE_%1" [CR]	
%1	"STR" ----- Set Keystone store mode to Store "RST" ----- Set Keystone store mode to Reset	
Details	Set Keystone store mode (Available only in the normal Power ON status)	
Response	Acceptable	"000" [CR]
	Unacceptable	"Error Code" [CR]

8.8 Lamp Command

8.8.1 CF_LAMPH Command

Command	"CF_LAMPH_%1" [CR]	
%1	"RST"	
Details	Reset lamp running time (Available only in the normal Power ON status)	
Response	Acceptable	"000" [CR]
	Unacceptable	"Error Code" [CR]

8.8.2 CF_LAMPMODE Command

Command	"CF_LAMPMODE_%1" [CR]	
%1	"NORMAL" ----- Set Lamp status to Normal mode "ECO1" ----- Set Lamp status to Eco1 mode "ECO2" ----- Set Lamp status to Eco2 mode "AUTO" ----- Set Lamp status to Auto mode	
Details	Select Lamp mode (Available only in the normal Power ON status) The value set by this command is stored in EEPROM and the setting remains effective after the power is turned to ALL OFF status.	
Response	Acceptable	"000" [CR]
	Unacceptable	"Error Code" [CR]

8.9 Setting Command

8.9.1 CF_BACKGND Command

Command	"CF_BACKGND_%1" [CR]	
%1	"BLUE" ----- Select Blue Back "USER" ----- Select User "BLACK" ----- Select Black Back "UP" ----- Switch forward (Blue Back→User→Black Back→Blue Back) "DN" ----- Switch backward (Blue Back→Black Back→User→Blue Back)	
Details	Set Screen status for no signal.(Available only in the normal Power ON status) The status set by this command is stored in EEPROM and the setting remains even after the power is turned to ALL OFF status. *When %1="USER" is received, error code "101" is returned, in the case of Capture non-practice.	
Response	Acceptable	"000" [CR]
	Unacceptable	"Error Code" [CR]

8.9.2 CF_DISP Command

Command	"CF_DISP_%1" [CR]	
%1	"ON" ----- Select Display "CNTDWN OFF" ----- Select Count down Off "OFF" ----- Cancel Display "UP" ----- Switch forward (On → Count down Off → Off → On → ---) "DN" ----- Switch backward (On → Off → Count down Off → On → ---)	
Details	Set Display mode.(Available only in the normal Power ON status) The value set by this command is stored in EEPROM and setting remains effective even after the power is turned to ALL OFF status.	
Response	Acceptable	"000" [CR]
	Unacceptable	"Error Code" [CR]

8.9.3 CF_LOGO Command

Command	"CF_LOGO_%1_%2" [CR]	
%1	"0000 – 9999" ----- Directly set Logo PIN code	
%2	"OFF" -----Cancel Logo display "DFLT" ----- Select Logo of Factory Default "USER" ----- Select User "UP" ----- Select functions to choose forward (OFF → DFLT → USER → OFF → --) "DN" ----- Select functions to choose backward (OFF → USER → DFLT → OFF → --)	
Details	Set Logo mode.(Available only in the normal Power ON status) The status set by this command is stored in EEPROM and setting remains effective even after the power is turned to ALL OFF status. Set Logo PIN code in %1. When Logo Lock is enabled: PIN code is matched ----- Command is valid (Acceptable) PIN code is mismatched----- Command is invalid (Error code "102") PIN code is beyond %1 available range ----- Command is invalid (Error code "?") When Logo Lock is disabled: PIN code is within %1 available range ----- Command is valid (Acceptable) PIN code is out of %1 available range ----- Command is invalid (Error code "?") Note: When Logo Lock is enabled, matching Logo PIN code switches Logo but Logo Lock is not cancelled (Lock status is kept). *When %2="USER" is received, error code "101" is returned, in the case of Capture non-practice.	
Response	Acceptable	"000" [CR]

	Unacceptable	"Error Code" [CR]
--	--------------	-------------------

8.9.4 CF_CEIL Command

Command	"CF_CEIL_%1" [CR]	
%1	"ON" ----- Set Ceiling to ON. "OFF" ----- Set Ceiling to OFF.	
Details	Set/Cancel Ceiling mode.(Available only in the normal Power ON status) The status set by this command is stored in EEPROM and setting remains effective even after the power is turned to ALL OFF status.	
Response	Acceptable	"000" [CR]
	Unacceptable	"Error Code" [CR]

8.9.5 CF_REAR Command

Command	"CF_REAR_%1" [CR]	
%1	"ON" ----- Set Rear to ON. "OFF" ----- Set Rear to OFF.	
Details	Set/Cancel Rear mode (Available only in the normal Power ON status) When Rear is ON, projected image is left/right reversed. The status set by this command is stored in EEPROM and setting remains effective even after the power is turned to ALL OFF status.	
Response	Acceptable	"000" [CR]
	Unacceptable	"Error Code" [CR]

8.9.6 CF_RCODE Command

Command	"CF_RCODE_%1" [CR]	
%1	"001" ----- Select Code 1 "002" ----- Select Code 2 "003" ----- Select Code 3 "004" ----- Select Code 4 "005" ----- Select Code 5 "006" ----- Select Code 6 "007" ----- Select Code 7 "008" ----- Select Code 8 "UP" ----- Switch forward (Code1→Code2→Code3 - - - →Code8→Code1) "DN" ----- Switch backward (Code8→Code7→Code6 - - - →Code1→Code8)	
Details	Select Code of Remote Control (Available only in the normal Power ON status) The status set by this command is stored in EEPROM and setting remains effective even after the power is turned to ALL OFF status.	
Response	Acceptable	"000" [CR]
	Unacceptable	"Error Code" [CR]

8.9.7 CF_RSENS Command

Command	"CF_RSENS_%1" [CR]	
%1	"BOTH" ----- Select both front and back receiver of projector "FRONT" ----- Select only front receiver of projector "BACK" ----- Select only back receiver of projector "UP" ----- Switch forward (BOTH → FRONT → BACK → BOTH) "DN" ----- Switch backward (BACK → FRONT → BOTH → BACK)	
Details	Select location of infrared remote receiver of remote control (Available only in the normal Power ON status) The status set by this command is stored in EEPROM and setting remains effective even after the power is turned to ALL OFF status.	

Response	Acceptable	"000" [CR]
	Unacceptable	"Error Code" [CR]

8.9.8 CF_LANG Command

Command	"CF_LANG_%1" [CR]	
%1	"ENG" ----- Select ENGLISH "DEU" ----- Select German "FRA" ----- Select French "ITA" ----- Select Italian "ESP" ----- Select Spanish "POR" ----- Select Portuguese "NED" ----- Select Dutch "SVE" ----- Select Swedish "JPN" ----- Select Japanese "CHI" ----- Select Chinese "KOR" ----- Select Korean "RUS" ----- Select Russian	
Details	Set language for OSD (Available only in the normal Power ON status) The language set by this command is stored in EEPROM and setting remains effective even after the power is turned to ALL OFF status.	
Response	Acceptable	"000" [CR]
	Unacceptable	"Error Code" [CR]

8.9.9 CF_ON-STA Command

Command	"CF_ON-STA_%1" [CR]	
%1	"ON" ----- Set Power On Start to ON. "OFF" ----- Set Power On Start to OFF. "UP" ----- Toggle between ON and OFF.(On→Off→On → - - -) "DN" ----- Toggle between ON and OFF.(On→Off→On → - - -) *)"UP" and "DN" are exactly same operation.	
Details	Set/Cancel Power ON Start (Available only in the normal Power ON status) The status set by this command is stored in EEPROM and setting value remains effective even after the power is turned to ALL OFF status.	
Response	Acceptable	"000" [CR]
	Unacceptable	"Error Code" [CR]

8.9.10 CF_P-MANE Command

Command	"CF_P-MANE_%1" [CR]	
%1	"OFF" ----- Set Power Management to Off "READY" ----- Set Power Management to Ready "SHUTDOWN" ----- Set Power Management to Shut Down mode "UP" ----- Switch forward (Off→Ready→Shut down→Off) "DN" ----- Switch backward (Off→Shut down→Ready→Off)	
Details	Set/Cancel Power Management (Available only in the normal Power ON status) The status set by this command is stored in EEPROM and setting remains effective even after the power is turned to ALL OFF status.	
Response	Acceptable	"000" [CR]
	Unacceptable	"Error Code" [CR]

8.9.11 CF_P-MANETIME Command

Command	"CF_P-MANETIME_%1" [CR]	
%1	"01" - "30" ----- Directly specify setting time by the minute "UP" ----- Increment value by 1 (Switched in 01→02→ --- → 30 → 01 order) "DN" ----- Decrement value by 1 (Switched in 30→29→ --- → 01 → 30 order)	
Details	Set time of Power Management time (Available only in the normal Power ON status) The status set by this command is stored in EEPROM and setting remains effective even after the power is turned to ALL OFF status.	
Response	Acceptable	"000" [CR]
	Unacceptable	"Error Code" [CR]

8.9.12 CF_FANSPEED Command

Command	"CF_FANSPEED_%1" [CR]	
%1	"MAX" ----- Select maximum fan speed "NOR" ----- Select normal fan speed	
Details	Switch Fan Control Speed mode.(Available only in the normal Power ON status) The status set by this command is stored in EEPROM and setting remains effective even after the power is turned to ALL OFF status.	
Response	Acceptable	"000" [CR]
	Unacceptable	"Error Code" [CR]

8.9.13 CF_KEYDIS Command

Command	"CF_KEYDIS_%1" [CR]	
%1	"NONE" ----- RC and KEY are both enabled. "RC" ----- RC is disabled. "KEY" ----- KEY is disabled.	
Details	Disable RC and/or KEY functions (Available only in the normal Power ON status)	
Response	Acceptable	"000" [CR]
	Unacceptable	"Error Code" [CR]

8.9.14 CF_FDEFAULT Command

Command	"CF_FDEFAULT_%1" [CR]	
%1	"RST"	
Details	Reset to Factory Default setting (Available only in the normal Power ON status)	
Response	Acceptable	"000" [CR]
	Unacceptable	"Error Code" [CR]

8.9.15 CF_PJPINCODE Command

Command	"CF_PJPINCODE_%1" [CR]	
%1	"0000 – 9999" ----- Directly specify PJ PIN code	
Details	<p>Enter PIN code to cancel PIN code lock (Available only in the normal Power ON status) PIN code can not be changed. (Only PIN code lock is canceled.) *When PIN code Lock is enabled: PIN code is matched ----- Command is valid (Acceptable) PIN code is mismatched ----- Command is invalid (Error code "102") PIN code is beyond %1 available range ----- Command is invalid (Error code "?") When PIN code lock is canceled: PIN code is within %1 range ----- Command is valid (Acceptable) PIN code is out of %1 range ----- Command is invalid (Error code is 102)</p> <p>This command is only valid when "PJ PIN code" dialog is displayed to enter PIN code after Power is ON and Countdown is completed. When PIN code lock is set to "On1", it needs to send this command every time the projector is turned on.</p>	
Response	Acceptable	"000" [CR]
	Unacceptable	"Error Code" [CR]

8.9.16 CF_TESTPAT Command

Command	"CF_TESTPAT_%1" [CR]	
%1	<p>"COLOR" ----- Display Color bar "GRAD1" ----- Display 16step(white→black) "GRAD2" ----- Display 16step(white←black) "GRAD3" ----- Display 16step(white↓black) "GRAD4" ----- Display 16step(white↑black) "WHITE" ----- Display all white "BALCK" ----- Display all black "CROSS" ----- Display Cross "OFF" ----- Do not show test pattern display "UP" ----- Switch forward "DN" ----- Switch backward</p>	
Details	Execute test pattern display. (Available only in the normal Power ON status)	
Response	Acceptable	"000" [CR]
	Unacceptable	"Error Code" [CR]

8.9.17 CF_FILH Command

Command	"CF_FILH_%1" [CR]	
%1	"RST" ----- Reset Filter used time	
Details	Reset used time for filter of projector	
Response	Acceptable	"000" [CR]
	Unacceptable	"Error Code" [CR]

8.9.18 CF_FILTERTIMER Command

Command	"CF_FILTERTIMER_%1" [CR]	
%1	<p>"0400" ----- Set 400 hours "0700" ----- Set 700 hours "1000" ----- Set 1000 hours "OFF" ----- Set Off(Do not warning display)</p>	

Details	Set time to display Filter cleaning / replacement warning on screen	
Response	Acceptable	"000" [CR]
	Unacceptable	"Error Code" [CR]

8.9.19 CF_FILCTL Command

Command	"CF_FILCTL_%1" [CR]	
%1	"ROLL" ----- Execute operation of scroll of filter	
Details	Execute operation of scroll of filter	
Response	Acceptable	"000" [CR]
	Unacceptable	"Error Code" [CR]

8.9.20 CF_FILSCL Command

Command	"CF_FILSCL_%1" [CR]	
%1	"RST" ----- Reset Filter scroll counter	
Details	Reset Filter scroll counter	
Response	Acceptable	"000" [CR]
	Unacceptable	"Error Code" [CR]

8.9.21 CF_POINTER Command

Command	"CF_POINTER_%1" [CR]	
%1	"ARROW" ----- Select Arrow Pointer "FINGER" ----- Select Finger Pointer "LASER" ----- Select Laser mark Pointer	
Details	Select indication of Pointer.	
Response	Acceptable	"000" [CR]
	Unacceptable	"Error Code" [CR]

8.10 Other Commands

8.10.1 CF_KEYEMU Command

Command	"CF_KEYEMU_%1" [CR]	
%1	"RIGHT" ----- Move Pointer rightward in On-Screen Display Menu "LEFT" ----- Move Pointer leftward in On-Screen Display Menu "UP" ----- Move Pointer to upward On-Screen Display Menu "DN" ----- Move Pointer to downward in On-Screen Display Menu "SELECT" ----- The same operation as "SELECT" button of RC "AUTOPC" ----- Execute Auto PC Adj. operation The same operation as "AUTO PC" button of RC When this is sent during Auto PC Adj. operation, the operation is stopped. This is same way as pressing "AUTO PC" button of RC.	
Details	The same operation as RC/Control Key.	
Response	Acceptable	"000" [CR]
	Unacceptable	"Error Code" [CR]

8.10.2 CF_MENU Command

Command	"CF_MENU_%1" [CR]	
%1	"ON" ----- Display On-Screen Display Menu	

	"OFF" ----- Hide On-Screen Display Menu	
Details	Set On-Screen Display mode. (Available only in the normal Power ON status)	
Response	Acceptable	"000" [CR]
	Unacceptable	"Error Code" [CR]

8.10.3 CF_POWER Command

Command	"CF_POWER_%1" [CR]	
%1	"ON" ----- Power ON "OFF" ----- Power OFF * Issuing another command during countdown process forced countdown operation to be terminated. * Error Code is returned in some projector statuses, which indicates the command is impossible to be executed. (See [8.3] for details) * Returning the response "000" [CR] (acceptable) does not always mean that the status has already changed to Power ON. Example: When the temperature approaches abnormal status after returning "000" [CR] to the command CF_POWER ON. Therefore, to get the projector status requires using Status Read command.	
Details	Set Power to ON/OFF	
Response	Acceptable	"000" [CR]
	Unacceptable	"Error Code" [CR]

8.10.4 CF_FREEZE Command

Command	"CF_FREEZE_%1" [CR]	
%1	"ON" ----- Set Freeze to ON. "OFF" ----- Set Freeze to OFF. "UP" ----- Switch forward (On→Off→On→---) "DN" ----- Switch backward (On→Off→On→---) * The same operation for "UP" and "DN" as this model has only "ON" / "OFF".	
Details	Set / Cancel Freeze function. (Available only in the normal Power ON status) Receiving FREEZE_ON command when the projector is Freeze enabled, Freeze status is kept.	
Response	Acceptable	"000" [CR]
	Unacceptable	"Error Code" [CR]

9 . Status Read Command

9.1 Format

- 1) PC issues commands in format as below:
 "CR_ **COMMAND**" [CR]
 Command: String
- 2) When projector receives the appropriate command, it returns the required data as a string.
 "000_" %1 [CR]
 %1: Required Data (String)
- 3) When the received data cannot be decoded, the projector returns "?" [CR]

9.2 Transfer Example

Get total dots of projector by Expand Serial Commands

PC → PJ: "CR_TDOTS" [CR]

PC ← PJ: "000_1344" [CR]

9.3 Operation Condition

Basically it should be always operated.

9.4 Image Status Read Command

9.4.1 CR_BRIGHT Command

Command	"CR_BRIGHT" [CR]	
Details	Get user controlled value of Brightness	
Response	Acceptable	"000_%1" [CR]
	%1	"000 – 063"
	Unacceptable	"?" [CR]

9.4.2 CR_CONT Command

Command	"CR_CONT" [CR]	
Details	Get user controlled value of Contrast	
Response	Acceptable	"000_%1" [CR]
	%1	"000 – 063"
	Unacceptable	"?" [CR]

9.4.3 CR_COLOR Command

Command	"CR_COLOR" [CR]	
Details	Get user controlled value of Color	
Response	Acceptable	"000_%1" [CR]
	%1	"000 – 063"
	Unacceptable	"?" [CR]

9.4.4 CR_TINT Command

Command	"CR_TINT" [CR]	
Details	Get user controlled value of Tint	
Response	Acceptable	"000_%1" [CR]
	%1	"000 – 063"
	Unacceptable	"Error Code" [CR] --- When command is not available in the given condition (such as being selected input). "?" [CR] --- When unknown command is received

9.4.5 CR_SHARP Command

Command	"CR_SHARP" [CR]	
Details	Get user controlled value of Sharpness	
Response	Acceptable	"000_%1" [CR]
	%1	"000 – 031"
	Unacceptable	"?" [CR]

9.4.6 CR_GAMMA Command

Command	"CR_GAMMA" [CR]	
Details	Get user controlled value of Gamma	
Response	Acceptable	"000_%1" [CR]
	%1	"000 – 015"
	Unacceptable	"?" [CR]

9.4.7 CR_WBAL-R Command

Command	"CR_WBAL-R" [CR]	
Details	Get user controlled Red value of White Balance	
Response	Acceptable	"000_%1" [CR]
	%1	"000 – 063"
	Unacceptable	"?" [CR]

9.4.8 CR_WBAL-G Command

Command	"CR_WBAL-G" [CR]	
Details	Get user controlled Green value of White Balance	
Response	Acceptable	"000_%1" [CR]
	%1	"000 – 063"
	Unacceptable	"?" [CR]

9.4.9 CR_WBAL-B Command

Command	"CR_WBAL-B" [CR]	
Details	Get user controlled Blue value of White Balance	
Response	Acceptable	"000_%1" [CR]
	%1	"000 – 063"
	Unacceptable	"?" [CR]

9.4.10 CR_COLTEMP Command

Command	"CR_COLTEMP" [CR]	
Details	Get Color Temperature setting status	
Response	Acceptable	"000_%1" [CR]
	%1	"000" ----- Xlow "001" ----- Low "002" ----- Mid "003" ----- High "BLANK" ---- OSD Menu is blank (Neither of Xlow / Low / Mid / High)
	Unacceptable	"?" [CR]

9.4.11 CR_OFFSET-R Command

Command	"CR_OFFSET-R" [CR]	
Details	Get user controlled Red value of Offset	
Response	Acceptable	"000_%1" [CR]
	%1	"000 – 063"
	Unacceptable	"?" [CR]

9.4.12 CR_OFFSET-G Command

Command	"CR_OFFSET-G" [CR]	
Details	Get user controlled Green value of Offset	
Response	Acceptable	"000_%1" [CR]
	%1	"000 – 063"
	Unacceptable	"?" [CR]

9.4.13 CR_OFFSET-B Command

Command	"CR_OFFSET-B" [CR]	
Details	Get user controlled Blue value of Offset	
Response	Acceptable	"000_%1" [CR]
	%1	"000 – 063"
	Unacceptable	"?" [CR]

9.4.14 CR_NZRED Command

Command	"CR_NZRED" [CR]	
Details	Get Noise Reduction setting status	
Response	Acceptable	"000_%1" [CR]
	%1	"OFF" ----- Cancel Noise Reduction "ON" ----- Set Noise Reduction
	Unacceptable	"?" [CR]

9.4.15 CR_PROGV Command

Command	"CR_PROGV" [CR]	
Details	Get Progressive scan setting status	

Response	Acceptable	"000_%1" [CR]
	%1	"ON" ----- Set Progressive scan On "FILM" ----- Select FILM mode "OFF" ----- Set Progressive scan Off
	Unacceptable	"?" [CR]

9.4.16 CR_IMAGE Command

Command	"CR_IMAGE" [CR]	
Details	Get image setting status	
Response	Acceptable	"000_%1" [CR]
	%1	"STAND" ----- Standard "REAL" ----- Real "CINEMA" ----- Cinema "CUSTOM1" ----- "Image1" "CUSTOM2" ----- "Image2" "CUSTOM3" ----- "Image3" "CUSTOM4" ----- "Image4" "CUSTOM5" ----- "Image5" "CUSTOM6" ----- "Image6" "CUSTOM7" ----- "Image7" "CUSTOM8" ----- "Image8" "CUSTOM9" ----- "Image9" "CUSTOM10" ----- "Image10"
	Unacceptable	"Error Code" [CR] ----- When command is not available in the given condition (such as being selected input "?" [CR] ----- When unknown command is received

9.4.17 CR_IMGGMD Command

Command	"CR_IMGGMD" [CR]	
Details	Get setting status of Standard/Real/Cinema in Image Gamma	
Response	Acceptable	"000_%1" [CR]
	%1	"STD" ----- Standard "REL" ----- Real "CNM" ----- Cinema
	Unacceptable	"?" [CR]

9.4.18 CR_APCTRL Command

Command	"CR_APCTRL" [CR]	
Details	Get setting status of Auto Picture Control	
Response	Acceptable	"000_%1" [CR]
	%1	"L1" ----- Operate Auto Picture Control with Level1 "L2" ----- Operate Auto Picture Control with Level2 "OFF" ----- Set Auto Picture Control OFF
	Unacceptable	"?" [CR]

9.5 PC Adjust Status Read Command

9.5.1 CR_FSYNC Command

Command	"CR_FSYNC" [CR]	
Details	Get value of Fine Sync	
Response	Acceptable	"000_%1" [CR]
	%1	"0000 – 0031"
	Unacceptable	"Error Code" [CR] --- When command is not available in the given condition (such as being selected input) "?" [CR] --- When unknown command is received

9.5.2 CR_TDOTS Command

Command	"CR_TDOTS" [CR]	
Details	Get value of Total Dots	
Response	Acceptable	"000_%1" [CR]
	%1	"mmmm" – "nnnn" (mmmm = Display area H + Position H) (nnnn = Maximum value less than 140 MHz of Dot Clock)
	Unacceptable	"Error Code" [CR] ----- When command is not available in the given condition (such as being selected input "?" [CR] ----- When unknown command is received

9.5.3 CR_CLPPHASE Command

Command	"CR_CLPPHASE" [CR]	
Details	Get value of Clamp Phase value	
Response	Acceptable	"000_%1" [CR]
	%1	"0001 – 0255"
	Unacceptable	"Error Code" [CR]

9.5.4 CR_H-POS Command

Command	"CR_H-POS" [CR]	
Details	Get value of Horizontal Position	
Response	Acceptable	"000_%1" [CR]
	%1	"0000 – nnnn" (nnnn = Total Dots – Display area H)
	Unacceptable	"Error Code" [CR] ----- When command is not available in the given condition (such as being selected input "?" [CR] ----- When unknown command is received

9.5.5 CR_V-POS Command

Command	"CR_V-POS" [CR]	
Details	Get value of Vertical Position	
Response	Acceptable	"000_%1" [CR]
	%1	"0000 – nnnn" (nnnn = Total Line – Display area V)
	Unacceptable	"Error Code" [CR] ----- When command is not available in the given condition (such as being selected input "?" [CR] ----- When unknown command is received

9.5.6 CR_DDOTS Command

Command	"CR_DDOTS" [CR]	
Details	Get value of Display Dots	
Response	Acceptable	"000_%1" [CR]
	%1	"0100 – nnnn" (nnnn = Total Dots – Position H)
	Unacceptable	"Error Code" [CR] ---- When command is not available in the given condition (such as being selected input "?" [CR] ----- When unknown command is received

9.5.7 CR_DLINE Command

Command	"CR_DLINE" [CR]	
Details	Get value of Display Line	
Response	Acceptable	"000_%1" [CR]
	%1	"0100 – nnnn" (nnnn = Total Line – Position V)
	Unacceptable	"Error Code" [CR] ---- When command is not available in the given condition (such as being selected input) "?" [CR] ----- When unknown command is received

9.5.8 CR_ORGMODE Command

Command	"CR_ORGMODE" [CR]	
Details	Get the original signal of current selected Mode that is set in PC Adj. When MODE1- 10 or EXT11-50 is not selected, get the current signal.	
Response	Acceptable	"000_%1" [CR]
	%1	When input signal is PC Analog; "VGA1" ----- Indicates signal is VGA1 "VGA2" ----- Indicates signal is VGA2 : : "XGA1" ----- Indicates signal is XGA1 : : "WXGA3" ----- Indicates signal is WXGA3 "1080i60" ----- Indicates signal is 1080i60 "1080i50" ----- Indicates signal is 1080i50 "1035i" ----- Indicates signal is 1035i "720p60" ----- Indicates signal is 720p60 "720p50" ----- Indicates signal is 720p50 "575p" ----- Indicates signal is 575p "480p" ----- Indicates signal is 480p "575i" ----- Indicates signal is 575i "480i" ----- Indicates signal is 480i "1080psf/24" ----- Indicates signal is 1080psf/24 "1080psf/25" ----- Indicates signal is 1080psf/25 "1080psf/30" ----- Indicates signal is 1080psf/30 Note: To differentiate between 60Hz and 50Hz in 1080i and 720p, "60" or "50" is necessary to add to the parameter in this command * When input signal is not PC Analog, error code "101" is returned.
	Unacceptable	"?" [CR]

9.5.9 CR_PCSTORE Command

Command	"CR_PCSTORE" [CR]	
Details	Get Free or Stored status of MODE1 - 5 in PC Adjust. Data consists of 10 bytes and each byte represents MODE1-10. (F:Free, S:Stored)	
Response	Acceptable	"000_%1" [CR]
	%1	"FFFFFFFF" ----- ALL Free "SFFFFFFFF" ----- Mode1 is Stored, others are Free : "FFFFFFFFS" ----- Mode10 is Stored, others are Free "SSSSSSSSS" ----- ALL Stored
	Unacceptable	"?" [CR]

9.5.10 CR_SETPCADJ Command

Command	"CR_SETPCADJ" [CR]	
Details	Get PC signal for current system	
Response	Acceptable	"000_%1" [CR]
	%1	When input signal is PC Analog; "VGA1" ----- Indicates VGA1 is selected "VGA2" ----- Indicates VGA2 is selected : : "XGA1" ----- Indicates XGA1 is selected : : "WXGA3" ----- Indicates WXGA3 is selected "1080i" ----- Indicates 1080i is selected "1035i" ----- Indicates 10350i is selected "720p" ----- Indicates 720p is selected "575p" ----- Indicates 575p is selected "480p" ----- Indicates 480p is selected "575i" ----- Indicates 575i is selected "480i" ----- Indicates 480i is selected "1080psf/24" ----- Indicates 1080psf/24 is selected "1080psf/25" ----- Indicates 1080psf/25 is selected "1080psf/30" ----- Indicates 1080psf/30 is selected : "MODE10" ----- Indicates Mode10 is selected "EXT11" ----- EXT11 is selected : "EXT60" ----- EXT60 is selected * Error Code "101" [CR] is returned for no signal. * When input signal is not PC Analog, error code "101" is returned.
	Unacceptable	"?" [CR]

9.6 Video Status Read Command

9.6.1 CR_SERSYS Command

Command	"CR_SERSYS" [CR]	
Details	Get selected current signal. Auto detected signal is returned in Auto mode Only available when Input is Y,Pb/Cb,Pr/Cr, S-Video or Video. (This is not the case for PC-Analog/PC-Digital/AV HDCP signals)	
Response	Acceptable	"000_%1" [CR]
	%1	"1080I60" ----- 1080i 60Hz "1080I50" ----- 1080i 50Hz "1035I". ----- 1035i "720P60" ----- 720p 60Hz "720P50" ----- 720p 50Hz "575P" ----- 575p "480P" ----- 480p "575I" ----- 575i (includes Composite signal such as PAL) "480I" ----- 480i (includes Composite signal such as NTSC) "NO_SIGNAL" ----- No signal
	Unacceptable	"101" [CR] --- When input signal is PC-Analog, PC-Digital or PC signals in AV HDCP "?" [CR]

9.7 Input Read Command

9.7.1 CR_INPUT Command

Command	"CR_INPUT" [CR]	
Details	Get selected INPUT No.	
Response	Acceptable	"000_%1" [CR]
	%1	"1 - 4"
	Unacceptable	"?" [CR]

9.7.2 CR_SOURCE Command

Command	"CR_SOURCE" [CR]	
Details	Get selected source	
Response	Acceptable	"000_%1" [CR]
	%1	"DIGITAL" ----- RGB (PC Digital) is selected "ANALOG" ----- RGB (PC Analog) is selected "SCART" ----- RGB (Scart) is selected "HDCP" ----- RGB (AV HDCP) is selected "VIDEO" ----- Video is selected "S-VIDEO" ----- S-Video is selected "YPBPR" ----- Y,Pb/Cb,Pr/Cr is selected "NETWORK" ----- Network is selected
	Unacceptable	"Error Code" [CR] --- When command is not available in the given condition (such as being selected input) "?" [CR] ----- When unknown command is received

9.7.3 CR_SRCINP1 Command

Command	"CR_SRCINP1" [CR]	
Details	Get Source of INPUT1	
Response	Acceptable	"000_%1" [CR]

	%1	"DIGITAL" ----- in PC Digital mode "ANALOG" ----- in PC Analog mode "SCART" ----- in Scart mode "HDCP" ----- in AV HDCP mode
	Unacceptable	"?" [CR]

9.7.4 CR_SRCINP2 Command

Command	"CR_SRCINP2" [CR]	
Details	Get Source of INPUT2	
Response	Acceptable	"000_%1" [CR]
	%1	"VIDEO" ----- in Video mode "YPBPR" ----- in Y,Pb/Cb,Pr/Cr mode "ANALOG" ----- in RGB mode
	Unacceptable	"?" [CR]

9.7.5 CR_SRCINP3 Command

Command	"CR_SRCINP3" [CR]	
Details	Get Source of INPUT3	
Response	Acceptable	"000_%1" [CR]
	%1	"VIDEO" ----- in Video mode "S-VIDEO" ----- in S-video mode "YPBPR" ----- in Y,Pb/Cb,Pr/Cr mode
	Unacceptable	"?" [CR]

9.7.6 CR_SRCINP4 Command

Command	"CR_SRCINP4" [CR]	
Details	Get Source of INPUT4	
Response	Acceptable	"000_%1" [CR]
	%1	"NETWORK" ----- With PJ-Net attached and the power ON
	Unacceptable	"101" [CR] ----- With PJ-Net attached and the power ON "103" [CR] ----- With PJ-Net unattached "?" [CR] ----- When unknown command is received.

9.7.7 CR_SYSTEM Command

Command	"CR_SYSTEM" [CR]	
Details	Get selected System	
Response	Acceptable	"000_%1" [CR]
	%1	Input is PC Analog "VGA1" ----- indicates VGA1 is selected "VGA2" ----- indicates VGA2 is selected : : : "XGA1" ----- indicates XGA1 is selected : "WXGA3" ----- indicates WXGA3 is selected "1080i" ----- indicates 1080i is selected "1035i" ----- indicates 1035i is selected "720p" ----- indicates 720p is selected "575p" ----- indicates 575p is selected "480p" ----- indicates 480p is selected "575i" ----- indicates 575i is selected "480i" ----- indicates 480i is selected

		<p>"1080PSF/24" ----- indicates 1080psf/24 is selected "1080PSF/25" ----- indicates 1080psf/25 is selected "1080PSF/30" ----- indicates 1080psf/30 is selected "MODE1" ----- indicates Mode1 is selected : : "MODE10" ----- indicates Mode10 is selected " EXT11" ----- indicates EXT11 is selected : : "EXT60" ----- indicates EXT60 is selected * Error Code "101" [CR] is returned for no signal</p>
	Input is PC-Digital/ AV-HDCP	<p>"D-XGA1" ----- indicates D-XGA1 is selected : "D-WXGA3" ----- indicates D-WXGA3 is selected "D-1080I" ----- indicates D-1080i is selected "D-1035I" ----- indicates D-1035i is selected "D-720P" ----- indicates D-720p is selected "D-575P" ----- indicates D-575p is selected "D-480P" ----- indicates D-480p is selected "D-575I" ----- indicates D-575i is selected "D-480I" ----- indicates D-480i is selected "D-1080PSF/24" ----- indicates D-1080psf/24 is selected "D-1080PSF/25" ----- indicates D-1080psf/25 is selected "D-1080PSF/30" ----- indicates D-1080psf/30 is selected * Error Code "101" [CR] is returned for no signal</p>
	Input is Y,Pb/Cb,Pr/Cr	<p>"AUTO" ----- indicates Auto is selected "1080I" ----- indicates 1080i is selected "1035I" ----- indicates 1035i is selected "720P" ----- indicates 720p is selected "575P" ----- indicates 575p is selected "480P" ----- indicates 480p is selected "575I" ----- indicates 575i is selected "480I" ----- indicates 480i is selected * Selected System is returned, whether or not signal is coming.</p>
	Input is Video or S-video	<p>"AUTO" ----- indicates Auto is selected "NTSC" ----- indicates NTSC is selected "NTSC443" ----- indicates NTSC4.43 is selected "PAL" ----- indicates PAL is selected "SECAM" ----- indicates SECAM is selected "PAL-M" ----- indicates PAL-M is selected "PAL-N" ----- indicates PAL-N is selected * Selected System is returned, whether or not signal is coming.</p>
	Unacceptable	"Error Code" [CR]

9.7.8 CR_SYSLIST Command

Command	"CR_SYSLIST" [CR]	
Details	Get possible systems for System list	
Response	Acceptable	"000_%1_%2_---_%X" [CR]
	%1	<p>Error Code "101" is returned for no signal. Otherwise following values are returned according to Source. When input is PC-Analog; "XGA1" ----- XGA1 is in the list "1080I" ----- 1080i is in the list "1080PSF/24" ----- 1080psf/24 is in the list "1080PSF/25" ----- 1080psf/25 is in the list "1080PSF/30" ----- 1080psf/30 is in the list * Auto, Mode1-10 shall not be returned. When input is PC-digital or AV-HDCP; "D-XGA" ----- D-XGA is in the list</p>

		<p>“D-720p” ----- D720p is in the list “D-1080PSF/24” ----- D1080psf/24 is in the list “D-1080PSF/25” ----- D1080psf/25 is in the list “D-1080PSF/30” ----- D1080psf/30 is in the list -When input is Y,Pb/Cb,Pr/Cr; All possible systems in Menu, including Auto, are returned; “AUTO” ----- Auto is in the list “1080i” ----- 1080i is in the list “1035i” ----- 1035i is in the list : “575i” ----- 575i is in the list “480i” ----- 480i is in the list -When input is Video or S-video; All possible systems in Menu, including Auto, are returned; “AUTO” ----- Auto is in the list “PAL” ----- PAL is in the list “SECAM” ----- SECAM is in the list : “PAL-N” ----- PAL-N is in the list</p>
	Unacceptable	“Error Code” [CR]

9.7.9 CR_MODELIST Command

Command	“CR_MODELIST” [CR]	
Details	Get possible modes for Mode list	
Response	Acceptable	“000_%1_%2_---_%x” [CR]
	%1	<p>Error Code “101” is returned except for PC-Analog and for no signal with PC-Analog Possible modes in Mode1-10 are returned when PC-Analog signal is coming.</p> <p>“MODE1” “MODE2” “MODE3” : : : “MODE8” “MODE9” “MODE10”</p>
	Unacceptable	“Error Code” [CR]

9.7.10 CR_HMSLOT Command

Command	“CR_HMSLOT” [CR]	
Details	Get the total number of Input.	
Response	Acceptable	“000_%1” [CR]
	%1	<p>“004” ----- When PJ-Net is attached. “003” ----- When PJ-Net is not attached.</p>
	Unacceptable	“Error Code” [CR]

9.7.11 CR_NMSLOT1 Command

Command	“CR_NMSLOT1” [CR]	
Details	Get terminal information of Input1	
Response	Acceptable	“000_%1” [CR]
	%1	“RGB”
	Unacceptable	“Error Code” [CR]

9.7.12 CR_NMSLOT2 Command

Command	"CR_NMSLOT2" [CR]	
Details	Get terminal information of Input2	
Response	Acceptable	"000_%1" [CR]
	%1	"5BNC"
	Unacceptable	"Error Code" [CR]

9.7.13 CR_NMSLOT3 Command

Command	"CR_NMSLOT3" [CR]	
Details	Get terminal information of Input3	
Response	Acceptable	"000_%1" [CR]
	%1	"VIDEO"
	Unacceptable	"Error Code" [CR]

9.7.14 CR_NMSLOT4 Command

Command	"CR_NMSLOT4" [CR]	
Details	Get terminal information of Input4	
Response	Acceptable	"000_%1" [CR]
	%1	"NETWORK" ----- When PJ-Net is attached. *With PJ-Net unattached, this command is invalid and error code "103" is returned. *With PJ-Net attached and the power OFF, error code "101" is returned. *In models not supporting PJ-Net, error code "103" is returned.
	Unacceptable	"Error Code" [CR]

9.7.15 CR_IDSLOT1 Command

Command	"CR_IDSLOT1" [CR]	
Details	Get ID information of Input1. This command is to determine sources possible to input.	
Response	Acceptable	"000_%1" [CR]
	%1	"30" ----- On-board (DVI-D and D-Sub) Available source: DIGITAL, ANALOG, SCART, HDCP, MONITOR OUT
	Unacceptable	"Error Code" [CR]

9.7.16 CR_IDSLOT2 Command

Command	"CR_IDSLOT2" [CR]	
Details	Get ID information of Input2. This command is to determine sources possible to input.	
Response	Acceptable	"000_%1" [CR]
	%1	"41" ----- On-board (5BNC) Available source: ANALOG, VIDEO, YPBPR
	Unacceptable	"Error Code" [CR]

9.7.17 CR_IDSLOT3 Command

Command	"CR_IDSLOT3" [CR]	
Details	Get ID information of Input3. This command is to determine sources possible to input.	
Response	Acceptable	"000_%1" [CR]
	%1	"51" ----- On-board (3BNC and S-VIDEO) Available source: VIDEO, S-VIDEO, YPBPR
	Unacceptable	"Error Code" [CR]

9.7.18 CR_IDSLOT4 Command

Command	"CR_IDSLOT4" [CR]	
Details	Get ID information of Input4. This command is to determine sources possible to input.	
Response	Acceptable	"000_%1" [CR]
	%1	"13" ----- PJ-Net (Viewer capable) Available source: Network *With PJ-Net unattached, this command is invalid and error code "103" is returned. *With PJ-Net attached and the power OFF, error code "101" is returned. *In models not supporting PJ-Net, error code "103" is returned.
	Unacceptable	"Error Code" [CR]

9.8 Screen Status Read Command

9.8.1 CR_SCREEN Command

Command	"CR_SCREEN" [CR]	
Details	Get selected screen image size	
Response	Acceptable	"000_%1" [CR]
	%1	"NORMAL" ----- Normal mode "WIDE" ----- Wide mode "FULL" ----- Full screen mode "TRUE" ----- True mode "CUSTOM" ----- Custom mode
	Unacceptable	"Error Code" [CR] --- When command is not available in the given condition (such as being selected input). "?" [CR] --- When unknown command is received

9.8.2 CR_VSCALE Command

Command	"CR_VSCALE" [CR]	
Details	Get setting status of V scale	
Response	Acceptable	"000_%1" [CR]
	%1	"-32" - "035"
	Unacceptable	"Error Code" [CR]

9.8.3 CR_VPOS Command

Command	"CR_VPOS" [CR]	
Details	Get setting status of V Position	

Response	Acceptable	"000_%1" [CR]
	%1	"-15" - "015"
	Unacceptable	"Error Code" [CR]

9.8.4 CR_HSCALE Command

Command	"CR_HSCALE" [CR]	
Details	Get setting status of H scale	
Response	Acceptable	"000_%1" [CR]
	%1	"-32" - "035"
	Unacceptable	"Error Code" [CR]

9.8.5 CR_HPOS Command

Command	"CR_HPOS" [CR]	
Details	Get setting status of H Position	
Response	Acceptable	"000_%1" [CR]
	%1	"-15" - "015"
	Unacceptable	"Error Code" [CR]

9.8.6 CR_KYSTNMODE Command

Command	"CR_KYSTNMODE" [CR]	
Details	Get setting status of Keystone Store Mode	
Response	Acceptable	"000_%1" [CR]
	%1	"STR" ----- Store mode is "Store" "RST" ----- Store mode is "Reset"
	Unacceptable	"?" [CR] ----- When unknown command is received

9.9 Lamp Status Read Command

9.9.1 CR_LAMPREPL Command

Command	"CR_LAMPREPL" [CR]	
Details	Get information of Lamp Replacement time	
Response	Acceptable	"000_%1" [CR]
	%1	"1Y" ----- indicates over lamp replacement time "1N" ----- indicates under lamp replacement time
	Unacceptable	"?" [CR]

9.9.2 CR_LAMPH Command

Command	"CR_LAMPH" [CR]	
Details	Get Lamp running time (in hours) * return actual lamp running time	
Response	Acceptable	"000_%1" [CR]
	%1	"00000 - 99999"
	Unacceptable	"Error Code" [CR]

9.9.3 CR_LAMPCORRESPH Command

Command	"CR_LAMPCORRESPH" [CR]	
Details	Get Lamp running time (in hours) *return lamp running time multiplied by a coefficient (not actual running time)	
Response	Acceptable	"000_%1" [CR]
	%1	"00000 – 99999"
	Unacceptable	"Error Code" [CR]

9.9.4 CR_LAMPMODE Command

Command	"CR_LAMPMODE" [CR]	
Details	Get setting status of Lamp mode	
Response	Acceptable	"000_%1" [CR]
	%1	"NORMAL" ----- Lamp mode is Normal status "ECO1" ----- Lamp mode is Eco1 status "ECO2" ----- Lamp mode is Eco2 status "AUTO" ----- Lamp mode is Auto status
	Unacceptable	"?" [CR]

9.9.5 CR_LAMPSTS Command

Command	"CR_LAMPSTS" [CR]	
Details	Get Lamp status	
Response	Acceptable	"000_%1" [CR]
	%1	"1I" ----- Lamp is ON "1O" ----- Lamp is OFF "1X" ----- Lamp Failure
	Unacceptable	"Error Code" [CR]

9.9.6 CR_PROJH Command

Command	"CR_PROJH" [CR]	
Details	Get total running time of Projector (in hours)	
Response	Acceptable	"000_%1" [CR]
	%1	"0000000 – 0099999"
	Unacceptable	"?" [CR]

9.9.7 CR_HMLAMP Command

Command	"CR_HMLAMP" [CR]	
Details	Get total lamp number	
Response	Acceptable	"000_%1" [CR]
	%1	"001"
	Unacceptable	"Error Code" [CR]

9.10 Setting Status Read Command

9.10.1 CR_BACKGND Command

Command	"CR_BACKGND" [CR]	
Details	Get setting status of Screen for no signal	
Response	Acceptable	"000_%1" [CR]
	%1	"BLUE" ----- Blue Back is selected "USER" ----- User is selected "BLACK" ----- Black Back is selected
	Unacceptable	"Error Code" [CR]

9.10.2 CR_DISP Command

Command	"CR_DISP" [CR]	
Details	Get setting status of Display	
Response	Acceptable	"000_%1" [CR]
	%1	"ON" ----- Display is ON "CNTDWN/OFF" ----- Count down is OFF "OFF" ----- Display is OFF
	Unacceptable	"?" [CR]

9.10.3 CR_LOGO Command

Command	"CR_LOGO" [CR]	
Details	Get setting status of Logo	
Response	Acceptable	"000_%1" [CR]
	%1	"DFLT" ----- Default Logo is enabled "USER" ----- User is enabled "OFF" ----- Logo is disabled
	Unacceptable	"?" [CR]

9.10.4 CR_LOGOLOCK Command

Command	"CR_LOGOLOCK" [CR]	
Details	Get setting status of Logo Lock function	
Response	Acceptable	"000_%1" [CR]
	%1	"ON" ----- Logo Lock is ON "OFF" ----- Logo Lock is OFF
	Unacceptable	"Error Code" [CR]

9.10.5 CR_CEIL Command

Command	"CR_CEIL" [CR]	
Details	Get setting status of Ceiling	
Response	Acceptable	"000_%1" [CR]
	%1	"ON" ----- Ceiling projection is enabled "OFF" ----- Ceiling projection is disabled
	Unacceptable	"Error Code" [CR]

9.10.6 CR_REAR Command

Command	"CR_REAR" [CR]	
Details	Get setting status of Rear function	
Response	Acceptable	"000_%1" [CR]
	%1	"ON" ----- Rear projection is enabled "OFF" ----- Rear projection is disabled
	Unacceptable	"Error Code" [CR]

9.10.7 CR_RCODE Command

Command	"CR_RCODE" [CR]	
Details	Get selected Remote Control Code	
Response	Acceptable	"000_%1" [CR]
	%1	"001" ----- Code 1 is selected "002" ----- Code 2 is selected "003" ----- Code 3 is selected "004" ----- Code 4 is selected "005" ----- Code 5 is selected "006" ----- Code 6 is selected "007" ----- Code 7 is selected "008" ----- Code 8 is selected
	Unacceptable	"?" [CR]

9.10.8 CR_RSENS Command

Command	"CR_RSENS" [CR]	
Details	Get selected location of infrared remote receiver of remote control	
Response	Acceptable	"000_%1" [CR]
	%1	"BOTH" ----- Select both front and back receiver of projector "FRONT" ----- Select only front receiver of projector "BACK" ----- Select only back receiver of projector
	Unacceptable	"?" [CR]

9.10.9 CR_RTYPE Command

Command	"CR_RTYPE" [CR]	
Details	Get status of supported Remote Control (IR/RF).	
Response	Acceptable	"000_%1" [CR]
	%1	"IR" ----- IR "RF" ----- RF (cannot be returned as this model supports only IR remote control)
	Unacceptable	"Error Code" [CR]

9.10.10 CR_LANG Command

Command	"CR_LANG" [CR]	
Details	Get selected language	
Response	Acceptable	"000_%1" [CR]
	%1	"ENG" ----- English is selected "DEU" ----- German is selected "FRA" ----- French is selected "ITA" ----- Italian is selected
	Unacceptable	"Error Code" [CR]

PLC-XP100L Expand Serial Command Functional Specifications

		"ESP" ----- Spanish is selected "POR" ----- Portuguese is selected "NED" ----- Dutch is selected "SVE" ----- Swedish is selected "JPN" ----- Japanese is selected "CHI" ----- Chinese is selected "KOR" ----- Korean is selected "RUS" ----- Russian is selected
	Unacceptable	"?" [CR]

9.10.11 CR_ON-STA Command

Command	"CR_ON-STA" [CR]	
Details	Get setting status of Power ON Start	
Response	Acceptable	"000_%1" [CR]
	%1	"ON" ----- Power ON Start is ON "OFF" ----- Power ON Start is OFF
	Unacceptable	"?" [CR]

9.10.12 CR_P-MANE Command

Command	"CR_P-MANE" [CR]	
Details	Get setting status of Power management	
Response	Acceptable	"000_%1" [CR]
	%1	"OFF" ----- Power Management is disabled "READY" ----- Power Management is set to Ready "SHUTDOWN" ----- Power Management is set to Shut Down mode
	Unacceptable	"?" [CR]

9.10.13 CR_P-MANETIME Command

Command	"CR_P-MAETIME" [CR]	
Details	Get setting time for starting Power Management function	
Response	Acceptable	"000_%1" [CR]
	%1	"001 – 030" ----- 1 to 30 minutes
	Unacceptable	"?" [CR]

9.10.14 CR_FANSPEED Command

Command	"CR_FANSPEED" [CR]	
Details	Get selected Fan Control Speed mode.	
Response	Acceptable	"000_%1" [CR]
	%1	"MAX" ----- Max mode is selected "NOR" ----- Normal mode is selected
	Unacceptable	"?" [CR]

9.10.15 CR_KEYDIS Command

Command	"CR_KEYDIS" [CR]	
Details	Get status of RC/KEY (valid or invalid)	
Response	Acceptable	"000_%1" [CR]

	%1	"NONE" ----- RC and KEY, both are valid "RC" ----- RC is invalid "KEY" ----- KEY is invalid
	Unacceptable	"?" [CR]

9.10.16 CR_SECURITY Command

Command	"CR_SECURITY" [CR]	
Details	Get ON/OFF setting status of Security on menu.	
Response	Acceptable	"000_%1" [CR]
	%1	"ON" ----- PJ is locked "OFF" ----- PJ is not locked.
	Unacceptable	"Error Code" [CR]

9.10.17 CR_PJLOCKNOW Command

Command	"CR_PJLOCKNOW" [CR]	
Details	Get actual setting status of PIN code lock	
Response	Acceptable	"000_%1" [CR]
	%1	"LOCK" ----- PJ is locked PIN code lock is set to ON1/ON2 on the menu and PJ PIN code is not entered, therefore PJ is actually locked. "FREE" ----- PJ is unlocked (either A or B) A) PJ lock is set to OFF on the menu B) PJ lock is set to ON1/ON2 on the menu, but PIN code Lock mode is canceled because PJ PIN code is entered.
	Unacceptable	"Error Code" [CR]

9.10.18 CR_PJLOCKMENU Command

Command	"CR_PJLOCKMENU" [CR]	
Details	Get ON/OFF setting status of PIN code lock on menu	
Response	Acceptable	"000_%1" [CR]
	%1	"ON1" ----- PIN code lock ON 1 is set on the menu "ON2" ----- PIN code lock ON 2 is set on the menu "OFF" ----- PIN code lock OFF is set on the menu
	Unacceptable	"Error Code" [CR]

9.10.19 CR_TESTPAT Command

Command	"CR_TESTPAT" [CR]	
Details	Get setting status of Test pattern	
Response	Acceptable	"000_%1" [CR]
	%1	"COLOR" ----- Color bar is displayed "GRAD1" ----- 16step(white→black) is displayed "GRAD2" ----- 16step(white←black) is displayed "GRAD3" ----- 16step(white↓black) is displayed "GRAD4" ----- 16step(white↑black) is displayed "WHITE" ----- All white is displayed "BALCK" ----- All black is displayed "CROSS" ----- Cross is displayed "OFF" ----- Test pattern diplay is not displayed
	Unacceptable	"Error Code" [CR]

9.10.20 **CR_FILH Command**

Command	"CR_FILH" [CR]	
Details	Get Filter used time	
Response	Acceptable	"000_%1" [CR]
	%1	"00000 - 99999"
	Unacceptable	"Error Code" [CR]

9.10.21 **CR_FILCOND Command**

Command	"CR_FILCOND" [CR]	
Details	Get status of filter clog	
Response	Acceptable	"000_%1" [CR]
	%1	"CLOG" = Filter is clogged "WARN" = Filter is nearly clogged "CLEAN" = Filter is not clogged
	Unacceptable	"Error Code" [CR]

9.10.22 **CR_FILREPL Command**

Command	"CR_FILREPL" [CR]	
Details	Get status of Filter cleaning / replacement time	
Response	Acceptable	"000_%1" [CR]
	%1	"1Y"-----Filter Exchange time is over value of Filter Message. "1N"--Filter Exchange time is not over value of Filter Message.
	Unacceptable	"Error Code" [CR]

9.10.23 **CR_FILTIMER Command**

Command	"CR_FILTIMER" [CR]	
Details	Get Filter used time	
Response	Acceptable	"000_%1" [CR]
	%1	"0400" ----- Display message by 400h used. "0700" ----- Display message by 700h used. "1000" ----- Display message by 1000h used. "OFF" ----- Off(Warning display is not displayed)
	Unacceptable	"Error Code" [CR]

9.10.24 **CR_FILREMAIN Command**

Command	"CR_FILREMAIN" [CR]	
Details	Get remaining number of usable Filter scroll	
Response	Acceptable	"000_%1" [CR]
	%1	"09" = Remaining number of usable Filter scroll : 9 times "00" = Remaining number of usable Filter scroll : 0 time
	Unacceptable	"Error Code" [CR]

9.10.25 **CR_POINTER Command**

Command	"CR_POINTER" [CR]	
Details	Get setting status of Pointer	

Response	Acceptable	"000_%a" [CR]
	%1	"ARROW" -----Arrow Pointer mode "FINGER" -----Finger Pointer mode "LASER" ----- Laser mark Pointer modr
	Unacceptable	"Error Code" [CR]

9.11 Other Status Read Commands

9.11.1 CR_STATUS Command

COMMAND	"CR_STATUS" [CR]	
Detail	Get operating status of Projector Same as "CR0" in basic command except error code follows it.	
Response	Acceptable	"000_%1" [CR]
	%1	"00" = Power ON "80" = Standby "40" = Countdown in process "20" = Cooling Down in process "10" = Power Failure "28" = Cooling Down in process due to abnormal temperature "88" =Standby after Cooling Down due to abnormal temperature "02" = Invalid RS-232C Command "24" = Power Save/Cooling Down in process "04" = Power Save "21" = Cooling Down in process after turedn Off due to lamp failure "81" = Standby after Cooling Down due to lamp failure
	Unacceptable	"Error Code" [CR]

9.11.2 CR_PRESSURE Command

Command	"CR_PRESSURE" [CR]	
Details	Get value from Air Pressure sensor. Flowing is the formula to work out Air Pressure from the given value ("Vn" represents the value): Air Pressure (hPa) = (5*Vn / 1024 - 0.204) / 0.00459 + 150 Obtains accuracy of +/- 2%	
Response	Acceptable	"000_%1" [CR]
	%1	"0000" – "1023"
	Unacceptable	"Error Code" [CR]

9.11.3 CR_SIGNAL Command

Command	"CR_SIGNAL" [CR]	
Details	Get status whether there is any signal or not.	
Response	Acceptable	"000_%1" [CR]
	%1	"ON" ----- There is signal "OFF" ----- There is no signal
	Unacceptable	"?" [CR]

9.11.4 CR_VMUTE Command

Command	"CR_VMUTE" [CR]	
Details	Get setting status of No Show.	

PLC-XP100L Expand Serial Command Functional Specifications

Response	Acceptable	"000_%1" [CR]
	%1	"ON" ----- No show is enabled "OFF" ----- No show is disabled
	Unacceptable	"?" [CR]

9.11.5 CR_FREEZE Command

Command	"CR_FREEZE" [CR]	
Details	Get setting status of Freeze.	
Response	Acceptable	"000_%1" [CR]
	%1	"ON" ----- Freeze is enabled "OFF" ----- Freeze is disabled
	Unacceptable	"?" [CR]

9.11.6 CR_ALLPFAIL Command

Command	"CR_ALLPFAIL" [CR]	
Details	Get all the information on Power Failure Return all the responses of "CR_PFAIL01" – "PFAIL27" at once Therefore it consists of 648 (24 bytes x 27) bytes totally	
Response	Acceptable	"000_%1_%2" [CR] "000_%3_%4" [CR] "000_%5_%6" [CR] ⋮ ⋮ "000_%97_%98" [CR] "000_%99_%100" [CR] (Send all 50 blocks above at one time)
	%1 - %100	%1, %3, ●●%99 (Odd number) ----- Item name of Power Failure (16-byte fixed length) %2, %4, ●●%100 (Even number) ----- Power status (2-byte fixed length) Power is failed: "NG" Power status is normal: "OK"
	Unacceptable	"Error Code" [CR]

9.11.7 CR_HMPFAIL Command

Command	"CR_HMPFAIL" [CR]	
Details	Get total number of detectable Power Failure	
Response	Acceptable	"000_%1" [CR]
	%1	"000 – 027"
	Unacceptable	"Error Code" [CR]

9.11.8 CR_PFAIL01 Command

Command	"CR_PFAIL01" [CR]	
Details	Get item name and status of Power Failure No.1	
Response	Acceptable	"000_%1_%2" [CR]
	%1	%1 ----- Item name of Power Failure (16-byte fixed length) %2 ----- Power status (2-byte fixed length) Power is failed: "NG" Power status is normal: "OK"

	Unacceptable	"Error Code" [CR]
--	--------------	-------------------

9.11.9 CR_PFAIL02 Command

Command	"CR_PFAIL02" [CR]	
Details	Get the item name and status of Power Failure No.2	
Response	Acceptable	"000_%1_%2" [CR]
	%1	%1 ----- Item name of Power Failure (16-byte fixed length) %2 ----- Power status (2-byte fixed length) Power is failed: "NG" Power status is normal: "OK"
	Unacceptable	"Error Code" [CR]

9.11.10 CR_PFAIL03 Command

Command	"CR_PFAIL03" [CR]	
Details	Get the item name and status of Power Failure No.3	
Response	Acceptable	"000_%1_%2" [CR]
	%1	%1 ----- Item name of Power Failure (16-byte fixed length) %2 ----- Power status (2-byte fixed length) Power is failed: "NG" Power status is normal: "OK"
	Unacceptable	"Error Code" [CR]

9.11.11 CR_PFAIL04 Command

Command	"CR_PFAIL04" [CR]	
Details	Get the item name and status of Power Failure No.4	
Response	Acceptable	"000_%1_%2" [CR]
	%1	%1 ----- Item name of Power Failure (16-byte fixed length) %2 ----- Power status (2-byte fixed length) Power is failed: "NG" Power status is normal: "OK"
	Unacceptable	"Error Code" [CR]

9.11.12 CR_PFAIL05 Command

Command	"CR_PFAIL05" [CR]	
Details	Get the item name and status of Power Failure No.5	
Response	Acceptable	"000_%1_%2" [CR]
	%1	%1 ----- Item name of Power Failure (16-byte fixed length) %2 ----- Power status (2-byte fixed length) Power is failed: "NG" Power status is normal: "OK"
	Unacceptable	"Error Code" [CR]

9.11.13 CR_PFAIL06 Command

Command	"CR_PFAIL06" [CR]	
Details	Get the item name and status of Power Failure No.6	
Response	Acceptable	"000_%1_%2" [CR]
	%1	%1 ----- Item name of Power Failure (16-byte fixed length)

PLC-XP100L Expand Serial Command Functional Specifications

		%2 ----- Power status (2-byte fixed length) Power is failed: "NG" Power status is normal: "OK"
	Unacceptable	"Error Code" [CR]

9.11.14 CR_PFAIL07 Command

Command	"CR_PFAIL07" [CR]	
Details	Get the item name and status of Power Failure No.7	
Response	Acceptable	"000_%1_%2" [CR]
	%1	%1 ----- Item name of Power Failure (16-byte fixed length) %2 ----- Power status (2-byte fixed length) Power is failed: "NG" Power status is normal: "OK"
	Unacceptable	"Error Code" [CR]

9.11.15 CR_PFAIL08 Command

Command	"CR_PFAIL08" [CR]	
Details	Get the item name and status of Power Failure No.8	
Response	Acceptable	"000_%1_%2" [CR]
	%1	%1 ----- Item name of Power Failure (16-byte fixed length) %2 ----- Power status (2-byte fixed length) Power is failed: "NG", Power status is normal: "OK"
	Unacceptable	"Error Code" [CR]

9.11.16 CR_PFAIL09 Command

Command	"CR_PFAIL09" [CR]	
Details	Get the item name and status of Power Failure No.9	
Response	Acceptable	"000_%1_%2" [CR]
	%1	%1 ----- Item name of Power Failure (16-byte fixed length) %2 ----- Power status (2-byte fixed length) Power is failed: "NG", Power status is normal: "OK"
	Unacceptable	"Error Code" [CR]

9.11.17 CR_PFAIL10 Command

Command	"CR_PFAIL10" [CR]	
Details	Get the item name and status of Power Failure No.10	
Response	Acceptable	"000_%1_%2" [CR]
	%1	%1 ----- Item name of Power Failure (16-byte fixed length) %2 ----- Power status (2-byte fixed length) Power is failed: "NG", Power status is normal: "OK"
	Unacceptable	"Error Code" [CR]

9.11.18 CR_PFAIL11 Command

Command	"CR_PFAIL11" [CR]	
Details	Get the item name and status of Power Failure No.11	
Response	Acceptable	"000_%1_%2" [CR]

	%1	%1 ----- Item name of Power Failure (16-byte fixed length) %2 ----- Power status (2-byte fixed length) Power is failed: "NG", Power status is normal: "OK"
	Unacceptable	"Error Code" [CR]

9.11.19 CR_PFAIL12 Command

Command	"CR_PFAIL12" [CR]	
Details	Get the item name and status of Power Failure No.12	
Response	Acceptable	"000_%1_%2" [CR]
	%1	%1 ----- Item name of Power Failure (16-byte fixed length) %2 ----- Power status (2-byte fixed length) Power is failed: "NG", Power status is normal: "OK"
	Unacceptable	"Error Code" [CR]

9.11.20 CR_PFAIL13 Command

Command	"CR_PFAIL13" [CR]	
Details	Get the item name and status of Power Failure No.13	
Response	Acceptable	"000_%1_%2" [CR]
	%1	%1 ----- Item name of Power Failure (16-byte fixed length) %2 ----- Power status (2-byte fixed length) Power is failed: "NG", Power status is normal: "OK"
	Unacceptable	"Error Code" [CR]

9.11.21 CR_PFAIL14 Command

Command	"CR_PFAIL14" [CR]	
Details	Get the item name and status of Power Failure No.14	
Response	Acceptable	"000_%1_%2" [CR]
	%1	%1 ----- Item name of Power Failure (16-byte fixed length) %2 ----- Power status (2-byte fixed length) Power is failed: "NG", Power status is normal: "OK"
	Unacceptable	"Error Code" [CR]

9.11.22 CR_PFAIL15Command

Command	"CR_PFAIL15" [CR]	
Details	Get the item name and status of Power Failure No.15	
Response	Acceptable	"000_%1_%2" [CR]
	%1	%1 ----- Item name of Power Failure (16-byte fixed length) %2 ----- Power status (2-byte fixed length) Power is failed: "NG", Power status is normal: "OK"
	Unacceptable	"Error Code" [CR]

9.11.23 CR_PFAIL16 Command

Command	"CR_PFAIL16" [CR]	
Details	Get the item name and status of Power Failure No.16	
Response	Acceptable	"000_%1_%2" [CR]
	%1	%1 ----- Item name of Power Failure (16-byte fixed length)

PLC-XP100L Expand Serial Command Functional Specifications

		%2 ----- Power status (2-byte fixed length) Power is failed: "NG", Power status is normal: "OK"
	Unacceptable	"Error Code" [CR]

9.11.24 CR_PFAIL17 Command

Command	"CR_PFAIL17" [CR]	
Details	Get the item name and status of Power Failure No.17	
Response	Acceptable	"000_%1_%2" [CR]
	%1	%1 ----- Item name of Power Failure (16-byte fixed length) %2 ----- Power status (2-byte fixed length) Power is failed: "NG", Power status is normal: "OK"
	Unacceptable	"Error Code" [CR]

9.11.25 CR_PFAIL18 Command

Command	"CR_PFAIL18" [CR]	
Details	Get the item name and status of Power Failure No.18	
Response	Acceptable	"000_%1_%2" [CR]
	%1	%1 ----- Item name of Power Failure (16-byte fixed length) %2 ----- Power status (2-byte fixed length) Power is failed: "NG", Power status is normal: "OK"
	Unacceptable	"Error Code" [CR]

9.11.26 CR_PFAIL19 Command

Command	"CR_PFAIL19" [CR]	
Details	Get the item name and status of Power Failure No.19	
Response	Acceptable	"000_%1_%2" [CR]
	%1	%1 ----- Item name of Power Failure (16-byte fixed length) %2 ----- Power status (2-byte fixed length) Power is failed: "NG", Power status is normal: "OK"
	Unacceptable	"Error Code" [CR]

9.11.27 CR_PFAIL20 Command

Command	"CR_PFAIL20" [CR]	
Details	Get the item name and status of Power Failure No.20	
Response	Acceptable	"000_%1_%2" [CR]
	%1	%1 ----- Item name of Power Failure (16-byte fixed length) %2 ----- Power status (2-byte fixed length) Power is failed: "NG", Power status is normal: "OK"
	Unacceptable	"Error Code" [CR]

9.11.28 CR_PFAIL21 Command

Command	"CR_PFAIL21" [CR]	
Details	Get the item name and status of Power Failure No.21	
Response	Acceptable	"000_%1_%2" [CR]
	%1	%1 ----- Item name of Power Failure (16-byte fixed length) %2 ----- Power status (2-byte fixed length)

		Power is failed: "NG", Power status is normal: "OK"
	Unacceptable	"Error Code" [CR]

9.11.29 CR_PFAIL22 Command

Command	"CR_PFAIL22" [CR]	
Details	Get the item name and status of Power Failure No.22	
Response	Acceptable	"000_%1_%2" [CR]
	%1	%1 ----- Item name of Power Failure (16-byte fixed length) %2 ----- Power status (2-byte fixed length) Power is failed: "NG", Power status is normal: "OK"
	Unacceptable	"Error Code" [CR]

9.11.30 CR_PFAIL23 Command

Command	"CR_PFAIL23" [CR]	
Details	Get the item name and status of Power Failure No.23	
Response	Acceptable	"000_%1_%2" [CR]
	%1	%1 ----- Item name of Power Failure (16-byte fixed length) %2 ----- Power status (2-byte fixed length) Power is failed: "NG", Power status is normal: "OK"
	Unacceptable	"Error Code" [CR]

9.11.31 CR_PFAIL24 Command

Command	"CR_PFAIL24" [CR]	
Details	Get the item name and status of Power Failure No.24	
Response	Acceptable	"000_%1_%2" [CR]
	%1	%1 ----- Item name of Power Failure (16-byte fixed length) %2 ----- Power status (2-byte fixed length) Power is failed: "NG", Power status is normal: "OK"
	Unacceptable	"Error Code" [CR]

9.11.32 CR_PFAIL25 Command

Command	"CR_PFAIL25" [CR]	
Details	Get the item name and status of Power Failure No.25	
Response	Acceptable	"000_%1_%2" [CR]
	%1	%1 ----- Item name of Power Failure (16-byte fixed length) %2 ----- Power status (2-byte fixed length) Power is failed: "NG", Power status is normal: "OK"
	Unacceptable	"Error Code" [CR]

9.11.33 CR_PFAIL26 Command

Command	"CR_PFAIL26" [CR]	
Details	Get the item name and status of Power Failure No.26	
Response	Acceptable	"000_%1_%2" [CR]
	%1	%1 ----- Item name of Power Failure (16-byte fixed length) %2 ----- Power status (2-byte fixed length) Power is failed: "NG", Power status is normal: "OK"

	Unacceptable	"Error Code" [CR]
--	--------------	-------------------

9.11.34 CR_PFAIL27 Command

Command	"CR_PFAIL27" [CR]	
Details	Get the item name and status of Power Failure No.27	
Response	Acceptable	"000_%1_%2" [CR]
	%1	%1 ----- Item name of Power Failure (16-byte fixed length) %2 ----- Power status (2-byte fixed length) Power is failed: "NG", Power status is normal: "OK"
	Unacceptable	"Error Code" [CR]

9.11.35 CR_TEMPFAIL Command

Command	"CR_TEMPFAIL" [CR]	
Details	Get the temperature inside a projector when abnormal temperature status occurs. It is possible to get the temperatures all at once when several sensors installed.	
Response	Acceptable	"000_%1_%2_%3" [CR]
	%1,%2,%3	<p>%1 ----- Sensor 1 temp. %2 ----- Sensor 2 temp. %3 ----- Sensor 3 temp. e.g. "_31.5F" "_" indicates a space. When the temperature goes under 0, the first character is "-", not a space, as in "-05.5F". With more than one temperature sensors installed, projector returns responses in a row. e.g. "_31.5F _35.2S _38.0W" [CR] The first data indicates sensor 1 data, then one space, and sensor 2 data. Last character in each data indicates the sensor's status. "F" ----- Exceeding critical temp. (abnormal temp.) "W" ----- Approaching critical temp. (Warning temp.) "S" ----- Sensor temp. is safe (Safe temp.) "N" ----- Sensor detects no critical temp. "E" ----- Unable to return the temp. data</p> <p>The example 1 shows that sensor 1 indicates 31.5 degrees and the temperature is abnormal, sensor 2 indicates 35.2 degrees and the temperature is safe, sensor 3 indicates 38.0 degrees and the temperature is approaching critical state. When the temperature is safe, all data is represented as "_00.0S". When the projector is reset, "_00.0S" is set, and every time abnormal temperature occurs, it renews the data and returns it. In short, it only returns the renewed data of the latest abnormal temperature and the previous data is deleted.</p>
	Unacceptable	"?" [CR]

9.11.36 CR_TEMP Command

Command	"CR_TEMP" [CR]	
Details	Get the current temperature information inside a projector. It is possible to get the temperatures all at once when several sensors installed.	
Response	Acceptable	"000_%1_%2_%3" [CR]
	%1, %2, %3	<p>%1 ----- Sensor 1 temp. (External temp.) %2 ----- Sensor 2 temp. (Internal temp.1) %3 ----- Sensor 3 temp. (Internal temp.2) %1, %2 are fixed 6 characters</p>

PLC-XP100L Expand Serial Command Functional Specifications

		<p>There is one space between %1 and %2 There is one space between %2 and %3 e.g. "_31.5F"] "_" indicates a space. When the temperature goes under 0, the first character is "-", not a space, as in "-05.5F". Last character in each data indicates the sensor's status. "F" ----- Exceeding critical temp. (abnormal temp.) "W" ----- Approaching critical temp. (Warning temp.) "S" ----- Sensor temp. is safe (Safe temp.) "N" ----- Sensor detects no critical temp. "E" ----- Unable to return the temp. data</p> <p>With more than one temperature sensors installed, projector returns responses in a row. e.g. "_31.5F __35.2S __38.0W " [CR] The first data indicates sensor 1 data, then one space, and sensor 2 data.</p> <p>The example 1 shows that sensor 1 indicates 31.5 degrees and the temperature is abnormal, sensor 2 indicates 35.2 degrees and the temperature is safe, sensor 3 indicates 38.0 degrees and the temperature is approaching critical state. When it cannot return the temperature data due to hardware error, the last character is "E" as in "_00.0E" It might happen for some projectors that the temperature continues to go up to abnormal status as long as lamp ballasts are hot. Therefore when in StandBy mode or for several tens of seconds after Power is ON, any treatment of Power Failure is not processed. In that case, the temperature data is represented as "_ - - - N".</p>
	Unacceptable	"Error Code" [CR]