

EXPAND SERIAL COMMAND

FUNCTIONAL SPECIFICATIONS

PLC-XL50

Ver. 1.00

CONTENTS

1. OverView	7
2. Serial Interface Specification	7
2.1 Transfer Specification	7
2.2 Connection	7
3. Notes for communication.....	8
4. Name Definition.....	8
5. Functional Execution Command Table.....	9
5.1 Image Command Table.....	9
5.2 PC Adjust Control Command Table.....	9
5.3 Input Control Command Table	9
5.4 Screen Command Table	9
5.5 Lamp Command Table.....	10
5.6 Sound Command Table.....	10
5.7 Setting Command Table.....	10
6. Status Read Command Table.....	11
6.1 Image Status Read Command Table.....	11
6.2 PC Adjust Status Read Command Table	11
6.3 Video Status Read Command Table.....	11
6.4 Input Status Read Command Table.....	11
6.5 Screen Status Read Command Table	11
6.6 Lamp Status Read Command Table.....	12
6.7 Sound Status Read Command Table.....	12
6.8 Setting Status Read Command Table.....	12
6.9 Other Status Read Command	12
7. Error Code Table	13
8. Functional Execution Command	14
8.1 Format	14
8.2 Transfer Example	14
8.3 Operation Requirements.....	14
8.4 Image Command.....	15
8.4.1 CF_BRIGHT Command	15
8.4.2 CF_CONT Command	15
8.4.3 CF_COLOR Command	15
8.4.4 CF_TINT Command	16
8.4.5 CF_SHARP Command.....	16
8.4.6 CF_GAMMA Command	16
8.4.7 CF_WBAL - Command	17
8.4.8 CF_COLTEMP Command.....	17
8.4.9 CF_PROGV Command	17

8.4.10	CF_NZRED Command	18
8.4.11	CF_IMAGE Command	18
8.4.12	CF_IMAGEADJ Command	18
8.5	PC Adjust Control Command	19
8.5.1	CF_FSYNC Command	19
8.5.2	CF_TDOTS Command	19
8.5.3	CF_CLAMP Command.....	19
8.5.4	CF_H – POS Command	20
8.5.5	CF_V – POS Command	20
8.5.6	CF_DDOTS Command.....	20
8.5.7	CF_DLINE Command	21
8.5.8	CF_PCSTORE Command.....	21
8.5.9	CF_PCMODEFREE Command.....	21
8.6	Input Control Command.....	22
8.6.1	CF_INPUT Command (Network mode is not available).....	22
8.6.2	CF_SOURCE Command	22
8.6.3	CF_INPUT_%1_%2 Command	22
8.6.4	CF_SYSTEM Command	23
8.7	Screen Control Command	24
8.7.1	CF_SCREEN Command	24
8.7.2	CF_DZCENT Command.....	24
8.7.3	CF_KEYSTONE Command	24
8.7.4	CF_KYSTNMODE Command	24
8.8	Lamp Command	25
8.8.1	CF_LAMPH Command	25
8.8.2	CF_LAMPMODE Command	25
8.9	Sound Command	26
8.9.1	CF_VOLUME Command.....	26
8.9.2	CF_MUTE Command	26
8.10	Setting Command	27
8.10.1	CF_BBACK Command	27
8.10.2	CF_DISP Command.....	27
8.10.3	CF_LOGO Command.....	27
8.10.4	CF_CEIL Command	27
8.10.5	CF_REAR Command	28
8.10.6	CF_RCODE Command	28
8.10.7	CF_LANG Command	28
8.10.8	CF_ZOOM Command	29
8.10.9	CF_INPUTSEARCH Command	29
8.10.10	CF_ON – STA Command	29

8.10.11	CF_P – MANE Command.....	29
8.10.12	CF_P – MANETIME Command.....	30
8.10.13	CF_FANSPEED Command	30
8.10.14	CF_KEYDIS Command	30
8.10.15	CF_TERMINAL Command	30
8.10.16	CF_FDEFAULT Command	30
8.10.17	CF_LOGOCAPTURE Command	31
8.10.18	CF_FANMODE Command.....	31
8.10.19	CF_UNIFORMITY Command	31
8.10.20	CF_FILTIMER Command	31
8.10.21	CF_FANMODE Command.....	32
9.	Status Read Command.....	33
9.1	Format	33
9.2	Transfer Example	33
9.3	Operation Condition	33
9.4	Image Status Read Command	34
9.4.1	CR_BRIGHT Command	34
9.4.2	CR_CONT Command.....	34
9.4.3	CR_COLOR Command	34
9.4.4	CR_TINT Command.....	34
9.4.5	CR_SHARP Command	34
9.4.6	CR_GAMMA Command	35
9.4.7	CR_WBAL – R Command	35
9.4.8	CR_WBAL – G Command	35
9.4.9	CR_WBAL – B Command	35
9.4.10	CR_COLTEMP Command.....	35
9.4.11	CR_NZRED Command	36
9.4.12	CR_PROGV Command.....	36
9.4.13	CR_IMAGE Command	36
9.4.14	CR_IMGGMD Command.....	36
9.5	PC Adjust Status Read Command	37
9.5.1	CR_FSYNC Command.....	37
9.5.2	CR_TDOTS Command.....	37
9.5.3	CR_CLAMP Command	37
9.5.4	CR_H – POS Command.....	37
9.5.5	CR_V – POS Command.....	38
9.5.6	CR_DDOTS Command	38
9.5.7	CR_DLINE Command	38
9.5.8	CR_PCSTORE Command	38
9.5.9	CR_SETPCADJ Command.....	39

9.6	Video Status Read Command	40
9.6.1	CR_SERSYS Command	40
9.7	Input Status Read Command	41
9.7.1	CR_INPUT Command	41
9.7.2	CR_SOURCE Command	41
9.7.3	CR_INPUT_%1 Command	41
9.7.4	CR_SYSTEM Command	42
9.8	Screen Status Read Command	43
9.8.1	CR_SCREEN Command	43
9.8.2	CR_FLSCREEN Command	43
9.8.3	CR_TRUE Command	43
9.8.4	CR_KYSTNMODE Command	43
9.9	Lamp Status Read Command	44
9.9.1	CR_LAMPREPL Command	44
9.9.2	CR_LAMPMODE Command	44
9.9.3	CR_PROJH Command	44
9.10	Sound Status Read Command	45
9.10.1	CR_VOLUME Command	45
9.10.2	CR_MUTE Command	45
9.11	Setting Status Read Command	46
9.11.1	CR_BBACK Command	46
9.11.2	CR_DISP Command	46
9.11.3	CR_LOGO Command	46
9.11.4	CR_CEIL Command	46
9.11.5	CR_REAR Command	46
9.11.6	CR_RCODE Command	47
9.11.7	CR_LANG Command	47
9.11.8	CR_ZOOM Command	47
9.11.9	CR_INPUTSEARCH Command	47
9.11.10	CR_ON-STA Command	48
9.11.11	CR_P-MANE Command	48
9.11.12	CR_P – MANETIME Command	48
9.11.13	CR_FANSPEED Command	48
9.11.14	CR_TERMINAL Command	48
9.11.15	CR_FANMODE Command	49
9.11.16	CR_UNIFORMITY Command	49
9.11.17	CR_FILH Command	49
9.11.18	CR_FILREPL Command	49
9.11.19	CR_FILTIMER Command	49
9.12	Other Status Read Command	50

9.12.1	CR_SIGNAL Command	50
9.12.2	CR_VMUTE Command	50
9.12.3	CR_FREEZE Command.....	50
9.12.4	CR_PTIMER Command	50
9.12.5	CR_TEMPWARN Command.....	50
9.12.6	CR_TEMPFAIL Command.....	51

1. Overview

1.1 This Functional specification defines communication functions for PLC-XL50.

1.2 Compatible to Firmware Ver. 1.x of the projector.

2. Serial Interface Specification

2.1 Transfer Specification

Item	Specification
Synchronous System	Asynchronous
Transmission Speed	9600 / 19200
Data Length	8 bit
Parity	N/A
Stop Bit	1
Flow Control	N/A

Note1) Transmission Speed : initial setting value is 19200

Note2) Transmission Speed can be changed in service mode.

2.2 Connection

Dedicated serial cable must be used for a connection to a computer and a projector.

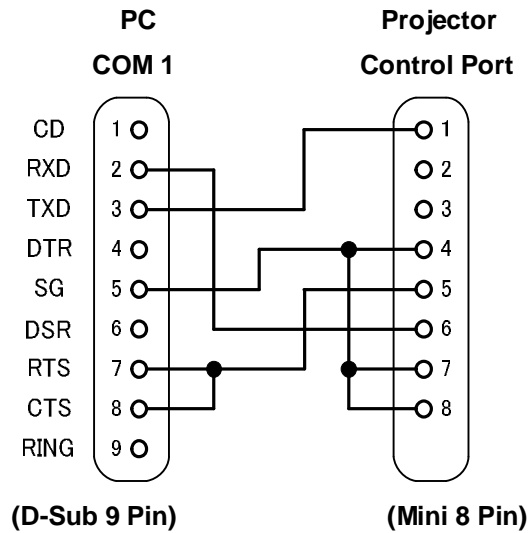

3. Notes for communication

3.1 Expand Serial Command is defined as one command / one line that starts with "C" and ends with carriage return (0x0D)

3.2 There are two types of commands: Functional Execution Command and Status Read Command.

- Example of Functional Execution Command: "CF_BRIGHT_032"[CR]

- Example of Status Read Command: "CR_RIGHT"[CR]

- Example of Control Switch Command: "PF_LANMODE_1"[CR]

Note) " _ " means a space

3.3 When it takes more than one second to receive one command, it is not executed.

When it takes more than one second to receive carriage return (0X0D) since the projector has received the first data "C", it clears the information of buffer.

3.4 When the command pipelining, it must wait for 100ms till sending next command after the response.

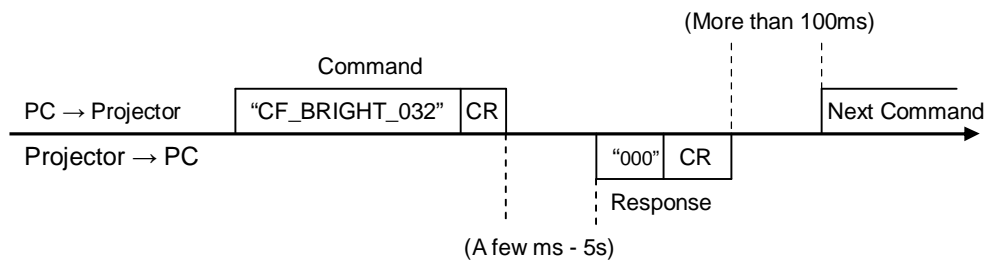

3.4.1 When a computer sends next command before receiving a response, the projector may not operate properly.

3.4.2 Except when there is no response for more than 5 seconds.

3.5 It takes about 5 seconds for internal initialization after plugging in AC power. During this time it cannot process commands. Do not issue any command.

4. Name Definition

4.1 Data from a controller to a projector is represented as COMMAND, and data from a projector to a controller for the incoming command is represented as RESPONSE.

4.2 [CR] : Carriage Return Code

Command ends with carriage return code.

Response command also ends with carriage return code.

4.3 _ : Space Code

All space Code is indicated by (_).

4.4 %1 : Parameter in Command

When there are some parameters, they are defined as %2, %3...

4.5 %%% : Error code returned from a projector

Acceptable: "000".

Unacceptable: See [7. Error Code Table].

4.6 %a : Parameter in Response Command

When there are some parameters, they are defined as %b, %c...

5. Functional Execution Command Table

5.1 Image Command Table

Execute command	Item
CF_BRIGHT_%1[CR]	Set Brightness value
CF_CONT_%1[CR]	Set Contrast value
CF_COLOR_%1[CR]	Set Color value
CF_TINT_%1[CR]	Set Tint value
CF_SHARP_%1[CR]	Set Sharpness value
CF_GAMMA_%1[CR]	Set Gamma value
CF_WBAL-R_%1[CR]	Set White Balance Red value
CF_WBAL-G_%1[CR]	Set White Balance Green value
CF_WBAL-B_%1[CR]	Set White Balance Blue value
CF_COLTEMP_%1[CR]	Set Color Temp. value
CF_NZRED_%1[CR]	Set/Cancel Noise reduction
CF_PROGV_%1[CR]	Set /Cancel Progressive Scan
CF_IMAGE_%1[CR]	Set Image mode
CF_IMAGEADJ_%1[CR]	Reset/Store for Image Adjustment

5.2 PC Adjust Control Command Table

Execute command	Item
CF_FSYNC_%1[CR]	Set Fine Sync value
CF_TDOTS_%1[CR]	Set Total Dots value
CF_CLAMP_%1[CR]	Set Clamp Value
CF_H-POS_%1[CR]	Set Horizontal Position value
CF_V-POS_%1[CR]	Set Vertical Position value
CF_DDOTS_%1[CR]	Set Display Dots value
CF_DLINE_%1[CR]	Set Display Line value
CF_PCSTORE_%1[CR]	Store the setting value in PC Adjust menu to Mode 1-5
CF_PCMODEFREE_%1[CR]	Delete the registered value in Mode1-5 and return it to Free status

5.3 Input Control Command Table

Execute command	Item
CF_INPUT_%1[CR]	Select Input
CF_SOURCE_%1[CR]	Select Input Source
CF_INPUT_%1_%2[CR]	Select Input and Source
CF_SYSTEM_%1[CR]	Select System

5.4 Screen Command Table

Execute command	Item
CF_SCREEN_%1[CR]	Select Screen size
CF_DZCENT_%1[CR]	Cancel Digital Zoom mode
CF_KEYSTONE_%1[CR]	Set Keystone
CF_KYSTNMODE_%1[CR]	Set Keystone Store mode

5.5 Lamp Command Table

Execute command	Item
CF_LAMPH_%1[CR]	Reset total running time for each lamp
CF_LAMPMODE_%1[CR]	Select Lamp mode

5.6 Sound Command Table

Execute command	Item
CF_VOLUME_%1[CR]	Set Volume value
CF_MUTE_%1[CR]	Control ON/OFF of Sound Mute

5.7 Setting Command Table

Execute command	Item
CF_BBACK_%1[CR]	Set Blue Back function
CF_DISP_%1[CR]	Set Display function
CF_LOGO_%1[CR]	Set Logo function
CF_CEIL_%1[CR]	Set Ceiling function
CF_REAR_%1[CR]	Set Rear function
CF_RCODE_%1[CR]	Select Remote Control Reception Code
CF_LANG_%1[CR]	Select language for OSD
CF_ZOOM_%1[CR]	Select Zoom store mode
CF_INPUTSEARCH_%1[CR]	Set Input search function
CF_ON-STA_%1[CR]	Set Power ON Start function
CF_P-MANE_%1[CR]	Set Power management function
CF_P-MANETIME_%1[CR]	Set Power management time
CF_FANSPEED_%1[CR]	Select Fan Speed
CF_KEYDIS_%1[CR]	Prohibit RC/KEY
CF_TERMINAL_%1[CR]	Set Terminal terminal
CF_FDEFAULT_%1[CR]	Set the value to Factory Default
CF_LOGOCAPTURE_%1[CR]	Capture a projected image
CF_FANMODE_%1[CR]	Select Fan mode
CF_UNIFORMITY_%1[CR]	Set Uniformity function.
CF_FILH_%1[CR]	Set Timer for Filter cleaning/replacement Warning.
CF_FILTIMER_%1[CR]	Reset Filter use time.

6. Status Read Command Table

6.1 Image Status Read Command Table

Status read command	Item
CR_BRIGHT[CR]	Get Brightness value
CR_CONT[CR]	Get Contrast value
CR_COLOR[CR]	Get Color value
CR_TINT[CR]	Get Tint value
CR_SHARP[CR]	Get Sharpness value
CR_GAMMA[CR]	Get Gamma value
CR_WBAL-R[CR]	White Balance Red value
CR_WBAL-G[CR]	White Balance Green value
CR_WBAL-B[CR]	White Balance Blue value
CR_COLTEMP[CR]	Get Color temperature setting value
CR_NZRED[CR]	Get Noise reduction setting status
CR_PROGV[CR]	Get Progressive scan setting status
CR_IMAGE[CR]	Get Selected Image status
CR_IMGGMD[CR]	Get Image Gamma setting value

6.2 PC Adjust Status Read Command Table

Status read command	Item
CR_FSYNC[CR]	Get Fine Sync setting value
CR_TDOTS[CR]	Get Total Dots setting value
CR_CLAMP[CR]	Get Clamp setting value
CR_H-POS[CR]	Get Horizontal Position setting value
CR_V-POS[CR]	Get Vertical Position setting value
CR_DDOTS[CR]	Get Display Dots setting value
CR_DLINE[CR]	Get Display Line setting value
CR_PCSTORE[CR]	Get Free or Stored status for PC Adj. mode1-5
CR_SETPCADJ[CR]	Get current PC signal for PC display status

6.3 Video Status Read Command Table

Status read command	Item
CR_SERSYS[CR]	Get selected current signal. When in Auto mode, it returns a result by Auto detect.

6.4 Input Status Read Command Table

Status read command	Item
CR_INPUT[CR]	Get selected Input status
CR_SOURCE[CR]	Get selected source of currently selected Input
CR_INPUT_%1[CR]	Get status of selected input and selected source
CR_SYSTEM[CR]	Get selected system status in Input mode

6.5 Screen Status Read Command Table

Status read command	Item
CR_SCREEN[CR]	Get selected screen size
CR_FLSCREEN[CR]	Get Full Screen mode setting status
CR_TRUE[CR]	Get True mode setting status
CR_KYSTNMODE[CR]	Get Keystone Store mode setting status

6.6 Lamp Status Read Command Table

Status read command	Item
CR_LAMPREPL[CR]	Get the information for Lamp replacement time
CR_LAMPMODE[CR]	Get Lamp Mode status
CR_PROJH[CR]	Get projector total running time

6.7 Sound Status Read Command Table

Status read command	Item
CR_VOLUME[CR]	Get Volume value
CR_MUTE[CR]	Get Sound Mute setting status

6.8 Setting Status Read Command Table

Status read command	Item
CR_BBACK[CR]	Get Blue Back setting status
CR_DISP[CR]	Get Display setting status
CR_LOGO[CR]	Get Logo setting status
CR_CEIL[CR]	Get Ceilsetting status
CR_REAR[CR]	Get Rear setting status
CR_RCODE[CR]	Get selected Remote Control Code
CR_LANG[CR]	Get selected language
CR_ZOOM[CR]	Get status of Zoom store mode.
CR_INPUTSEARCH[CR]	Get Input search setting status
CR_ON-STA[CR]	Get ON Start setting status
CR_INPUTSEARCH[CR]	Get Input search setting status
CR_P-MANE[CR]	Get Power management setting status
CR_P-MANETIME[CR]	Get setting time for Power management
CR_FANSPEED[CR]	Get selected FAN CONTROL SPEED
CR_KEYDIS[CR]	Get RC/KEY prohibited status
CR_TERMINAL[CR]	Get Terminal setting status
CR_FANMODE[CR]	Get FAN mode setting status
CR_UNIFORMITY[CR]	Get Uuniformitysetting status
CR_FILH[CR]	Get Filter use time
CR_FILREPL[CR]	Get information about Filter replacement timing
CR_FILTERTIMER[CR]	Get setting time of Filter warning timer

6.9 Other Status Read Command

Status read command	Item
CR_SIGNAL[CR]	Get Signal Status if there is a signal or not
CR_VMUTE[CR]	Get No Show setting status
CR_FREEZE[CR]	Get Freeze setting status
CR_PTIMER[CR]	Get the operating status of Presentation Timer
CR_TEMPWARN[CR]	Get Temperature Status if it is close to abnormal temperature
CR_TEMPFAIL[C444R]	Get temperature when sensors approach abnormal temperature

7. Error Code Table

Error Code	Contents
?	-When the received data cannot be decoded -Parameter determination error (digit number error, including invalid value, etc.)
000	Normal reception (No error)
101	The function is not available in the selected Mode
102	Selected value is out of range (Not reflected)
103	Command mismatched to Hardware (command for Optional function which is not installed)
201	When reached upper or lower limit of increasing or decreasing data
301	Command cannot be executed during capturing display. Resend the command after a while
302	
303	
402	Command cannot be executed during PIN code operation. Resend the command after a while.

Note) These error codes are applied in Expand Command, not in Basic Command

8. Functional Execution Command

8.1 Format

1)PC issues commands in format as below:

Pattern1 : “CF **COMMAND**” [CR]

Pattern2 : “CF **COMMAND**_%1 [CR]

CF_ : Header

COMMAND : Character line

%1 : Parameter (Character line)

_ : Space (To separate COMMAND and Parameter)

2)The projector decodes the received command and when it is ready to receive the next command, it returns the response.

“000” [CR] : (0x06, 0x0D) When receiving Functional Execution Command

“nnn” [CR] : Except “000”, when it is unable to execute command by any specific reason.

See Error Code Table for details

3)When the received data cannot be decoded, the projector returns “?” [CR]

8.2 Transfer Example

When setting projector's total dots to 1344 by Expand Serial Command

PC → PJ: "CF_TDOTS_1344" [CR]

PC ← PJ: "000"[CR] - - - - - Acceptable

8.3 Operation Requirements

Functional Execution Command is limited when the projector status is as below.

However, Status Read Command is effective even under these conditions.

Projector Status	Available Functional Execution Command
Standby Mode	C00: POWER ON
Processing Countdown	C00: POWER ON (Terminates Countdown) C01: POWER OFF C02: POWER OFF (Terminates Countdown)
Processing Cooling down	N/A
Processing Cooling down due to Abnormal Temperature	N/A
Abnormal Temperature	N/A
Power Failure (For 60 seconds after Power Failure occurred)	N/A
Processing Power Save / Cooling down	N/A
Processing Power Save	C00: POWER ON C01: POWER OFF
Input search : On1/On2	Input search does not operate while receiving INPUT command nor related commands.

Note:) When the projector receives the other command in this above status, it returns error code to show the status.

When the projector receives the following functional execution commands, OSD menu is closed except for pop-up menu

8.4 Image Command

8.4.1 CF_BRIGHT Command

Command	"CF_BRIGHT_%1"[CR]	
%1	"000~063" ----- Directly select Brightness setting value "UP" ----- Current Brightness setting value + 1 "DN" ----- Current Brightness setting value - 1	
Details	Set Brightness value of user control The value set by this command will not be saved to the projector. Therefore, when ALL is OFF, the value returns to the original setting. (The value is held in Suspend mode.) This command is available in the normal Power ON status.	
Response	Acceptable	"000"[CR]
	Unacceptable	"Error Code"[CR]

8.4.2 CF_CONT Command

Command	"CF_CONT_%1"[CR]	
%1	"000~063" ----- Directly select Contrast setting value "UP" ----- Current Contrast setting value + 1 "DN" ----- Current Contrast setting value - 1	
Details	Set Contrast value of user control The value set by this command will not be saved to the projector. Therefore, when ALL is OFF, the value returns to the original setting. (The value is held in Suspend mode.) This command is available in the normal Power ON status.	
Response	Acceptable	"000"[CR]
	Unacceptable	"Error Code"[CR]

8.4.3 CF_COLOR Command

Command	"CF_COLOR_%1"[CR]	
%1	"000~063" ----- Directly select Color setting value "UP" ----- Current Color setting value + 1 "DN" ----- Current Color setting value - 1	
Details	Set Color value of user control The value set by this command will not be saved to the projector. Therefore, when ALL is OFF, the value returns to the original setting. (The value is held in Suspend mode) This command is available in the normal Power ON status.	
Response	Acceptable	"000"[CR]
	Unacceptable	"Error Code"[CR]

8.4.4 CF_TINT Command

Command	"CF_TINT_%1"[CR]	
%1	"000~063" ----- Directly select Tint setting value "UP" ----- Current Tint setting value + 1 "DN" ----- Current Tint setting value - 1	
Details	Set Tint value of user control The value set by this command will not be saved to the projector. Therefore, when ALL is OFF, the value returns to the original setting. (The value is held in Suspend mode) This command is available in the normal Power ON status.	
Response	Acceptable	"000"[CR]
	Unacceptable	"Error Code"[CR]

8.4.5 CF_SHARP Command

Command	"CF_SHARP_%1"[CR]	
%1	"000~015" ----- Directly select Sharpness setting value "UP" ----- Current Sharpness setting value + 1 "DN" ----- Current Sharpness setting value - 1	
Details	Set Sharpness value of user control The value set by this command will not be saved to the projector. Therefore, when ALL is OFF, the value returns to the original setting (The value is held in Suspend mode) This command is available in the normal Power ON status.	
Response	Acceptable	"000"[CR]
	Unacceptable	"Error Code"[CR]

8.4.6 CF_GAMMA Command

Command	"CF_GAMMA_%1"[CR]	
%1	"000~015" ----- Directly set Gamma setting value "UP" ----- Current Gamma setting value + 1 "DN" ----- Current Gamma setting value - 1	
Details	Set Gamma value of user control The value set by this command will not be saved to the projector. Therefore, when ALL is OFF, the value returns to the original setting (The value is held in Suspend mode) This command is available in the normal Power ON status.	
Response	Acceptable	"000"[CR]
	Unacceptable	"Error Code"[CR]

8.4.7 CF_WBAL - Command

Command	"CF_WBAL-%1_%2"[CR]	
%1	" R " ----- Red " G " ----- Green " B " ----- Blue	
%2	"000~063" ----- Directly select Color value set by White Balance%1 "UP" ----- Current Color value set by White Balance%1 + 1 "DN" ----- Current Color value set by White Balance%1 - 1	
Details	Set Color value set by White Balance%1 of user control The value set by this command will not be saved to the projector. Therefore, when ALL is OFF, the value returns to the original setting (The value is held in Suspend mode) This command is available in the normal Power ON status.	
Response	Acceptable	"000"[CR]
	Unacceptable	"Error Code"[CR]

8.4.8 CF_COLTEMP Command

Command	"CF_COLTEMP_%1"[CR]	
%1	"000" ----- Xlow "001" ----- Low "002" ----- Mid "003" ----- High	
Details	Set Color Temp. (Available only in the normal Power ON status) The value set by this command will not be saved to the projector. Therefore, when ALL is OFF, the value returns to the original setting (The value is held in Suspend mode) This command is available in the normal Power ON status.	
Response	Acceptable	"000"[CR]
	Unacceptable	"Error Code"[CR]

8.4.9 CF_PROGV Command

Command	"CF_PROGV_%1"[CR]	
%1	"FILM" ----- Select Progressive Mode FILM "L1" ----- Select Progressive Mode L1 "L2" ----- Select Progressive Mode L2 "OFF" ----- Cancel Progressive scan	
Details	Set / cancel Progressive scan (Available only in the normal Power ON status) The value set by this command will not be saved to the projector. Therefore, when ALL is OFF, the value returns to the original setting (The value is held in Suspend mode) This command is available in the normal Power ON status.	
Response	Acceptable	"000"[CR]
	Unacceptable	"Error Code"[CR]

8.4.10 CF_NZRED Command

Command	"CF_NZRED_%1"[CR]	
%1	"OFF" ----- Cancel Noise Reduction "L1" ----- Noise Reduction for moving image "L2" ----- Noise Reduction for still image	
Details	Set Noise Reduction of User control The value set by this command will not be saved to the projector. Therefore, when ALL is OFF, the value returns to the original setting (The value is held in Suspend mode) This command is available in the normal Power ON status.	
Response	Acceptable	"000"[CR]
	Unacceptable	"Error Code"[CR]

8.4.11 CF_IMAGE Command

Command	"CF_IMAGE_%1"[CR]	
%1	"DYNAMIC" ----- Dynamic (Fixed value to enable projection with a sharp, powerful picture tone) "STAND" ----- Standard (Image adjust value is set to factory default) "REAL" ----- Real (Fixed value to display graphic image with natural tone) "CINEMA" ----- Cinema (Fixed value to focus on tone reproduction for movie) "BLACKBOARD" – Blackboard (Fixed value to project image onto grren-colored blackboard) "COLORBOARD " – Colorboard(Fixed value to project image onto colored board) "CUSTOM1" ----- Image1 (the value set and stored by a user) "CUSTOM2" ----- Image2 (the value set and stored by a user) "CUSTOM3" ----- Image3 (the value set and stored by a user) "CUSTOM4" ----- Image4 (the value set and stored by a user)	
Details	Select Image Mode (Available only in the normal Power ON status) Parameter "CUSTOM1" to "CUSTOM4" is the same as "Image1" to "Image4" displayed when selecting Image on OSD menu. The value set by this command is stored in EEPROM and its setting is effective even after ALL is OFF.	
Response	Acceptable	"000"[CR]
	Unacceptable	"Error Code"[CR]

8.4.12 CF_IMAGEADJ Command

Command	"CF_IMAGEADJ_%1"[CR]	
%1	"RST" ----- Reset Image adjustment "STR1" ----- Store current Image adjustment to Image 1 "STR2" ----- Store current Image adjustment to Image 2 "STR3" ----- Store current Image adjustment to Image 3 "STR4" ----- Store current Image adjustment to Image 4	
Details	Reset / store Image adjustment. (Available only in the normal Power ON statement) Parameter "STR1" to "STR4" is the same as "Image1" to "Image4" displayed when adjusting Image on OSD menu and selecting "Store" The value stored to "Image1-4" is saved and its setting is effective even after ALL is OFF.	
Response	Acceptable	"000"[CR]
	Unacceptable	"Error Code"[CR]

8.5 PC Adjust Control Command

8.5.1 CF_FSYNC Command

Command	"CF_FSYNC_%1"[CR]	
%1	"0000~0031" ----- Directly select Fine Sync setting value "UP" ----- Current Fine Sync setting value + 1 "DN" ----- Current Fine Sync setting value - 1	
Details	Set Fine Sync value of PC signal (Available only in the normal Power ON status) The value set by this command will not be saved to the projector. Therefore, when ALL is OFF, the value returns to the original setting	
Response	Acceptable	"000"[CR]
	Unacceptable	"101"[CR] --- when Input for Video is selected or no signal is found

8.5.2 CF_TDOTS Command

Command	"CF_TDOTS_%1"[CR]	
%1	"nnnn~mmmm" --- Directly select Total Dots setting value "nnnn" shows minimum value, it is current Display Dots value + Horizontal Position value. "mmmm" shows maximum value, it depends on current input signal. "UP" ----- Current Total Dots setting value + 1 "DN" ----- Current Total Dots setting value - 1	
Details	Set Total Dots of PC signal (Available only in the normal Power ON status) The value set by this command will not be saved to the projector. Therefore, when ALL is OFF, the value returns to the original setting	
Response	Acceptable	"000"[CR]
	Unacceptable	"101"[CR] ---- when Input for Video is selected

8.5.3 CF_CLAMP Command

Command	"CF_CLAMP_%1"[CR]	
%1	" nnnn ~ mmmm " Specify Clamp setting value directly " nnnn " indicates minimum value and fixed to " 0001 " " mmmm " indicates maximum value and it changes depend on Input signal "UP" ----- Current Clamp setting value + 1 "DN" ----- Current Clamp setting value - 1	
Details	Set Clamp value of PC signal (Available only in the normal Power ON status) The value set by this command will not be saved to the projector. Therefore, when ALL is OFF, the value returns to the original setting	
Response	Acceptable	"000"[CR]
	Unacceptable	"101"[CR] ---- when Input for Video is selected or no signal is found

8.5.4 CF_H – POS Command

Command	"CF_H-POS_%1"[CR]	
%1	"0000~nnnn" --- Directly select Horizontal Position setting value "nnnn" shows maximum value, it is current Total Dots value - Display Dots value "UP" ----- Current Horizontal Position setting value + 1 "DN" ----- Current Horizontal Position setting value - 1	
Details	Set Horizontal Position value of PC signal. (Available only in the normal Power ON status) The value set by this command will not be saved to the projector. Therefore, when ALL is OFF, the value returns to the original setting	
Response	Acceptable	"000"[CR]
	Unacceptable	"101"[CR] ---- when Input for Video is selected or no signal is found

8.5.5 CF_V – POS Command

Command	"CF_V-POS_%1"[CR]	
%1	"0000~nnnn" --- Directly select Vertical Position setting value "nnnn" shows maximum value, it is current Total Line value - Display Line value "UP" ----- Current Vertical Position setting value + 1 "DN" ----- Current Vertical Position setting value - 1	
Details	Set Vertical Position value of PC signal (Available only in the normal Power ON status) The value set by this command will not be saved to the projector. Therefore, when ALL is OFF, the value returns to the original setting	
Response	Acceptable	"000"[CR]
	Unacceptable	"101"[CR] ---- When Input source is Video system or no signal is found

8.5.6 CF_DDOTS Command

Command	"CF_DDOTS_%1"[CR]	
%1	"0100~nnnn" --- Directly select Display Dots setting value "nnnn" shows maximum value, it is current Total Dots value - Horizontal Position value Even number is available and when odd number is set, it is rounded out. "UP" ----- Current Vertical Position setting value + 2 "DN" ----- Current Vertical Position setting value - 2	
Details	Set Display Dots value of PC signal The value set by this command will not be saved to the projector. Therefore, when ALL is OFF, the value returns to the original setting. This command is available in the normal Power ON status.	
Response	Acceptable	"000"[CR]
	Unacceptable	"101"[CR] ---- When Input for Video is selected or no signal is found

8.5.7 CF_DLINE Command

Command	"CF_DLINE_%1"[CR]	
%1	"0100~nnnn" --- Directly select Display Line setting value "nnnn" shows maximum value, it is current Total Line value – Vertical Position value "UP" ----- Current Display Line setting value + 1 "DN" ----- Current Display Line setting value – 1	
Details	Set Display Line value of PC signal (Available only in the normal Power ON status) The value set by this command will not be saved to the projector. Therefore, when ALL is OFF, the value returns to the original setting.	
Response	Acceptable	"000"[CR]
	Unacceptable	"101"[CR] ---- When Input for Video is selected or no signal is found

8.5.8 CF_PCSTORE Command

Command	"CF_PCSTORE_%1"[CR]	
%1	"MODE1" ---- Store current PC Adjust status to Mode1 "MODE2" ---- Store current PC Adjust status to Mode2 "MODE3" ---- Store current PC Adjust status to Mode3 "MODE4" ---- Store current PC Adjust status to Mode4 "MODE5" ---- Store current PC Adjust status to Mode5	
Details	Store current PC Adjust status (each parameter status such as Total dots) to Mode1~Mode5. This command operates the same as storing to Mode1-Mode5 in PC Adjust MENU. (Available only in the normal Power ON status)	
Response	Acceptable	"000"[CR]
	Unacceptable	"101"[CR] ---- When Input for Video is selected or no signal is found

8.5.9 CF_PCMODEFREE Command

Command	"CF_PCMODEFREE_%1"[CR]	
%1	"MODE1" ---- Free Mode1 "MODE2" ---- Free Mode2 "MODE3" ---- Free Mode3 "MODE4" ---- Free Mode4 "MODE5" ---- Free Mode5	
Details	Delete the registered data in Mode1-Mode5 and turns it to Free status. This command operates the same as turning Mode1-Mode5 to Free in PC Adjust Menu. (Available only in the normal Power ON status)	
Response	Acceptable	"000"[CR]
	Unacceptable	"101"[CR] ---- When Input for Video is selected or no signal is found.

8.6 Input Control Command

8.6.1 CF_INPUT Command (Network mode is not available)

Command	"CF_INPUT_%1"[CR]	
%1	"COMPUTER1" ----- Select Computer 1 Input "COMPUTER2" ----- Select Computer 2 Input "VIDEO" ----- Select Video Input	
Details	Select Input (Available only in the normal Power ON status) The same operation as "INPUT" button of Remote Control. Note) When Input 2(Computer 2) is set to Monitor Out by Terminal setting, Projector returns "101" by selecting Input 2.	
Response	Acceptable	"000"[CR]
	Unacceptable	"Error Code"[CR]

8.6.2 CF_SOURCE Command

Command	"CF_SOURCE_%1"[CR]	
%1	Input is 1	"ANALOG" ----- Select Analog Input "YPBPR" ----- Select Component "SCART" ----- Select Scart Input
	Input is 2	"ANALOG" ----- Select RGB
	Input is 3	"AUTO" ----- Select Vide Auto mode "VIDEO" ----- Select Composite Video Input "S - VIDEO" ----- Select S-Video Input "YPBPR" ----- Select Component Input
Details	Select Source of currently selected Input (Available only in the normal Power ON status) When Input specified by %1 is inappropriate for selected Input, the projector returns "101" and this command is not executed. When Input search is On1/On2, this command is not executed while the projector returns OK.	
Response	Acceptable	"000"[CR]
	Unacceptable	"Error Code"[CR]

8.6.3 CF_INPUT_%1_%2 Command

Command	"CF_INPUT_%1_%2"[CR]	
%1	"COMPUTER1" ---- Select Computer 1 Input "COMPUTER2" ---- Select Computer 2 Input "VIDEO" ----- Select Analog Input	
%2	When %1 is COMPUTER1 "ANALOG" ---- Select Analog RGB Input "YPBPR" ----- Select Component Input "SCART" ----- Select SCART Input When %1 is COMPUTER2 "ANALOG" ---- Select Analog RGB Input When %1 is VIDEO "AUTO" ----- Select Video Auto Mode "VIDEO" ----- Select Video Input "S-VIDEO" ----- Select S-Video Input "YPBPR" ----- Select Component Input	
Details	Select Input specified by %1 and also Source specified by %2 (Available only in the normal Power ON status) Note1) When Input 2(Computer 2) is set to Monitor Out by Terminal setting, Projector returns "101" by selecting Input 2. Note2) When Input search is On1/On2, this command is not executed while the projector returns OK.	
Response	Acceptable	"000"[CR]

	Unacceptable	"Error Code"[CR]
--	--------------	------------------

8.6.4 CF_SYSTEM Command

Command	"CF_SYSTEM_%1"[CR]	
%1	Input is Computer	"MODE1" ----- Select Mode 1 "MODE2" ----- Select Mode 2 "MODE3" ----- Select Mode 3 "MODE4" ----- Select Mode 4 "MODE5" ----- Select Mode 5
	Input is Video	"AUTO" ----- Select System "Auto" "NTSC" ----- Select NTSC "NTSC443" ----- Select NTSC4.43 "PAL" ----- Select PAL "SECAM" ----- Select SECAM "PAL-M" ----- Select PAL-M "PAL-N" ----- Select PAL-N "1080I" ----- Select 1080i "1035I" ----- Select 1035i "720P" ----- Select 720p "575P" ----- Select 575p "480P" ----- Select 480p "575I" ----- Select 575i "480I" ----- Select 480i
Details	Select System of currently selected Input (Available only in the normal Power ON status) When Input specified by %1 is inappropriate for selected Input, the projector returns "101"[CR] and the command is not executed Note1) "NTSC" / "NTSC4.43" / "PAL" / "SECAM" / "PAL-M" / "PAL-N" is available only when Input is VIDEO / S-VIDEO Note2) "1080I" / "1035I" / "720p" / "575P" / "480P" / "575I" / "480I" is available only when Input is Y / Pb/Cb / Pr/Cr	
Response	Acceptable	"000"[CR]
	Unacceptable	"Error Code"[CR]

8.7 Screen Control Command

8.7.1 CF_SCREEN Command

Command	"CF_SCREEN_%1"[CR]	
%1	Input is Computer	"NORMAL" ----- Select Normal "WIDE" ----- Select Wide "TRUE" ----- Select True size "FULL" ----- Select Full size "DZOOM_UP" ----- Expand image size with Digital Zoom "DZOOM_DN" ----- Compress image size with Digital Zoom
	Input is Video	"NORMAL" ----- Select Normal "WIDE" ----- Select Wide
Details	Select screen size (Available only in the normal Power ON status) When Input specified by %1 is inappropriate for selected Input, the projector returns "101"[CR] and the command is not executed	
Response	Acceptable	"000"[CR]
	Unacceptable	"Error Code"[CR] "201"[CR] --- When reaches the correction limit

8.7.2 CF_DZCENT Command

Command	"CF_DZCENT_%1"[CR]	
%1	"CENT" ---- Cancel Digital Zoom (CENT : "CENTER")	
Details	Cancel Digital Zoom When image is expanded / reduced, this command reset its value to "0" (Available only in the normal Power ON status and Input for Computer is selected)	
Response	Acceptable	"000"[CR]
	Unacceptable	"101"[CR] ----- when Input for Video is selected

8.7.3 CF_KEYSTONE Command

Command	"CF_KEYSTONE_%1"[CR]	
%1	"UP" ----- Correct Keystone distortion to reduce upper part of image "FUP" ----- Correct Keystone distortion to reduce upper part by 2 steps "DN" ----- Correct Keystone distortion to reduce lower part of image "FDN" ----- Correct Keystone distortion to reduce lower part by 2 steps "RST" ----- Set Keystone OFF	
Details	Change Keystone distortion correction (Available only in the normal Power ON status)	
Response	Acceptable	"000"[CR]
	Unacceptable	"Error Code"[CR] "201"[CR] ----When reaches the Keystone correction limit or when reaches correction limit by 1 step with "FDN"/"FUP" (command is not executed)

8.7.4 CF_KYSTNMODE Command

Command	"CF_KYSTNMODE_%1"[CR]	
%1	"STR" ----- Set Keystone store mode to Store "RST" ----- Set Keystone store mode to Reset	
Details	Set Keystone store mode (Available only in the normal Power ON status)	
Response	Acceptable	"000"[CR]
	Unacceptable	"Error Code"[CR]

8.8 Lamp Command

8.8.1 CF_LAMPH Command

Command	"CF_LAMPH_%1"[CR]	
%1	"RST"	
Details	Reset lamp total running time (Available only in the normal Power ON status)	
Response	Acceptable	"000"[CR]
	Unacceptable	"Error Code"[CR]

8.8.2 CF_LAMPMODE Command

Command	"CF_LAMPMODE_%1"[CR]	
%1	"NORMAL" ----- Set lamp to Normal mode status "ECO" ----- Set lamp to Eco mode status "AUTO" ----- Set lamp to Auto mode status	
Details	Select Lamp Mode (Available only in the normal Power ON status) The value set by this command is stored in EEPROM and its setting is effective even after ALL is OFF.	
Response	Acceptable	"000"[CR]
	Unacceptable	"Error Code"[CR]

8.9 Sound Command

8.9.1 CF_VOLUME Command

Command	"CF_VOLUME_%1"[CR]	
%1	"000-063" ----- Directly select Volume setting value "UP" ----- Current Volume setting value +1 "DN" ----- Current Volume setting value -1	
Details	Set Volume value (Available only in the normal Power ON status) The same operation as Volume Up/Down with RC Key, and directly select Volume setting value. When setting Volume value, the Sound Mute ON status is canceled just like RC operation. The value set by this command is stored in Projector.	
Response	Acceptable	"000"[CR]
	Unacceptable	"Error Code"[CR]

8.9.2 CF_MUTE Command

Command	"CF_MUTE_%1"[CR]	
%1	"ON" ----- Set Sound Mute ON "OFF" ----- Set Sound Mute OFF	
Details	Set Sound Mute ON/OFF (Available only in the normal Power ON status)	
Response	Acceptable	"000"[CR]
	Unacceptable	"Error Code"[CR]

8.10 Setting Command

8.10.1 CF_BBACK Command

Command	"CF_BBACK_%1"[CR]	
%1	"ON" ----- Select Blue Back "OFF" ----- Cancel Blue Back	
Details	Set / Cancel Blue Back (Available only in the normal Power ON status) The value set by this command is stored in EEPROM and its setting is effective even after ALL is OFF.	
Response	Acceptable	"000"[CR]
	Unacceptable	"Error Code"[CR]

8.10.2 CF_DISP Command

Command	"CF_DISP_%1"[CR]	
%1	"ON" ----- Select Display "OFF" ----- Cancel Display "CNTDWNOFF" ----- Count down OFF	
Details	Set / Cancel Display (Available only in the normal Power ON status) The value set by this command is stored in EEPROM and its setting is effective even after ALL is OFF.	
Response	Acceptable	"000"[CR]
	Unacceptable	"Error Code"[CR]

8.10.3 CF_LOGO Command

Command	"CF_LOGO_%1"[CR]	
%1	"OFF" ----- Cancel Logo display "DEFAULT" ----- Set Default Logo display "USER" ----- Set Captured Logo display	
Details	Set / Cancel Logo (Available only in the normal Power ON status) The value set by this command is stored in EEPROM and its setting is effective even after ALL is OFF In case capture is not yet excuted, Projector returns error code "101" by receiving "User"	
Response	Acceptable	"000"[CR]
	Unacceptable	"Error Code"[CR] "101" ----- When Logo is locked by Logo PIN code

8.10.4 CF_CEIL Command

Command	"CF_CEIL_%1"[CR]	
%1	"ON" ----- Select Ceiling "OFF" ----- Cancel Ceiling	
Details	Set / Cancel Ceiling (Available only in the normal Power ON status) The value set by this command is stored in EEPROM and its setting is effective even after ALL is OFF	
Response	Acceptable	"000"[CR]
	Unacceptable	"Error Code"[CR]

8.10.5 CF_REAR Command

Command	"CF_REAR_%1"[CR]	
%1	"ON" ----- Select Rear "OFF" ----- Cancel Rear	
Details	Set/Cancel Rear (Available only in the normal Power ON status) When Rear is ON, image is left/right reversed. The status set by this command is stored in EEPROM and its setting is effective after ALL is OFF	
Response	Acceptable	"000"[CR]
	Unacceptable	"Error Code"[CR]

8.10.6 CF_RCODE Command

Command	"CF_RCODE_%1"[CR]	
%1	"001" ----- Select Code1 "002" ----- Select Code2	
Details	Select Code of Remote Control (Available only in the normal Power ON status) The status set by this command is stored in EEPROM and its setting is effective after ALL is OFF	
Response	Acceptable	"000"[CR]
	Unacceptable	"Error Code"[CR]

8.10.7 CF_LANG Command

Command	"CF_LANG_%1"[CR]	
%1	"ENG" ----- Select ENGLISH "DEU" ----- Select German "FRA" ----- Select French "ITA" ----- Select Italian "ESP" ----- Select Spanish "POR" ----- Select Portuguese "NED" ----- Select Dutch "SVE" ----- Select Swedish "RUS" ----- Select Russian "CHI" ----- Select Chinese "KOR" ----- Select Korean "JPN" ----- Select Japanese "FIN" ----- Select Finnish "POL" ----- Select Polish "HUN" ----- Select Hungarian "ROM" ----- Select Romanian	
Details	Set language for OSD (Available only in the normal Power ON status) The language set by this command is stored in EEPROM and its setting is effective after ALL is OFF.	
Response	Acceptable	"000"[CR]
	Unacceptable	"Error Code"[CR]

8.10.8 CF_ZOOM Command

Command	"CF_ZOOM_%1"[CR]	
%1	"RST"..... Set Zoom store mode to "Reset" "STR1"..... Set Zoom store mode to Store1 "STR2"..... Set Zoom store mode to Store2	
Details	Slect settinf status of Zoom store mode. (Available only in the normal Power ON status). The status set by this command is stored in EEPROM and its setting is effective after ALL is OFF.	
Response	Acceptable	"000"[CR]
	Unacceptable	"Error Code"[CR]

8.10.9 CF_INPUTSEARCH Command

Command	"CF_INPUTSEARCH_%1"[CR]	
%1	"OFF"..... Input search OFF "ON1"..... Set Input search On1 "ON 2"..... Set Input search On2	
Details	Set Input search mode (Available only in the normal Power ON status). The status set by this command is stored in EEPROM and its setting is effective after ALL is OFF.	
Response	Acceptable	"000"[CR]
	Unacceptable	"Error Code"[CR]

8.10.10 CF_ON – STA Command

Command	"CF_ON - STA_%1"[CR]	
%1	"ON" ----- Select Power On Start "OFF" ----- Cancel Power On Start	
Details	Set/Cancel Power ON Start (Available only in the normal Power ON status) The status set by this command is stored in EEPROM and its setting is effective after ALL is OFF	
Response	Acceptable	"000"[CR]
	Unacceptable	"Error Code"[CR]

8.10.11 CF_P – MANE Command

Command	"CF_P - MANE_%1"[CR]	
%1	"OFF" ----- Set Power Management OFF "READY" ----- Set Power Management Ready "SHUTDOWN" ----- Set Power Management to Shut Down mode	
Details	Set/Cancel Power Management (Available only in the normal Power ON status) The status set by this command is stored in EEPROM and its setting is effective after ALL is OFF	
Response	Acceptable	"000"[CR]
	Unacceptable	"Error Code"[CR]

8.10.12 CF_P – MANETIME Command

Command	"CF_P-MANETIME_%1"[CR]	
% 1	"01" - "30" ----- Directly select setting time by the minute "UP" ----- Plus one minute "DN" ----- Minus one minute	
Details	Set Power Management time (Available only in the normal Power ON status) The status set by this command is stored in EEPROM and its setting is effective after ALL is OFF	
Response	Acceptable	"000"[CR]
	Unacceptable	"Error Code"[CR]

8.10.13 CF_FANSPEED Command

Command	"CF_FANSPEED_%1"[CR]	
% 1	"MAX" ----- Select maximum fan speed "NOR" ----- Select normal fan speed	
Details	Switch Fan Control Speed (Available only in the normal Power ON status) The status set by this command is stored in EEPROM and its setting is effective after ALL is OFF.	
Response	Acceptable	"000"[CR]
	Unacceptable	"Error Code"[CR]

8.10.14 CF_KEYDIS Command

Command	"CF_KEYDIS_%1"[CR]	
%1	"NONE" ----- RC & KEY are valid (All are valid) "RC" ----- RC is invalid "KEY" ----- KEY is invalid	
Details	Set a ban on the use of RC/KEY (Available only in the normal Power ON status)	
Response	Acceptable	"000"[CR]
	Unacceptable	"Error Code"[CR]

8.10.15 CF_TERMINAL Command

Command	"CF_TERMINAL_%1"[CR]	
%1	"COMPUTER" ----- Select "Computer " for Terminal setting "MONITOR" ----- Select "Monitor Out" for Terminal setting	
Details	Set Terminal (Available only in the normal Power ON status) Terminal for Computer input is Computer 2 in this model.	
Response	Acceptable	"000"[CR]
	Unacceptable	"Error Code"[CR] When Input is Computer 2, the projector returns "101" and the command is not executed

8.10.16 CF_FDEFAULT Command

Command	"CF_FDEFAULT_%1"[CR]	
%1	"RST"	
Details	Set the value to Factory Default (Available only in the normal Power ON status) The same operation as Factory Default of user menu.	
Response	Acceptable	"000"[CR]
	Unacceptable	"Error Code"[CR]

8.10.17 CF_LOGOCAPTURE Command

Command	"CF_LOGOCAPTURE_%1"[CR]	
%1	"START" ----- Capture ON	
Details	Capture projected image on screen. Once Projector starts capturing image, other command cannot be executed until "Capture" finishes. When the command is sent during this time, the projector returns error code "301"	
Response	Acceptable	"000"[CR]
	Unacceptable	"Error Code"[CR] "101" ---- When Logo is locked by Logo PIN code

8.10.18 CF_FANMODE Command

Command	"CF_FANMODE_%1"[CR]	
%1	"L1" ----- Select Fan Mode L1 "L2" ----- Select Fan Mode L2	
Details	Switch Fan Mode (Available only in the normal Power ON status) When L1 is selected, fan noise after POWER OFF is louder. When L2 is selected, fan noise after POWER OFF is more silent, however, fan rotates for a longer time than L1. The status set by this command is stored in EEPROM and its setting is effective even after ALL is OFF.	
Response	Acceptable	"000"[CR]
	Unacceptable	"Error Code"[CR]

8.10.19 CF_UNIFORMITY Command

Command	"CF_UNIFORMITY_%1"[CR]	
%1	"RESET" -----Set Uniformity store mode to "RESET" "STORE1" -----Set Uniformity store mode to "Store1" "STORE2" -----Set Uniformity store mode to "Store2"	
Details	Switch Uniformity store mode (Available only in the normal Power ON status) The status set by this command is stored in EEPROM and its setting is effective even after ALL is OFF.	
Response	Acceptable	"000"[CR]
	Unacceptable	"Error Code"[CR]

8.10.20 CF_FILTERTIMER Command

Command	"CF_FILTERTIMER_%1"[CR]	
%1	"100" ----- Set Timer on "100H" "200" ----- Set Timer on "200H" "300" ----- Set Timer on "300H" "OFF" ----- Set Timer "OFF"(No Warning is displayed)	
Details	Set timer of Filter warning display.	
Response	Acceptable	"000"[CR]
	Unacceptable	"Error Code"[CR]

8.10.21 CF_FANMODE Command

Command	"CF_FILH_%1"[CR]	
%1	"RST" ----- Reset Filter use time	
Details	Reset Projector Filter use time	
Response	Acceptable	"000"[CR]
	Unacceptable	"Error Code"[CR]

9. Status Read Command

9.1 Format

- 1) PC issues commands in format as below:

“CR_Command” [CR]

Command : Character Line

- 2) When projector receives the appropriate command, it returns a character line as the required data

“000_”%1 [CR]

%1: Required Data (Character Line. See [Basic Status Read Command Table])

- 3) When the received data cannot be decoded, the projector returns “?”[CR]

9.2 Transfer Example

Get total dots of projector by Expand Commands

PC → PJ: “CR_TDOTS” [CR]

PC ← PJ: “000_1344” [CR]

9.3 Operation Condition

Basically Status Read Commands should be always operated.

9.4 Image Status Read Command

9.4.1 CR_BRIGHT Command

Command	"CR_BRIGHT"[CR]	
Details	Get Brightness value of user control	
Response	Acceptable	"000_ % a "[CR]
	%a	"000"~"063"
	Unacceptable	"?"[CR]

9.4.2 CR_CONT Command

Command	"CR_CONT"[CR]	
Details	Get Contrast value of user control	
Response	Acceptable	"000_ % a "[CR]
	%a	"000"~"063"
	Unacceptable	"?"[CR]

9.4.3 CR_COLOR Command

Command	"CR_COLOR"[CR]	
Details	Get Color value of user control	
Response	Acceptable	"000_ % a "[CR]
	%a	"000"~"063"
	Unacceptable	"Error Code"[CR] ----- When the command is invalid due to condition such as Input source "?"[CR] ----- When unclear command is received

9.4.4 CR_TINT Command

Command	"CR_TINT"[CR]	
Details	Get Tint value of user control	
Response	Acceptable	"000_ % a "[CR]
	%a	"000"~"063"
	Unacceptable	"Error Code"[CR] ----- When the command is invalid due to condition such as Input source "?"[CR] ----- When unclear command is received

9.4.5 CR_SHARP Command

Command	"CR_SHARP"[CR]	
Details	Get Sharpness value of user control	
Response	Acceptable	"000_ % a "[CR]
	%a	"000"~"015"
	Unacceptable	"?"[CR]

9.4.6 CR_GAMMA Command

Command	"CR_GAMMA"[CR]	
Details	Get Gamma value of user control	
Response	Acceptable	"000_%a"[CR]
	%a	"000"~"015"
	Unacceptable	"?"[CR]

9.4.7 CR_WBAL – R Command

Command	"CR_WBAL-R"[CR]	
Details	Get White Balance Red value of user control	
Response	Acceptable	"000_%a"[CR]
	%a	"000"~"063"
	Unacceptable	"?"[CR]

9.4.8 CR_WBAL – G Command

Command	"CR_WBAL-G"[CR]	
Details	Get White Balance Green value of user control	
Response	Acceptable	"000_%a"[CR]
	%a	"000"~"063"
	Unacceptable	"?"[CR]

9.4.9 CR_WBAL – B Command

Command	"CR_WBAL-B"[CR]	
Details	Get White Balance Blue value of user control	
Response	Acceptable	"000_%a"[CR]
	%a	"000"~"063"
	Unacceptable	"?"[CR]

9.4.10 CR_COLTEMP Command

Command	"CR_COLTEMP"[CR]	
Details	Get Color Temp. setting value	
Response	Acceptable	"000_%a"[CR]
	%a	"000" ----- Xlow "001" ----- Low "002" ----- Mid "003" ----- High "ADJ" ----- Processing adjusting White Balance
	Unacceptable	"?"[CR]

9.4.11 CR_NZRED Command

Command	"CR_NZRED"[CR]	
Details	Get Noise Reduction setting status	
Response	Acceptable	"000_%1"[CR]
	%1	"L1" ----- Set Noise Reduction for moving image "L2" ----- Set Noise Reduction for still image "OFF" ----- Cancel Noise Reduction
	Unacceptable	"?"[CR]

9.4.12 CR_PROGV Command

Command	"CR_PROGV"[CR]	
Details	Get Progressive scan setting value	
Response	Acceptable	"000_%a"[CR]
	%a	"L1" ----- Set Progressive Mode L1 "L2" ----- Set Progressive Mode L2 "FILM" ----- Set Progressive Model FILM "OFF" ----- Cancel Progressive scan
	Unacceptable	"Error Code"[CR] ----- When the command is invalid due to condition such as Input source "?"[CR] ----- When unclear command is received

9.4.13 CR_IMAGE Command

Command	"CR_IMAGE"[CR]	
Details	Get image setting status Required data "CUSTOM1" to "CUSTOM4" is the same as "Image1" to "Image4" displayed when selecting IMAGE on OSD menu	
Response	Acceptable	"000_%a"[CR]
	%a	"DYNAMIC" ----- Dynamic "STAND" ----- Standard "REAL" ----- Real "CINEMA" ----- Cinema "BLACKBOARD" ----- Blackboard "COLORBOARD" ----- Colorboard "CUSTOM1"~"CUSTOM4" ----- Image1~4
	Unacceptable	"Error Code"[CR] ----- When the command is invalid due to condition such as Input source "?"[CR] ----- When unclear command is received

9.4.14 CR_IMGGMD Command

Command	"CR_IMGGMD"[CR]	
Details	Get Dynamic./Standard/Real/Cinema/Blackboard/Colorboard of Image Gamma setting status	
Response	Acceptable	"000_%a"[CR]
	%a	"DYN" ----- Dynamic "STD" ----- Standard "REL" ----- Real "CNM" ----- Cinema "BKB" ----- Blackboard "CLB" ----- Colorboard
	Unacceptable	"?"[CR]

9.5 PC Adjust Status Read Command

9.5.1 CR_FSYNC Command

Command	"CR_FSYNC"[CR]	
Details	Get Fine Sync value	
Response	Acceptable	"000_%a"[CR]
	%a	"0000"~"0031"
	Unacceptable	"Error Code"[CR] ----- When the command is invalid due to condition such as Input source "?"[CR] ----- When unclear command is received

9.5.2 CR_TDOTS Command

Command	"CR_TDOTS"[CR]	
Details	Get Total Dots value	
Response	Acceptable	"000_%a"[CR]
	%a	"nnnn"~"mmmm" (nnnn = Display Dots + Horizontal Position) (mmmm= Maximum value depends on input signal)
	Unacceptable	"Error Code"[CR] ----- When the command is invalid due to condition such as Input source "?"[CR] ----- When unclear command is received

9.5.3 CR_CLAMP Command

Command	"CR_CLAMP"[CR]	
Details	Get Clamp value	
Response	Acceptable	"000_%a"[CR]
	%a	"0001"~"nnnn" (nnnn=Total Dots – Display area H)
	Unacceptable	"Error Code"[CR] ----- When the command is invalid due to condition such as Input source "?"[CR] ----- When unclear command is received

9.5.4 CR_H – POS Command

Command	"CR_H - POS"[CR]	
Details	Get Horizontal Position value	
Response	Acceptable	"000_%a"[CR]
	%a	"0000"~"nnnn" (nnnn = Total Dots - Display Dots)
	Unacceptable	"Error Code"[CR] ----- When the command is invalid due to condition such as Input source "?"[CR] ----- When unclear command is received

9.5.5 CR_V – POS Command

Command	"CR_V - POS"[CR]	
Details	Get Vertical Position value	
Response	Acceptable	"000_%a"[CR]
	%a	"0000"~"nnnn" (nnnn = Total Line - Display Line)
	Unacceptable	"Error Code"[CR] ----- When the command is invalid due to condition such as Input source "?"[CR] ----- When unclear command is received

9.5.6 CR_DDOTS Command

Command	"CR_DDOTS"[CR]	
Details	Get Display Dots value	
Response	Acceptable	"000_%a"[CR]
	%a	"0100"~"nnnn" (nnnn = Total Dots – Horizontal Position value)
	Unacceptable	"Error Code"[CR] ----- When the command is invalid due to condition such as Input source "?"[CR] ----- When unclear command is received

9.5.7 CR_DLINE Command

Command	"CR_DLINE"[CR]	
Details	Get Display Line value	
Response	Acceptable	"000_%a"[CR]
	%a	"0100"~"nnnn" (nnnn = Total Line – Vertical Position value)
	Unacceptable	"Error Code"[CR] ----- When the command is invalid due to condition such as Input source "?"[CR] ----- When unclear command is received

9.5.8 CR_PCSTORE Command

Command	"CR_PCSTORE"[CR]	
Details	Get if MODE1 - MODE5 for PC Adjust are Free or Stored. Each data consists of 5 bytes and each byte represents MODE1~MODE5 respectively. (F:Free S:Stored)	
Response	Acceptable	"000_%a"[CR]
	Required Data	"FFFF" ----- All Free "SFFF" ----- MODE1 is Stored, others are Free : "FFFSS" ----- MODE5 is Stored, others are Free "SSSS" ----- All Stored
	Unacceptable	"Error Code"[CR] ----- When the command is invalid due to condition such as Input source "?"[CR] ----- When unclear command is received

9.5.9 CR_SETPCADJ Command

Command	"CR_SETPCADJ"[CR]	
Details	Get PC signal for current system	
Response	Acceptable	"000_%1"[CR]
	%1	"XGA1" "1080I60", "720P" "MODE1"~"MODE5" ...Etc.
	Unacceptable	"?"[CR]

9.6 Video Status Read Command

9.6.1 CR_SERSYS Command

Command	"CR_SERSYS"[CR]	
Details	Get current selected signal Returns auto-detect result in Auto mode Only available when Input is video (N/A when Input is computer)	
Response	Acceptable	"000_%a"[CR]
	%a	"1080I60" ----- 1080i 60Hz "1080I50" ----- 1080i 50Hz "1035I" ----- 1035i "720P" ----- 720p "575P" ----- 575p "480P" ----- 480p "575I" ----- 575i (includes Composite signal such as PAL) "480I" ----- 480i (includes Composite signal such as NTSC) "NO_SIGNAL" ----- There is no signal
	Unacceptable	"101"[CR] ----- When Input for PC is selected "?"[CR]

9.7 Input Status Read Command

9.7.1 CR_INPUT Command

Command	"CR_INPUT"[CR]	
Details	Get selected INPUT No.	
Response	Acceptable	"000_%a"[CR]
	%a	"COMPUTER1" ----- Computer1 Input is selected "COMPUTER2" ----- Computer2 Input is selected "VIDEO" ----- Video Input is selected
	Unacceptable	"?"[CR]

9.7.2 CR_SOURCE Command

Command	"CR_SOURCE"[CR]	
Details	Get selected Source	
Response	Acceptable	"000_%1"[CR]
	%1	"ANALOG" ----- Analog (RGB) Input is selected "SCART" ----- SCART is selected "AUTO" ----- Video Auto is selected "VIDEO" ----- Video Input is selected "S-VIDEO" ----- S-Video Input is selected "YCBCR" ----- Y,Pb/Cb,Pr/Cr Input is selected
	Unacceptable	"Error Code"[CR] ----- When the command is invalid due to condition such as Input source "?"[CR] ----- When unclear command is received

9.7.3 CR_INPUT_%1 Command

Command	"CR_INPUT_%1"[CR]	
%1	"COMPUTER1" ----- Select Computer 1 Input "COMPUTER2" ----- Select Computer 2 Input "VIDEO" ----- Select Video Input	
Details	Get selected source of currently selected Input	
Response	Acceptable	"000_%a"[CR]
	%a	When %1 is COMPUTER1 "ANALOG" ----- Analog RGB is selected "YPBPR" ----- Component Mode status "SCART" ----- Scart Mode status When %1 is COMPUTER2 "ANALOG" ----- Analog RGB Mode status "OUT" ----- Monitor OUT Mode status When %1 is VIDEO "AUTO" ----- Video Auto is selected "VIDEO" ----- Composite Video Input is selected "S-VIDEO" ----- S-Video Input is selected "YPBPR" ----- Component mode is selected
	Unacceptable	"?"[CR]

9.7.4 CR_SYSTEM Command

Command	"CR_SYSTEM"[CR]		
Details	Get selected System		
Response	Acceptable	"000_%1"[CR]	
	%1	Input is PC	Returns "101"
		Input is Video	"AUTO" ----- Auto is selected "NTSC" ----- NTSC is selected "NTSC443" ----- NTSC4.43 is selected "PAL" ----- PAL is selected "SECAM" ----- SECAM is selected "PAL-M" ----- PAL-M is selected "PAL-N" ----- PAL-N is selected "1080I" ----- 1080iHz is selected "1035I" ----- 1035iHz is selected "720P" ----- 720p is selected "575P" ----- 575p is selected "480P" ----- 480p is selected "575I" ----- 575i is selected "480I" ----- 480i is selected
	Unacceptable	"101"[CR] ----- When Input for PC is selected "?"[CR] ----- When unclear command is received	

9.8 Screen Status Read Command

9.8.1 CR_SCREEN Command

Command	"CR_SCREEN"[CR]	
Details	Get selected screen image size	
Response	Acceptable	"000_%a"[CR]
	%a	Input is PC "NORMAL" ----- Normal size screen mode "WIDE" ----- Wide size screen mode "TRUE" ----- True size screen mode "FULL" ----- Full screen mode When the screen is set to D.Zoom, returns the previous status (NORMAL/WIDE)
		Input is Video "NORMAL" ----- Normal size screen mode "WIDE" ----- Wide size screen mode
	Unacceptable	"Error Code"[CR] ----- When the command is invalid due to condition such as Input source "?"[CR]

9.8.2 CR_FLSCREEN Command

Command	"CR_FLSCREEN"[CR]	
Details	Get if screen size is set to Full Screen	
Response	Acceptable	"000_%1"[CR]
	%1	"ON" ----- Screen size is set to Full Screen "OFF" ----- Screen size is not set to Full Screen
	Unacceptable	"Error Code"[CR] ----- When the command is invalid due to condition such as Input source "?"[CR]

9.8.3 CR_TRUE Command

Command	"CR_TRUE"[CR]	
Details	Get if screen size is set to True	
Response	Acceptable	"000_%1"[CR]
	%1	"ON" ----- Screen size is set to True "OFF" ----- Screen size is not set to True
	Unacceptable	"Error Code"[CR] ----- When the command is invalid due to condition such as Input source "?"[CR]

9.8.4 CR_KYSTNMODE Command

Command	"CR_KYSTNMODE"[CR]	
Details	Get Keystone Store Mode setting status	
Response	Acceptable	"000_%a"[CR]
	%a	"STR" ----- Store mode is "Store" "RST" ----- Store mode is "Reset"
	Unacceptable	"?"[CR]

9.9 Lamp Status Read Command

9.9.1 CR_LAMPREPL Command

Command	"CR_LAMPREPL"[CR]	
Details	Get the information of Lamp Replacement time	
Response	Acceptable	"000_%1"[CR]
	%1	"1Y" ----- Over lamp replacement time "1N" ----- Within lamp replacement time "1" means the number of lamps (1 lamp is used→ "1", 2 lamps are used) "Y"/"N" means if it is time to replace lamp or not. Example: "1Y" ----- 1 lamp is used and it is over lamp replacement time
	Unacceptable	"?"[CR]

9.9.2 CR_LAMPMODE Command

Command	"CR_LAMPMODE"[CR]	
Details	Get Lamp Mode setting status	
Response	Acceptable	"000_%1"[CR]
	%1	"NORMAL" ----- Lamp Mode is Normal "ECO" ----- Lamp Mode is Eco "AUTO" ----- Lamp Mode is Auto
	Unacceptable	"?"[CR]

9.9.3 CR_PROJH Command

Command	"CR_PROJH"[CR]	
Details	Get total running time of Projector by hour (h)	
Response	Acceptable	"000_%1"[CR]
	%1	"0000000"~"0099999"
	Unacceptable	"?"[CR]

9.10 Sound Status Read Command

9.10.1 CR_VOLUME Command

Command	"CR_VOLUME"[CR]	
Details	Get Volume value of user control	
Response	Acceptable	"000_%a"[CR]
	%a	"000"~"063"
	Unacceptable	"?"[CR]

9.10.2 CR_MUTE Command

Command	"CR_MUTE"[CR]	
Details	Get sound mute setting status	
Response	Acceptable	"000_%a"[CR]
	%a	"ON" ----- Sound Mute is ON "OFF" ----- Sound Mute is OFF
	Unacceptable	"?"[CR]

9.11 Setting Status Read Command

9.11.1 CR_BBACK Command

Command	"CR_BBACK"(CR)	
Details	Get Blue Back setting status	
Response	Acceptable	"000_%a"[CR]
	%a	"ON" ----- Blue Back is ON "OFF" ----- Blue Back is OFF
	Unacceptable	"?"[CR]

9.11.2 CR_DISP Command

Command	"CR_DISP"[CR]	
Details	Get Display setting status	
Response	Acceptable	"000_%a"[CR]
	%a	"ON" ----- Display is ON "OFF" ----- Display is OFF "CNTDWN-OFF" ----- Countdown is OFF
	Unacceptable	"?"[CR]

9.11.3 CR_LOGO Command

Command	"CR_LOGO"[CR]	
Details	Get Logo setting status	
Response	Acceptable	"000_%1"[CR]
	%1	"OFF" ----- Logo is OFF "DEFAULT" ----- Default Logo is selected "USER" ----- User Logo is selected
	Unacceptable	"?"[CR]

9.11.4 CR_CEIL Command

Command	"CR_CEIL"[CR]	
Details	Get selected Ceiling status	
Response	Acceptable	"000_%1"[CR]
	%1	"ON" ----- ON is selected "OFF" ----- OFF is selected
	Unacceptable	"Error Code"[CR] -

9.11.5 CR_REAR Command

Command	"CR_REAR"[CR]	
Details	Get selected Rear status	
Response	Acceptable	"000_%1"[CR]
	%1	"001" ----- Select Code1 "002" ----- Select Code2
	Unacceptable	"Error Code"[CR] -

9.11.6 CR_RCODE Command

Command	"CR_RCODE"[CR]	
Details	Get selected Remote Control Code status	
Response	Acceptable	"000_%a"[CR]
	%a	"001" ----- Code1 is selected "002" ----- Code2 is selected
	Unacceptable	"?"[CR]

9.11.7 CR_LANG Command

Command	"CR_LANG"[CR]	
Details	Get selected language	
Response	Acceptable	"000_%a"[CR]
	%a	"ENG" ----- English is selected "DEU" ----- German is selected "FRA" ----- French is selected "ITA" ----- Italian is selected "ESP" ----- Spanish is selected "POR" ----- Portuguese is selected "NED" ----- Dutch is selected "SVE" ----- Swedish is selected "JPN" ----- Japanese is selected "CHI" ----- Chinese is selected "KOR" ----- Korean is selected "RUS" ----- Russian is selected "FIN" ----- Finnish is selected "POL" ----- Polish is selected "HUN" ----- Hungarian is selected "ROM" ----- Romanian is selected
	Unacceptable	"?"[CR]

9.11.8 CR_ZOOM Command

Command	"CR_ZOOM"[CR]	
Details	Get Zoom store mode setting status	
Response	Acceptable	"000_%a"[CR]
	%a	"RST" ----- "Reset" is selected "STR1" ----- "Store1" is selected "STR2" ----- "Store 2" is selected
	Unacceptable	"?"[CR]

9.11.9 CR_INPUTSEARCH Command

Command	"CR_INPUTSEARCH"[CR]	
Details	Get Input search setting status	
Response	Acceptable	"000_%a"[CR]
	%a	"OFF" ----- Input search is OFF "ON1" ----- Input search is set to On1 "ON2" ----- Input search is set to On2
	Unacceptable	"?"[CR]

9.11.10 CR_ON-STA Command

Command	"CR_ON-STA"[CR]	
Details	Get Power ON Start setting status	
Response	Acceptable	"000_%a"[CR]
	%a	"ON" ----- Power ON Start is ON "OFF" ----- Power ON Start is OFF
	Unacceptable	"?"[CR]

9.11.11 CR_P-MANE Command

Command	"CR_P-MANE"[CR]	
Details	Get Power management setting status	
Response	Acceptable	"000_%a"[CR]
	%a	"OFF" ----- Power Management is canceled "READY" ----- Power Management is Ready "SHUTDOWN" ----- Power Management is set to Shut Down mode
	Unacceptable	"?"[CR]

9.11.12 CR_P – MANETIME Command

Command	"CR_P-MANETIME"[CR]	
Details	Get time setting to start Power Management	
Response	Acceptable	"000_%a"[CR]
	%a	"001"~"030" -----1 minute to 30 minutes
	Unacceptable	"?"[CR]

9.11.13 CR_FANSPEED Command

Command	"CR_FANSPEED"[CR]	
Details	Get selected Fan Control Speed	
Response	Acceptable	"000_%a"[CR]
	%a	"MAX" ----- Fan Control Speed is Max "NOR" ----- Fan Control Speed is Normal
	Unacceptable	"?"[CR]

9.11.14 CR_TERMINAL Command

Command	"CR_TERMINAL"(CR)	
Details	Get Terminal setting status	
Response	Acceptable	"000_%a"[CR]
	%a	"COMPUTER" ----- Computer Input Mode "MONITOR" ----- Monitor Out Mode
	Unacceptable	"?"[CR]

9.11.15 CR_FANMODE Command

Command	"CR_FANMODE"[CR]	
Details	Get selected Fan mode	
Response	Acceptable	"000_%a"[CR]
	%a	"L1" ----- Fan mode L1 "L2" ----- Fan mode L2
	Unacceptable	"?"[CR]

9.11.16 CR_UNIFORMITY Command

Command	"CR_UNIFORMITY"[CR]	
Details	Get selected Uniformity mode	
Response	Acceptable	"000_%a"[CR]
	%a	"L1" ----- Fan mode L1 "L2" ----- Fan mode L2
	Unacceptable	"?"[CR]

9.11.17 CR_FILH Command

Command	"CR_FILH"[CR]	
Details	Get selected Filter use time mode	
Response	Acceptable	"000_%1"[CR]
	%1	"00000"~"99999" ----- 0 hour to 99999 hours
	Unacceptable	"?"[CR]

9.11.18 CR_FILREPL Command

Command	"CR_FILREPL"[CR]	
Details	Get the information of Filter replacement time	
Response	Acceptable	"000_%1"[CR]
	%1	"1Y" ----- Over filter replacement time "1N" ----- Within filter replacement time
	Unacceptable	"Error Code"[CR]

9.11.19 CR_FILTIMER Command

Command	"CR_FILTIMER" [CR]	
Details	Get setting time of Filter warning timer	
Response	Acceptable	"000_%1"[CR]
	%1	"100" ----- 100 hours "200" ----- 200 hours "300" ----- 300 hours "OFF" ----- No OSD display
	Unacceptable	"Error Code"[CR]

9.12 Other Status Read Command

9.12.1 CR_SIGNAL Command

Command	"CR_SIGNAL"(CR)	
Details	Get Signal status if there is signal or not	
Response	Acceptable	"000_%a"[CR]
	%a	"ON" ----- There is signal "OFF" ----- There is no signal
	Unacceptable	"?"[CR]

9.12.2 CR_VMUTE Command

Command	"CR_VMUTE"[CR]	
Details	Get No Show setting status	
Response	Acceptable	"000_%a"[CR]
	%a	"ON" ----- No Show is ON, Display User Logo (My picture) "OFF" ----- No Show is OFF
	Unacceptable	"?"[CR]

9.12.3 CR_FREEZE Command

Command	"CR_FREEZE"(CR)	
Details	Get Freeze setting status	
Response	Acceptable	"000_%a"[CR]
	%a	"ON" ----- Freeze is ON "OFF" ----- Freeze is OFF
	Unacceptable	"?"[CR]

9.12.4 CR_PTIMER Command

Command	"CR_PTIMER"[CR]	
Details	Get the operating status of Presentation Timer	
Response	Acceptable	"000_%a"[CR]
	%a	"ON" ----- Presentation timer is in operation "STOP" ----- Presentation timer is paused "OFF" ----- Presentation timer is not operated
	Unacceptable	"?"[CR]

9.12.5 CR_TEMPWARN Command

Command	"CR_TEMPWARN"[CR]	
Details	Get the temperature inside a projector if it is abnormal temperature or close to abnormal temperature It is possible to get the status all at once with some sensors installed.	
Response	Acceptable	"000_%a_%b_%c"[CR]

		<p>%a ----- Sensor 1 status %b----- Sensor 2 status %c----- Sensor 3 status</p> <p>“W” ---- Approach or reach abnormal temperature (dangerous temperature) “S” ---- Far from abnormal temperature (safe temperature) “N” ---- Sensor detects no abnormal temperature</p> <p>[Example] “S_W_S”[CR] means Sensor 1 detects safe temperature, Sensor 2 detects abnormal temperature and Sensor 3 detects safe temperature Note) When the temperature difference between Sensor 1 and 3 reaches specific value, it is considered as temperature abnormality by the projector model. In this case, the 3rd data means if the temperature difference between Sensor 1 and 3 is dangerous state or not. The 3rd data means temperature abnormality due to Sensor 3 When abnormal temperature is not detected by sensor, “N” (No connection with temperature abnormality) is returned.</p>
	Unacceptable	“?”[CR]

9.12.6 CR_TEMPFAIL Command

Command	"CR_TEMPFAIL"[CR]	
Details	Get the temperature inside a projector when abnormal temperature occurs. It is possible to get the temperatures all at once with some sensors installed.	
Response	Acceptable	“000_%a_%b_%c”[CR]
	%a %b %c	<p>%a ----- Sensor 1 temp. (External temp.) %b ----- Sensor 2 temp. (Internal temp.1) %c ----- Sensor 3 temp. (Internal temp.2)</p> <p>[Example] “_31.5F”[CR] “_” indicates a space. When the temperature sinks to -, the first character is “-” like “-05.5F”[CR] The last character means the sensor's status if it reaches abnormal temperature</p> <p>Exceeding critical temp. ----- “F” Temp. is safe ----- “S” Sensor detects no critical temp.----- “N”</p> <p>The example shows that sensor 1 indicates 31.5 degrees and the temperature is abnormal. When the temperature is safe, all data are represented as “□000S”. When the projector is reset, “□000S” is set, and every time abnormal temperature occurs, it renews the data and returns it. In short, it only returns the renewed data of the latest abnormal temperature and the previous data is deleted.</p>
	Unacceptable	“?”[CR]